

Kiki Weekender

The Kiki is a weekend wonder bag- your go to for impromptu getaways or meticulously planned escapes. A practical statement piece with room for all your essentials and then some.

PATTERN NO. **203**

FEATURES

- Wide shoulder straps
- Exposed present fold
- Spacious interior

DIFFICULTY

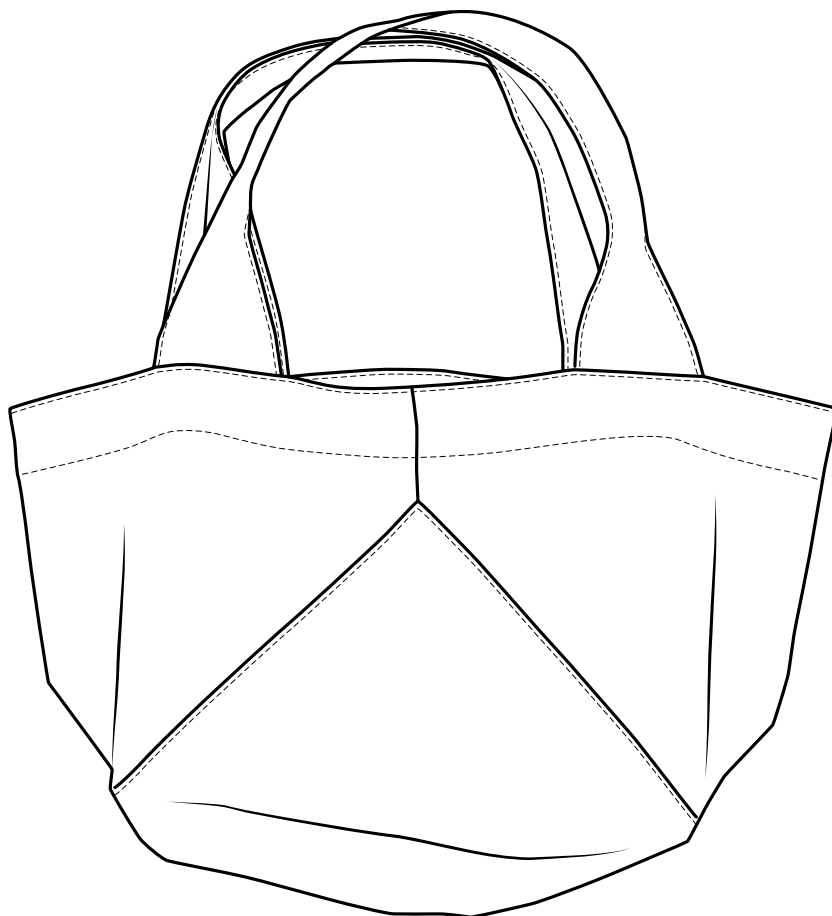

Choosing the Right Size

The Kiki Weekender is a single size pattern.

See Pattern Set Up on page 4 for instructions to lengthen or shorten the bag height or straps.

Finished Bag Measurements

	OS
STRAP	27"
	68.6 cm
LENGTH X WIDTH X HEIGHT	16" x 10" x 12"
	40.6 x 25.4 x 30.5 cm

Supplies

FABRIC RECOMMENDATIONS

For sturdiest results choose heavier weight cotton/linen/canvas or try your hand at an interior fabric or leather. However, we believe you can make everything out of anything, feel free to contact us for advice if you're feeling adventurous.

NOTIONS

- Needles suggested for fabric choice
- All-purpose thread in matching colors
- Heavyweight topstitching thread (optional)

TOOLS

MARKING TOOL

EDGESTITCH FOOT (1/8") (OPTIONAL)

Cutting Measurements

	OS
STRAP	28" x 8"
	71.1 x 20.3 cm
BAG	41" x 27"
	104.1 x 68.6 cm
FACING	27" x 3"
	68.6 x 7.6 cm

* Measurements provided if not printing pattern file.

Home Printing Info

See instructions on our website [here](#).

PRINTING LAYOUT

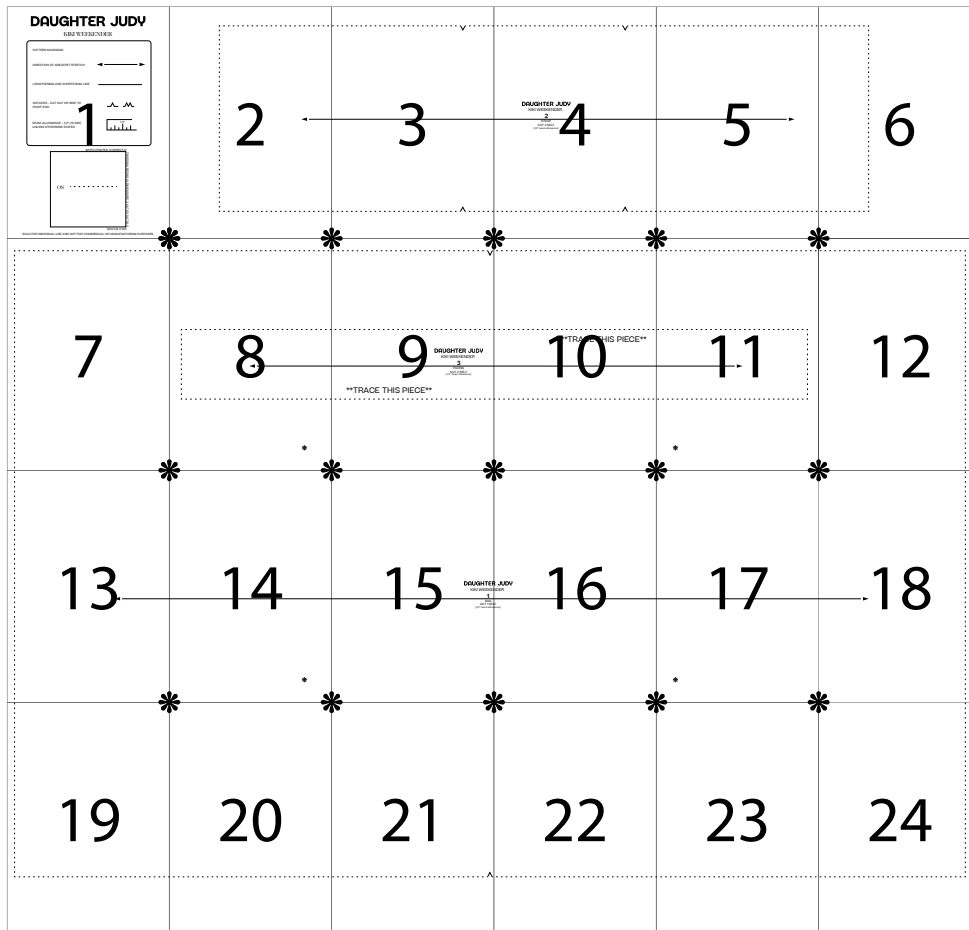

PAGES PER VIEW

1 - 24

Pieces, in order as they appear

- 1 Strap—self x2
- 2 Bag—self x1
- 3 Facing—self x2

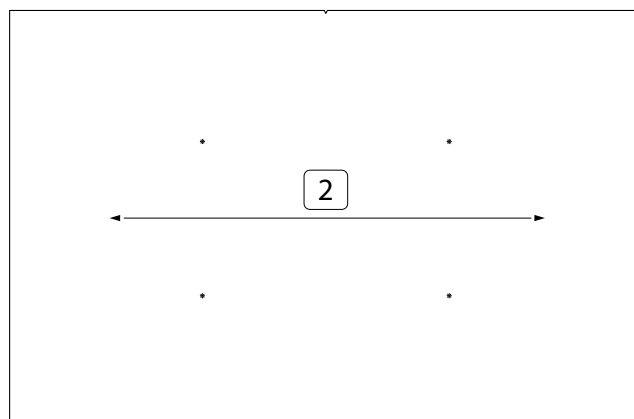

Pattern Set Up

READY

Select pattern pieces for the view you plan to make from pieces table. Make any necessary adjustments before cutting.

To Lengthen/Shorten—Find the shorter edges of the bag pattern or one end of strap pattern. To lengthen, add desired amount to the end of the pattern pieces. To shorten, remove desired amount from the end of the pattern pieces

CUT

Prepare fabric by preshrinking if necessary, straightening grain or uneven ends. Place fabric right side up unless specifically indicated on layout. Before removing pattern from fabric, transfer all construction lines and symbols to fabric with marking tool of your choice.

SEW

Follow sewing instruction guide to assemble your bag. Be sure to press as you sew and finish all edges as desired. You can finish seam edges in any way you prefer; overlock, binding, pinking, etc. to prevent fraying.

Glossary

COVERSTITCH

Similar to a chainstitch with 2 rows of lockstitching and looper threads that weave across the 2 rows. The preferred finish for stretch openings because it is the strongest.

EDGESTITCH

Standard stitch between 8–12 SPI (stitches per inch) used for external construction as a decorative detail, giving the garment a higher quality look. Or internal construction to help pull seams down and keep them flat. Usually between $\frac{1}{16}$ " and $\frac{1}{8}$ " from edge or seam.

FINISH

Application of stitches, binding, pinking etc. to an edge to prevent fraying and add to the longevity of a garment.

MOCKSAFETY

A combination of a lockstitch and an overlock that are looped together.

OVERLOCK

Three thread (typically) stitch that loops over the edge of a single or double layer of fabric for cleaner finishing on internal construction.

PINKED EDGE

A zig zagged edge, typically done by scissors, that prevents fraying because fabric is being cut on the bias.

Shading Guide: Sewing



FABRIC RIGHT SIDE



FABRIC WRONG SIDE



STRAIGHT GRAIN

Included seam allowance is 1/2" (12mm) unless otherwise noted in nomenclature on pattern piece.

STRAPS



1
With right sides together stitch along long edges from end to end of STRAP 1.

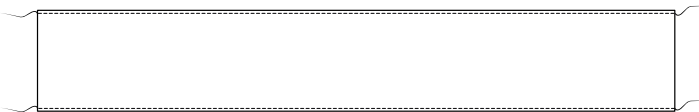

2
Turn straps to right side out, press and **edgestitch** 1/8" (3mm) along both long edges.

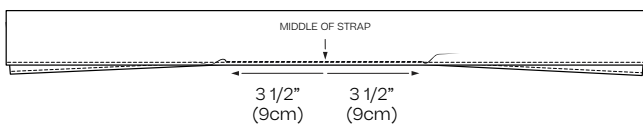

3
Bring long edges together by folding strap in half. Stitch along previous stitching from notch to notch if using printed pattern. If not find the middle of the strap length and mark 3 1/2" (9cm) in both directions, closing together 7" (18cm) total.

BAG

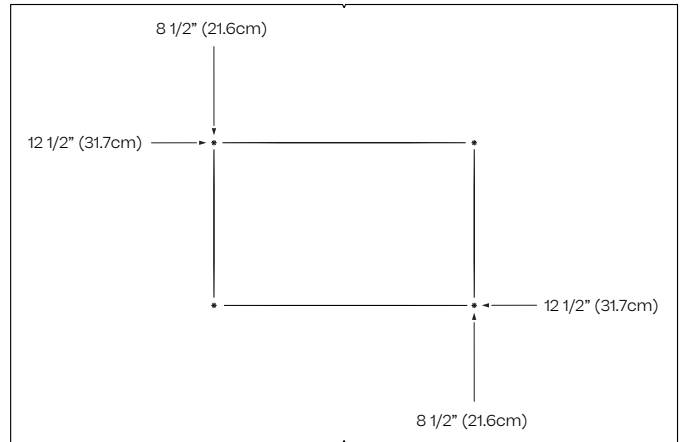

4
Pre-press between dots to create base of BAG
2. Follow dots on pattern piece or use the above measurements to find these positions. This will help in creating the present fold.

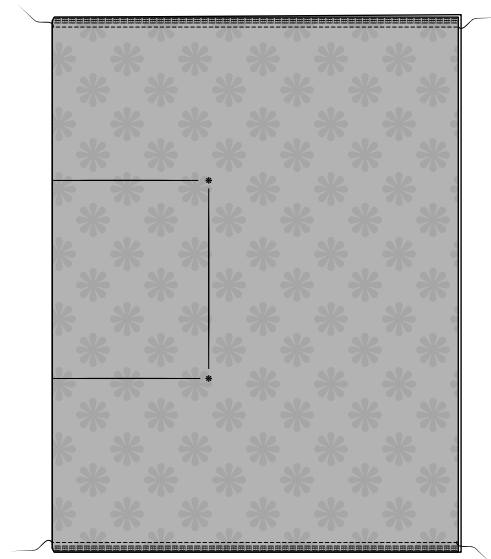

5
Bring shorter ends of BAG 2 right sides together and stitch from short end edge to fold, backtack well and **finish** both edges. Press seam allowance to one side.

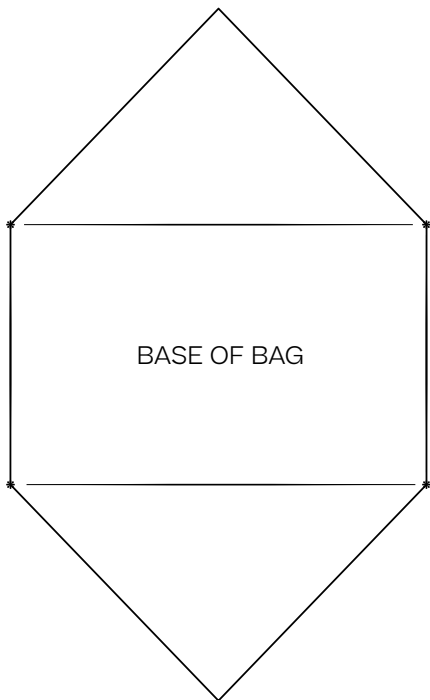

6
Turn BAG 2 to right side out and press present fold edges on each side guided by dots at base. The point will be the fold edge of the previous stitching.

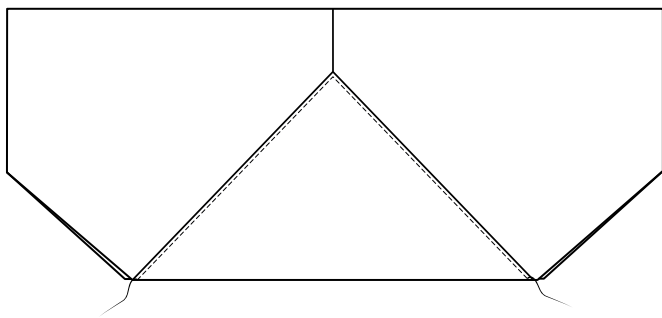

7
Bring the points up to meet the vertical seams where they naturally want to fall using the pre-pressed base edges. **Edgestitch** 1/8" (3mm) along present fold from corner to corner around point as far towards lower corners as you can.

FACING + FINISHING



8
With right sides together join short ends of FACING 3 forming a ring. Press seams open. Press one edge of ring under along 1/2" (1.2cm) seam allowance, wrong sides together.

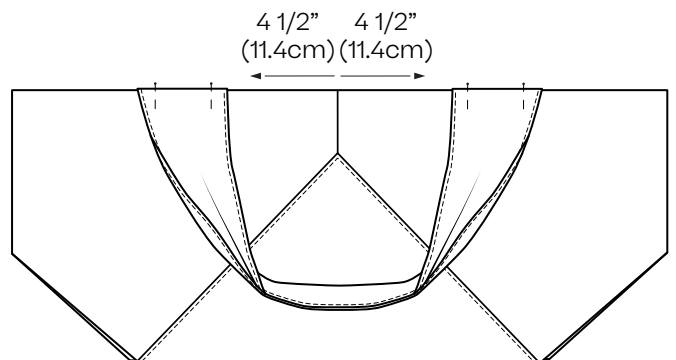

9
Mark 4 1/2" (11.4cm) in both directions from vertical seam on BAG 2. Pin straps in place on each side with stitching sides facing you as you pin.

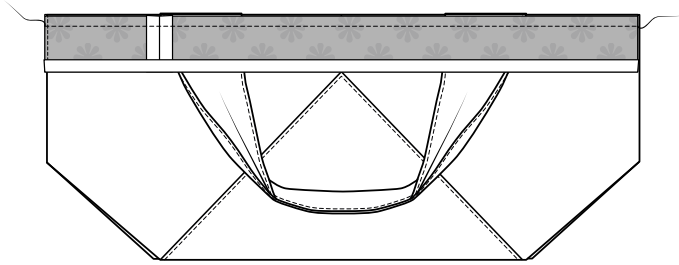

10

Join unpressed edge of FACING 3 ring to bag opening, sandwiching straps between the two.

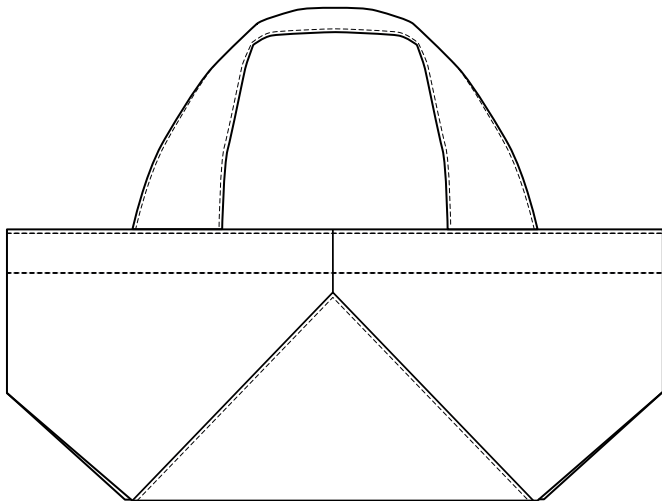

11

Turn facing 3 to inside of bag bringing wrong sides together and press in place. **Edgestitch** 1/8" (3mm) around bag opening and lower edge of facing.