

Honey by Fibre ⚡ood



Honey by Fibre ⚡ood



0 - 26

Big sleeves have secured their leading role on the fashion scene, but look out... because the age of statement collars has begun!

The Honey top is a dazzling example of this trend.

A romantic ruffled trim graces the full length of the collar. Don't want to overdo the ruffles? This brilliant boxy blouse has charm in spades. And that stays true even with a back-to-basics look, with just a simple collar band and a button placket. Honey drapes beautifully with a subtle A-line cut created by the ruffles at the back. The sleeves are finished with ruffles at the bottom, trim and ties. Before you start cutting, be sure to carefully check the top's pattern measurements first to select the length you want.

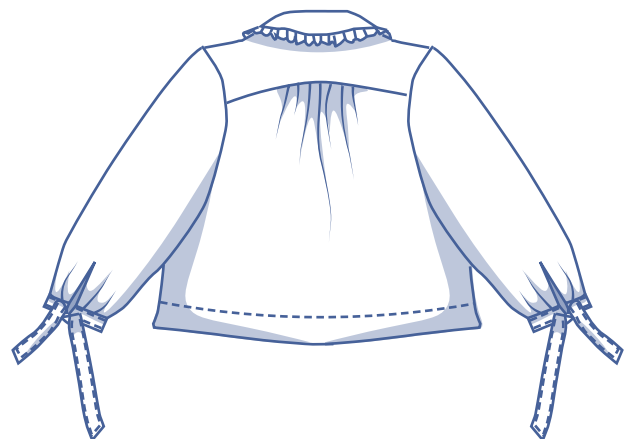
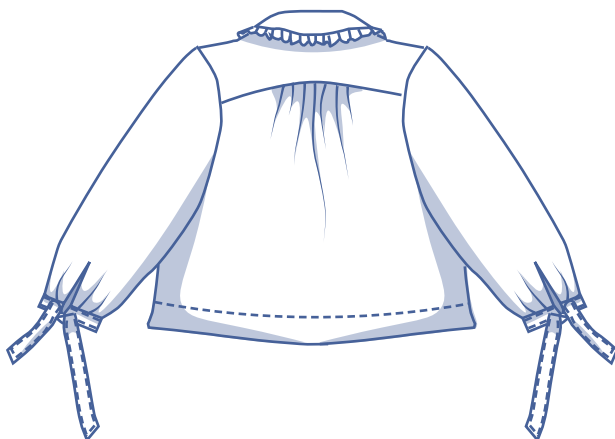
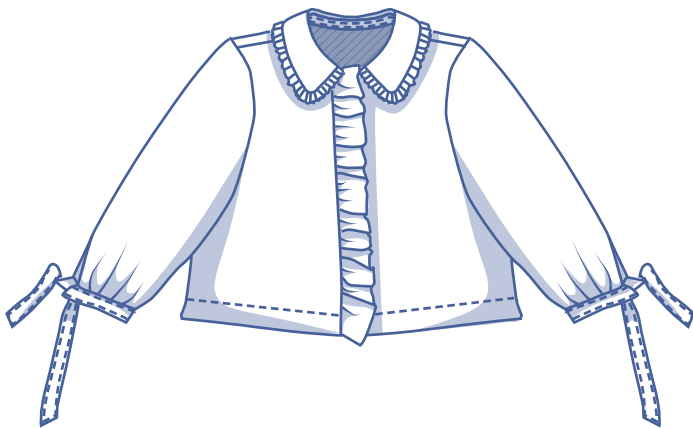

size chart (in inches)

size	0	2	4	6	8	10	12	14	16	18	20	22	24	26
body height	5'25"	5'38"	5'45"	5'48"	5'51"	5'54"	5'58"	5'61"	5'64"	5'64"	5'64"	5'64"	5'64"	5'64"
B (bust)	29.9	31.5	33.1	34.6	36.2	37.8	39.4	40.9	43.3	45.7	48.1	50.4	52.8	55.1
H (hips)	33.9	35.4	37	38.2	39.4	40.6	41.7	42.9	45.3	47.2	49.2	51.2	53.1	55.1

Choose your size based on your bust measurement. If your hip measurements are wider than those in the size chart, check the hem circumference in the chart below to see if there's enough room or whether the pattern needs to be altered. It's easy to do. Simply trace the line of the one size instead of the other.

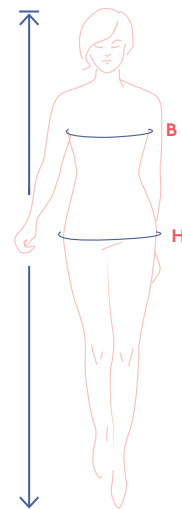

pattern measurements (in inches)

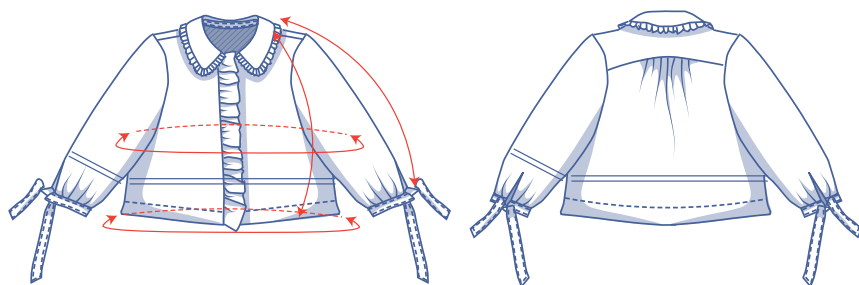

— shorten or lengthen the pattern here

This chart's measurements are the pattern measurements based on the fabric type and serve as a reference. Ease has been added to the width (in addition to the exact body measurements) for a more comfortable fit. Honey is designed to have a loose cut. Depending on the preferred cut, you could decide to go a size smaller or larger than the recommended size.

IMPORTANT! This is a boxy top. So compare carefully the stated lengths with the length you prefer.

size	0	2	4	6	8	10	12	14	16	18	20	22	24	26
length	20.5	20.6	20.7	20.8	20.9	21	21.1	21.2	21.4	21.6	21.7	21.9	22.1	22.3
sleeve length*	24.4	24.5	24.6	24.7	24.8	24.9	25.1	25.2	25.3	25.5	25.7	25.8	26	26.1
bust	33.8	35.4	37	38.6	40.2	41.8	43.3	44.9	47.3	49.7	52.1	54.5	56.8	59.2
hem circumference	37.2	38.9	40.6	41.9	43.2	44.5	45.8	47.1	49.2	51.3	53.4	55.5	57.6	59.7

* Including the shoulder length and cuff.

Compare the stated lengths to the measured or desired lengths. Lengthen or shorten the top and/or the sleeves by cutting the pattern pieces at the indicated double lines. Then either increase the distance between the cut pieces by the desired amount (to lengthen), or overlap the pieces (to shorten). Make sure that the CF and CB lines and the side seams are always straight.



IMPORTANT

Adjust the amount of fabric to be used based on these alterations.

supplies



- Thread
- Iron-on interfacing: max. 0.8 yd
- Buttons (Ø 3/8"): 5
- Snap (Ø 1/6"): 1
- Fabric: see table

fabric		0	2	4	6	8	10	12	14	16	18	20	22	24	26
fabric width 43"	yd	2 3/4	2 3/4	3	3	3	3	3	3	3	3	3	3	3 1/4	3 1/4
fabric width 55"	yd	2 1/4	2 1/4	2 1/4	2 1/2	2 1/2	2 1/2	2 3/4	2 3/4	2 3/4	2 3/4	2 3/4	2 3/4	2 3/4	3

The corresponding fabric layout can be found on page 6 of these sewing instructions.

fabric advice



Honey looks fabulous in all kinds of fabrics – thank goodness! Woven fabrics work best though due to the delicate details. Poplin, Tencel, linen, crepe, wool and wool blends, flannel, etc. are good options. This pattern is flexible and looks good in both solids and prints.

Proud to be #Sewista

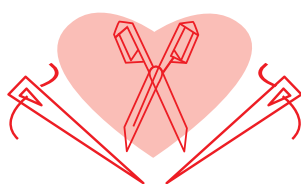

pattern pieces & seam allowances (in inches)

To sew the garment as described in the instructions, draw the illustrated seam allowances around the paper pattern pieces before cutting them out. If you are using a PDF pattern, the pattern can be printed with or without seam allowance.

To find out more, watch the [video](#).

1. left front: 1x
2. right front: 1x
3. yoke: 2x on fabric fold
4. back: 1x on fabric fold
5. sleeve: 2x
6. cuff (+ ties): 2x on fabric fold
7. collar: 2x on fabric fold
8. collar band: 2x on fabric fold
9. buttonhole placket RF: 1x
10. front ruffle: 1x
11. collar ruffle: 1x on fabric fold
12. sleeve binding: 2x

KEEP IN MIND!

If you go for a version without the front ruffle then you use 2x pattern piece 1 instead of 1x pattern piece 1 + 1 x pattern piece 2. You don't need pattern pieces 9 and 10 for this version.

IMPORTANT

The pieces highlighted in light yellow have iron-on interfacing attached to the wrong side.

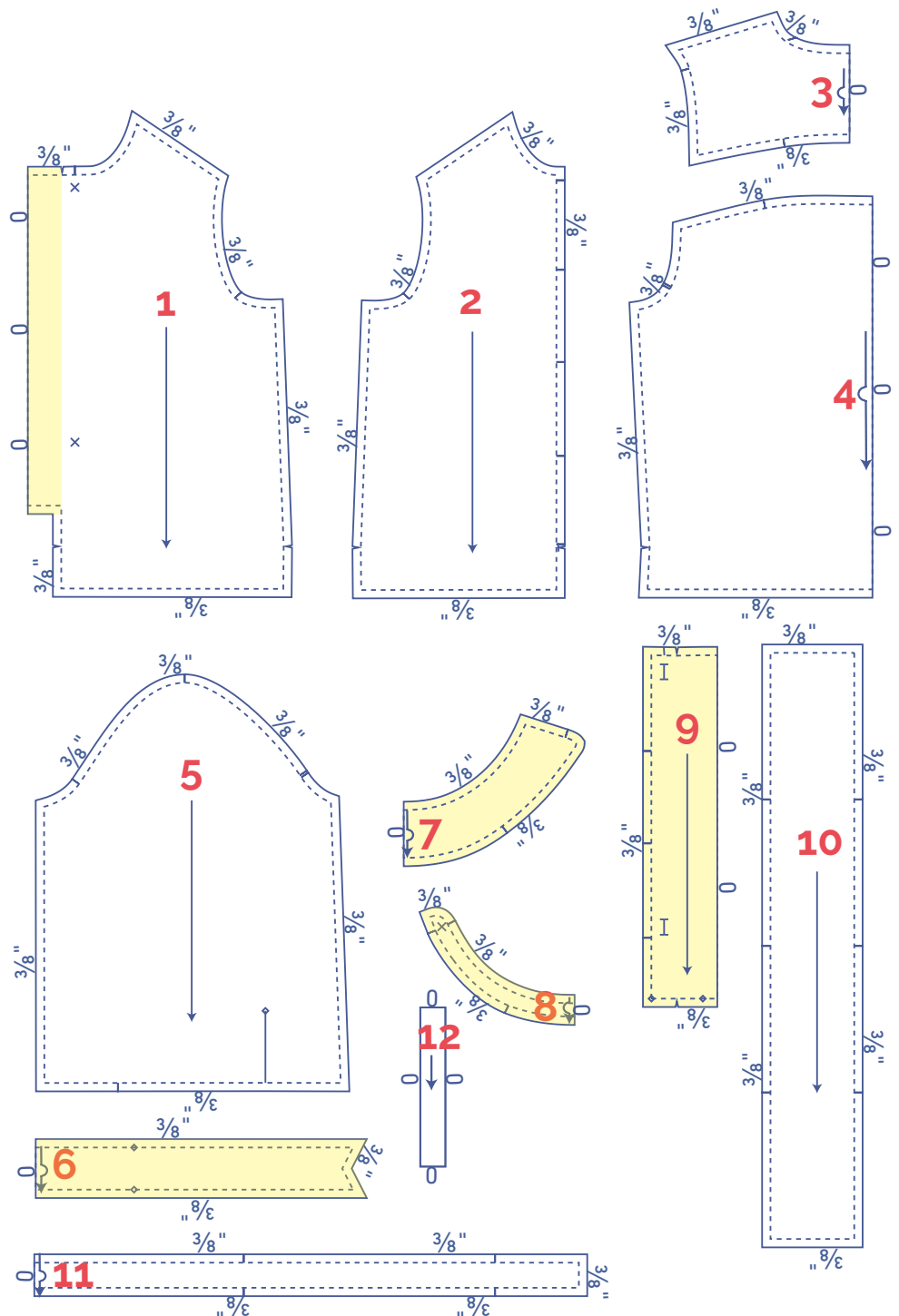

	material type
	fabric
	iron-on interfacing

fabric layout – solid fabrics
fabric width 43"

0 - 22

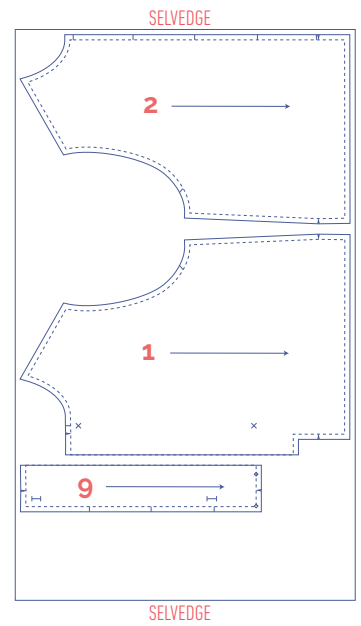
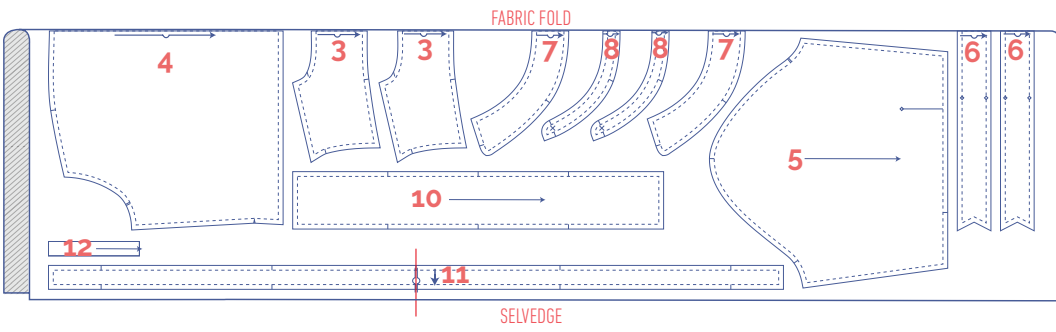

IMPORTANT

You only need pattern pieces 10 and 11 once.

24 - 26

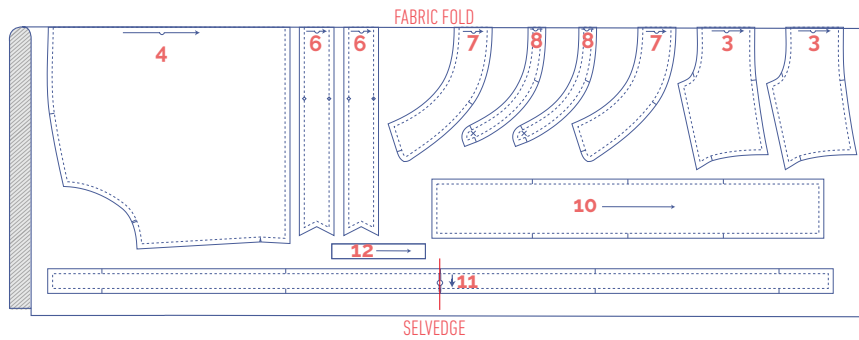

IMPORTANT

You only need pattern pieces 10 and 11 once.

+

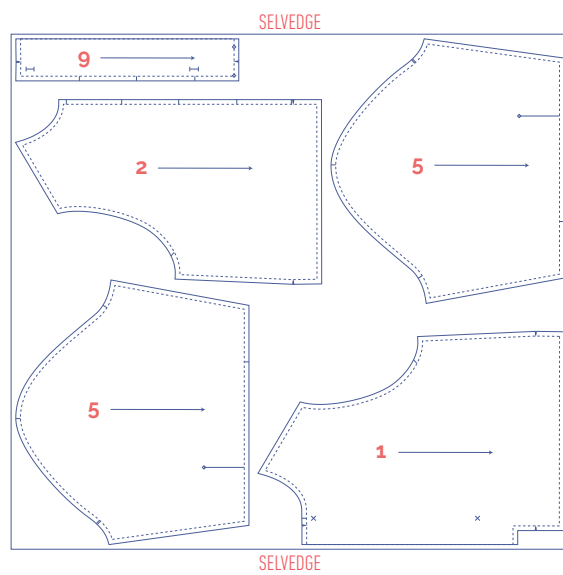

fabric layout – solid fabrics fabric width 55"

0 - 10

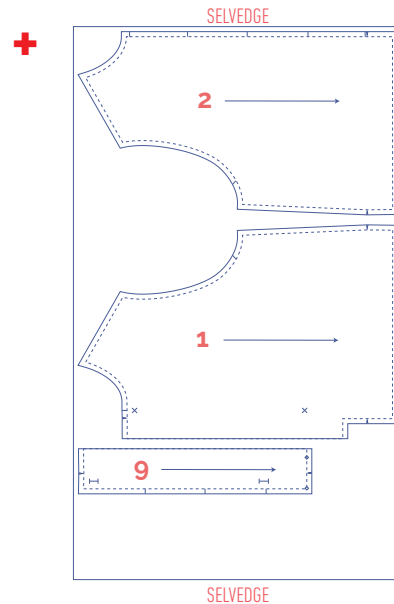
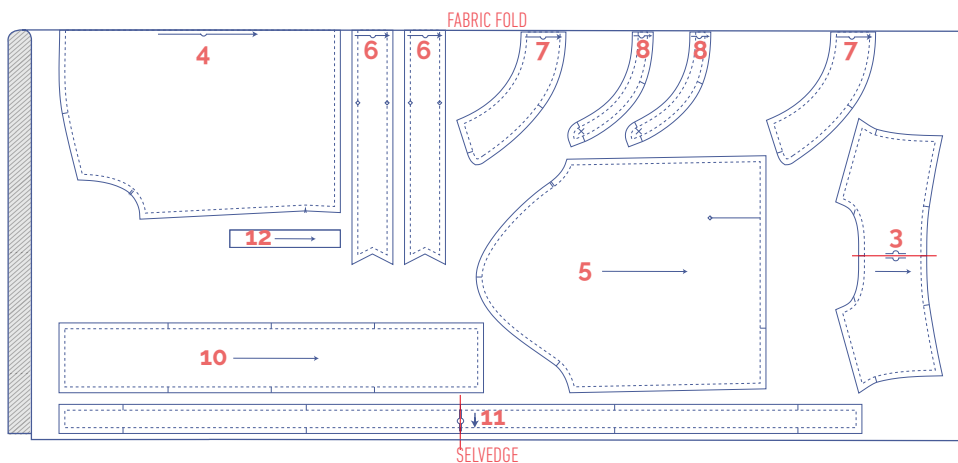

IMPORTANT

You only need pattern pieces 10 and 11 once.

12 - 26

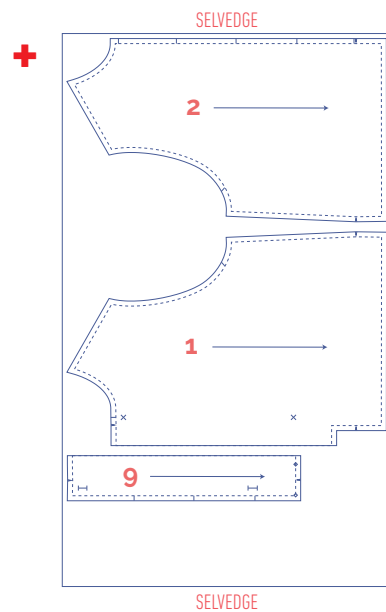
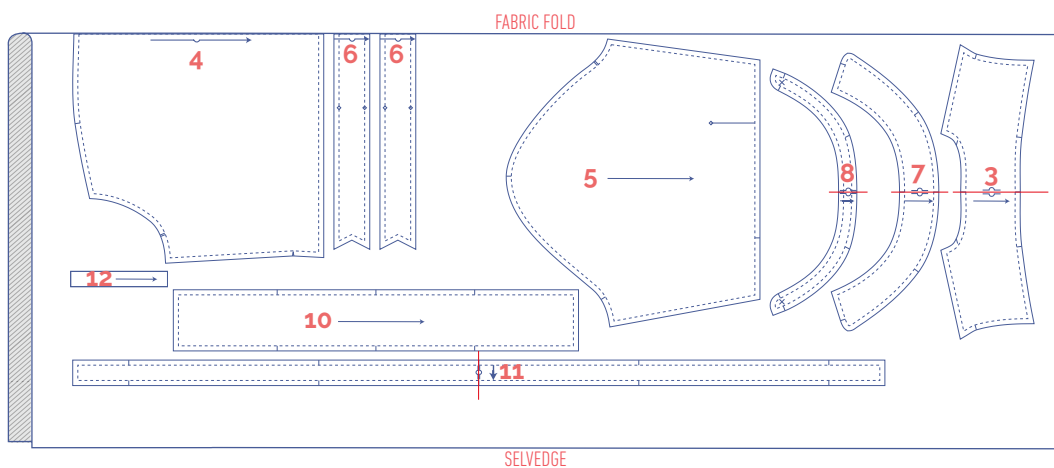

IMPORTANT

You only need pattern pieces 10 and 11 once.

marking pattern pieces

	notch the pattern paper and fabric at the following points
	single notch
	double notch
∇	V notch

	mark the following points using marking thread
	centre point
	snap/button
	buttonhole

sewing instructions



The method used to finish the seams depends on the fabric used. The pieces are always sewn together with the right sides of the fabric facing, unless stated otherwise.

F front

B back

RF right front 

LF left front 

CF centre front

CB centre back

 right side

 iron-on interfacing

KEEP IN MIND!

If you go for a version without a front ruffle then you use 2x patternpiece 1 instead of 1x patternpiece 1 + 1 x patternpiece 2. Finish both patternpieces as the LFP.

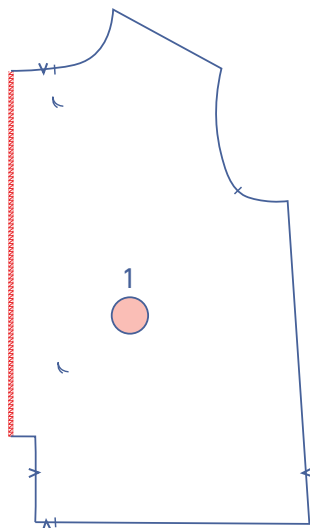

1

Finish the CB line of the LF (1) with overlock stitching.

Start by pressing the hem allowance of the LF and RF (2) 3/8" over.

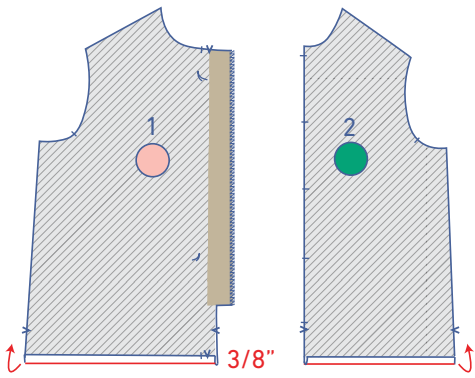

Now, press again, this time from the V notches (2") to create fold lines. Open back out.

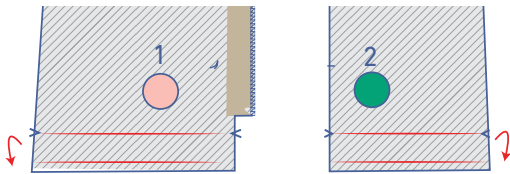
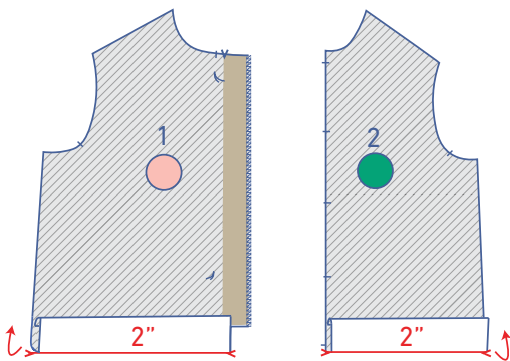

Fold the hem allowance of the LF over at the V notches towards the right side. Sew the short section of the CF (indicated by the V notch) up to the pressed fold line.

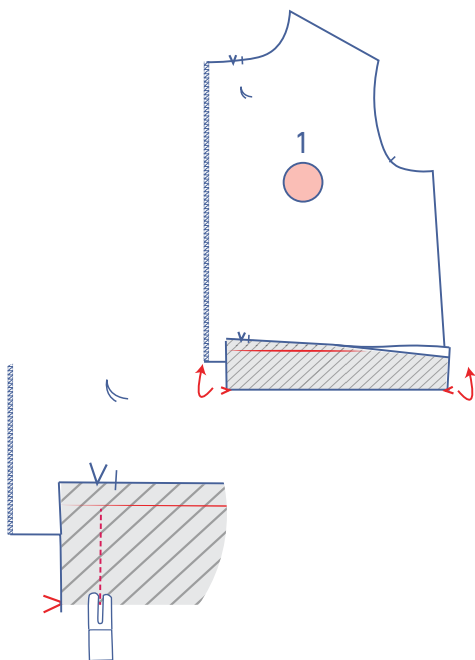

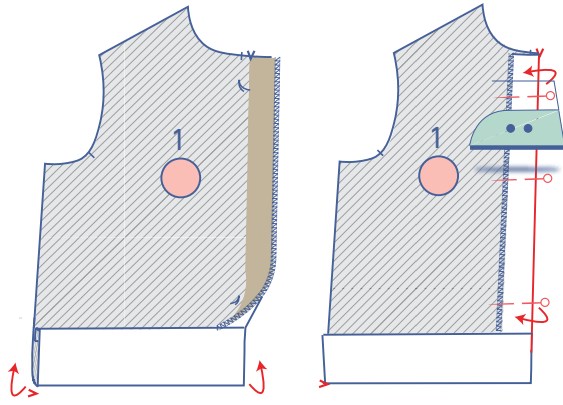

Turn the hem allowance over onto the wrong side. Press the button placket over at the V notches. Pin temporarily into place.

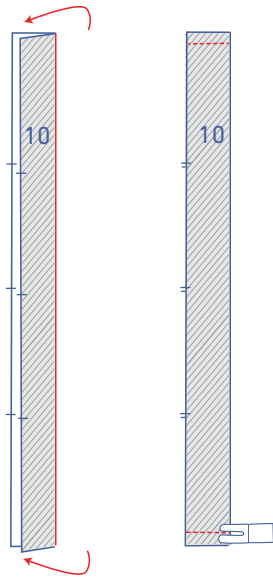

Fold the strip for the flounce (10) in half lengthwise with the right sides of the fabric facing. Stitch the short ends at the top and bottom.

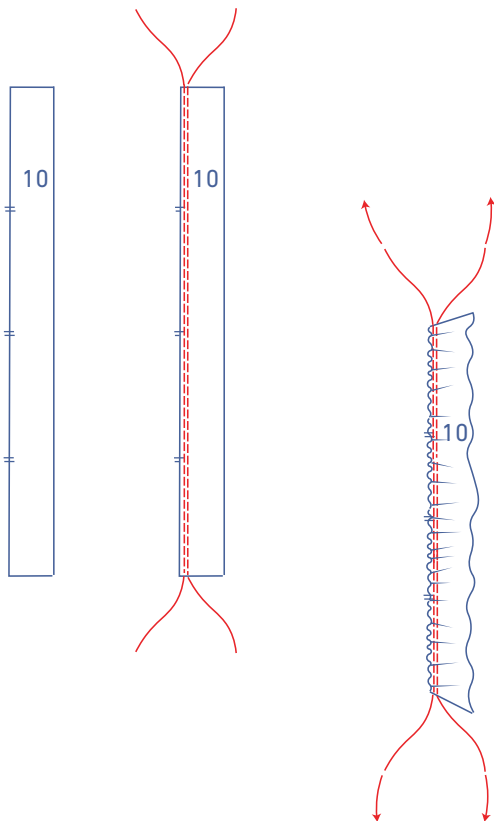

Turn the right way out. Use a long stitch at a low thread tension to sew two parallel rows of stitching down the full length of the raw edges. Leave the thread tails long at the beginning and at the end.

Carefully tug the ends of the gathering threads to create ruffles in the fabric.

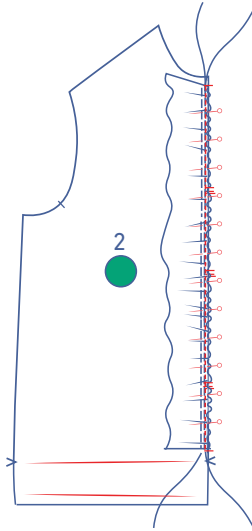

Pin the finished top and bottom of the front ruffle to the RF, matching the notches at the top and the bottom. Distribute the ruffles until the notches in the RF and the flounce match. Sew the flounce to the RF close to the edge within the 3/8" seam allowance.



Finish the unnotched edge of the buttonhole placket RF (9) with overlock stitching.

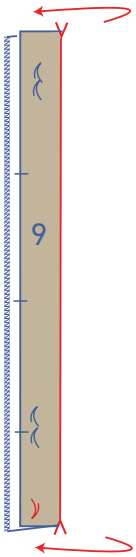

Fold the buttonhole placket RF in half lengthwise at the V notches with the right sides of the fabric touching. Make sure that the marking threads are matching.

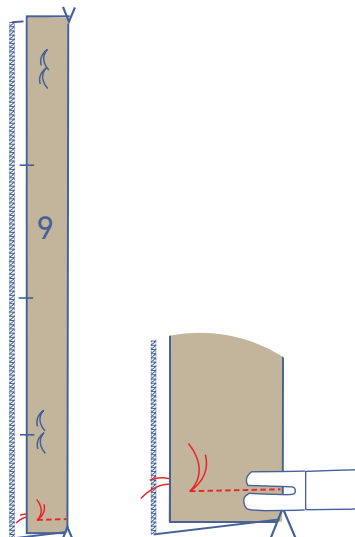

Stitch the bottom right up to the marking threads.

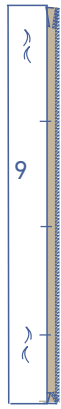

Turn the right way out.

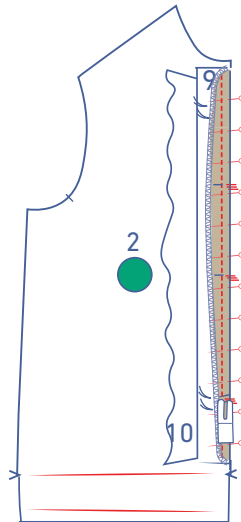

Pin and sew the notched edge of the buttonhole placket to the CF line on the RF + front ruffle (5) with the notches matching. Fold back the top section of the buttonhole placket to the side to do this so that you only stitch the bottom layer.

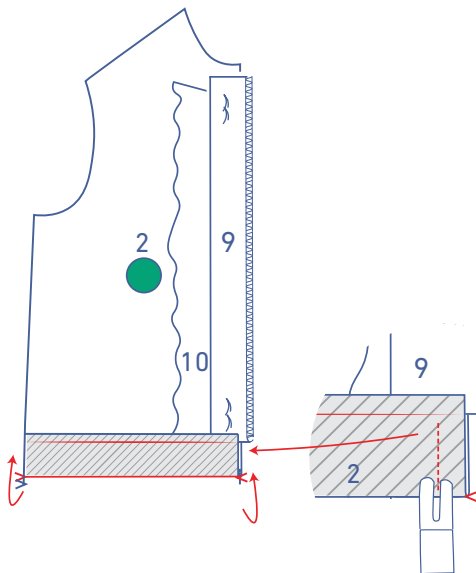

Fold the hem allowance over at the V notches towards the right side and sew the short section of the CF up to the pressed fold line.

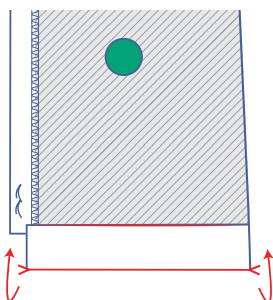

Turn the hem allowance over onto the wrong side and tuck under the raw edge.

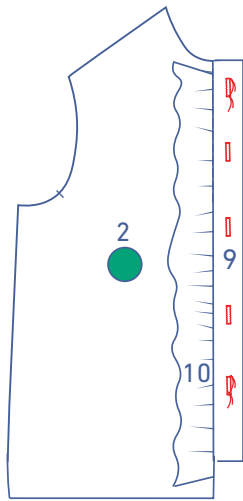

Fold the buttonhole placket over and make vertical buttonholes where indicated. The top and bottom buttonholes have been marked on the pattern. Divide the distance between these evenly to determine the locations of the remaining buttonholes.

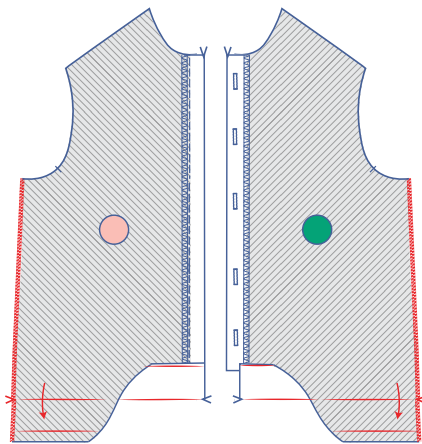

Finish the side seams of the LF and RF with overlock stitching.

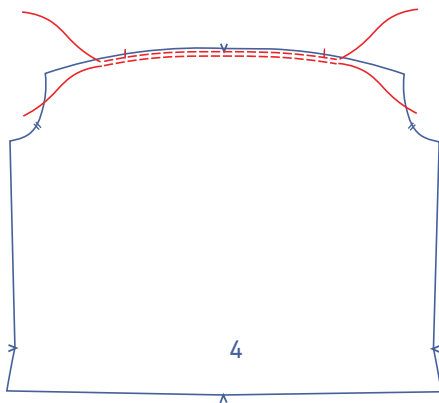

2

Sew 2 parallel rows of stitching at the top of the back (4), using a long stitch length at a low thread tension. Sew just past the notches on either side. Leave long thread tails at the beginning and the end.

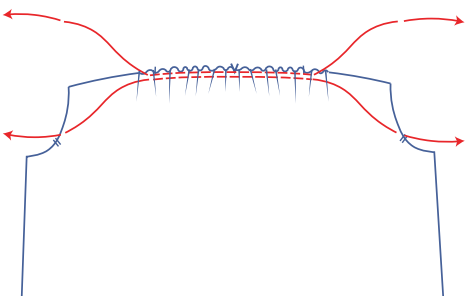

Carefully tug the ends of the gathering threads to create ruffles in the fabric.

Distribute the ruffles so that the notches in the back and the yoke (3) are matching.

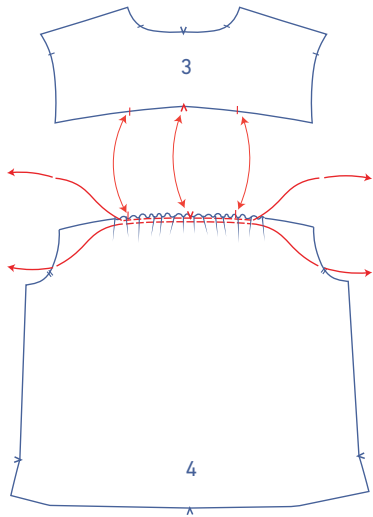

Place the bottom ends of both yoke pieces (3) together with the right sides touching.

Slide them over the back with the right side of the back facing up. The yoke on top is marked with a green star, and the yoke that will later end up on the inside of the top is marked with a red star.

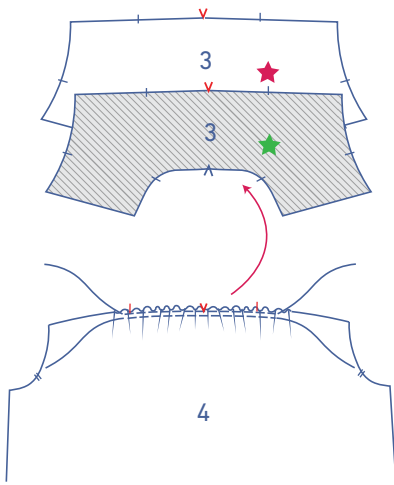

Pin and sew these three layers together with the notches matching.

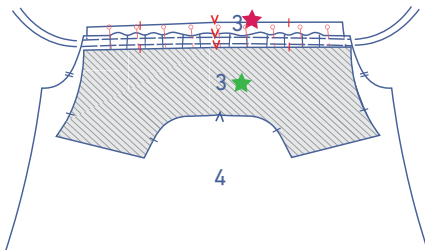

Fold the yoke pieces up.

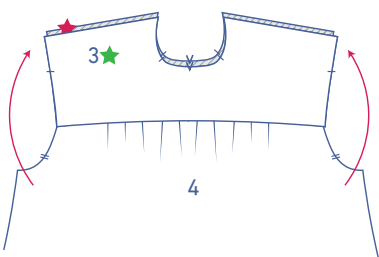

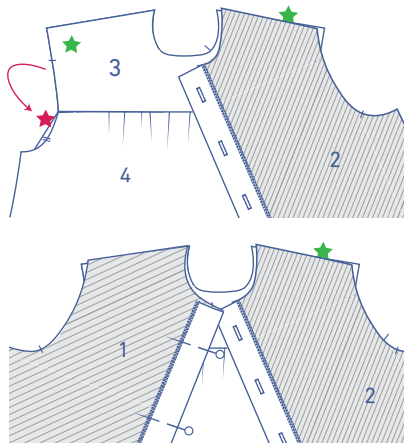

Place the shoulder seams of the front and of the yoke marked with the green star on top of each other with the right sides facing.

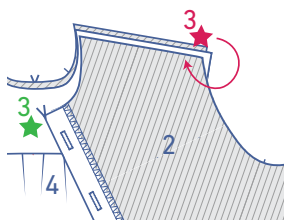

Now, take the shoulder seam of the yoke marked with the red star. Turn this over towards the front, with the right side facing the wrong side of the front.

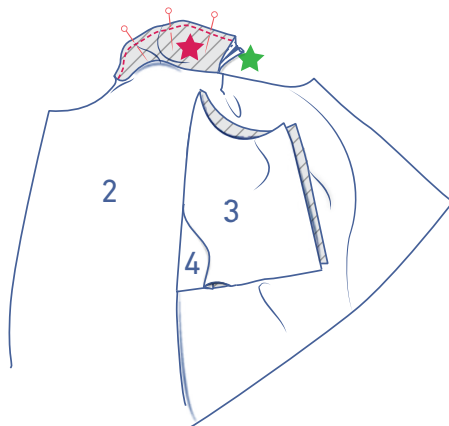

Match the 3 raw edges (red-star yoke piece + green-star yoke piece + front) and sew into place. Turn the right way out. The shoulder seam of the front should be neatly positioned between the yoke pieces.

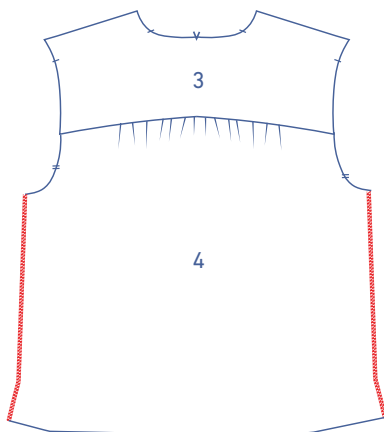

Finish the side seams of the back with overlock stitching.

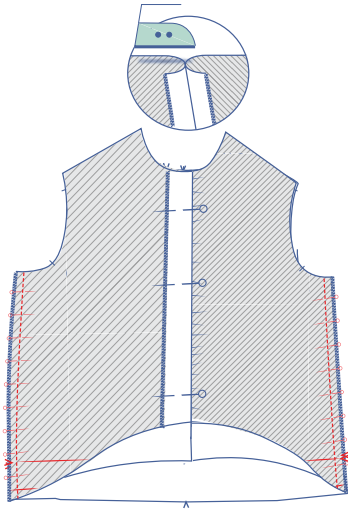

3

Pin and sew the side seams together. Press the seam allowance open.

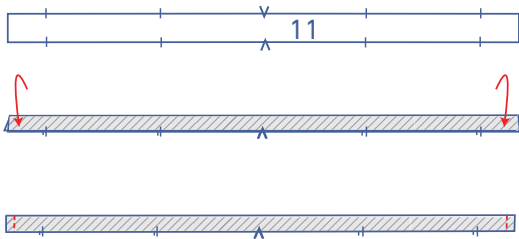

4

Fold the collar ruffle (11) in half lengthwise with the right sides of the fabric touching. Sew the two short ends.

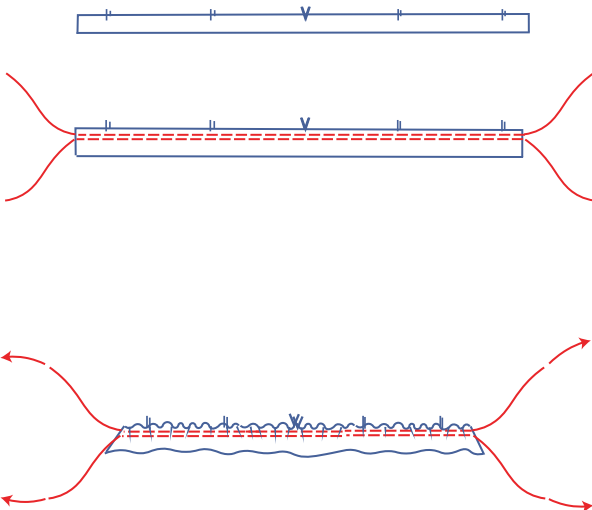

Turn the right way out. Use a long stitch at a low thread tension to sew two parallel rows of stitching down the full length of the raw edges. Leave long thread tails at the beginning and at the end.

Carefully tug the ends of the gathering threads to create ruffles in the fabric.

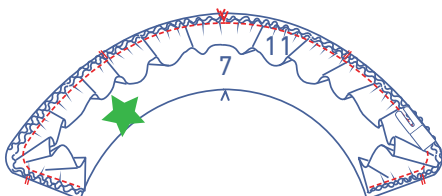

Pin the raw edges of the collar ruffle to the raw edge of one of the two collar pieces (7). Distribute the ruffles until the notches in the ruffled trim and the collar are matching. Sew the ruffled trim to the collar close to the edge within the 3/8" seam allowance.

Pin the remaining collar piece on top of the collar + ruffled trim with the right side facing down as shown.

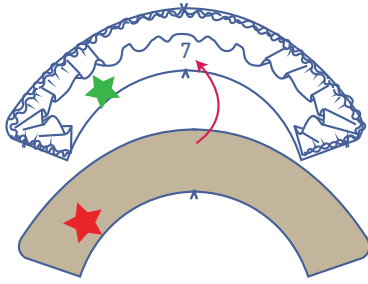

Stitch the contours of the collars pieces together, except at the bottom.

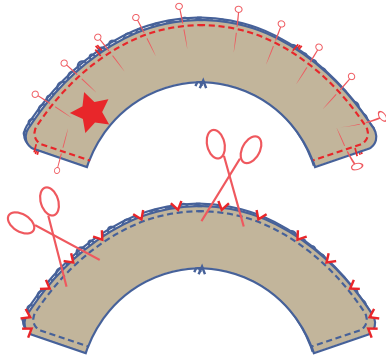

Trim the seam allowance.

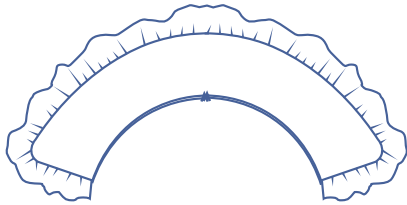

Turn the right way out.

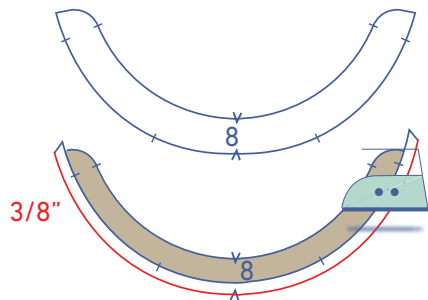

Press one of the two collar bands (8) 3/8" over to the wrong side at the bottom.

Stack both collar bands with the right sides facing. The collar band with the pressed bottom should be on top.

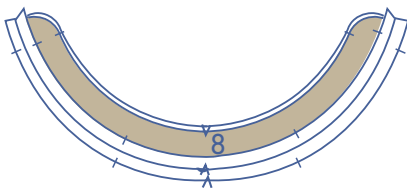

Slide the collar between the two collar bands with the under collar (= red-star collar) facing up and make sure the raw edges are matching.

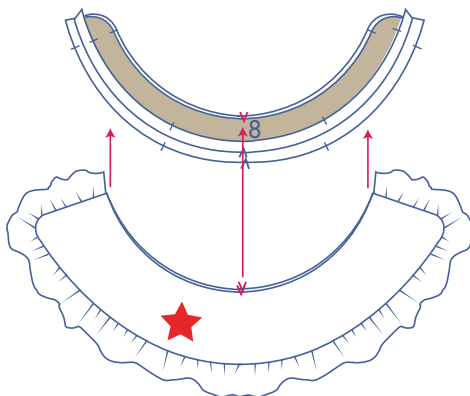

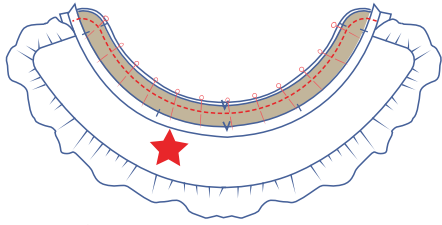

Pin and sew the pieces together.

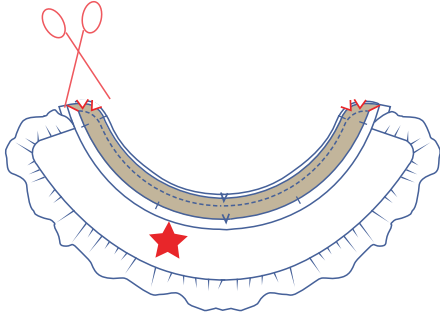

Trim the seam allowances at the curves to prevent any bunching.

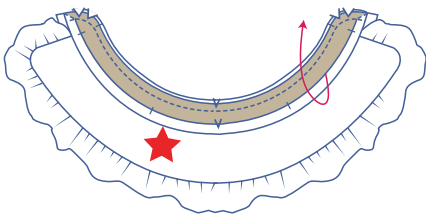

Now, turn the collar bands the right way out.

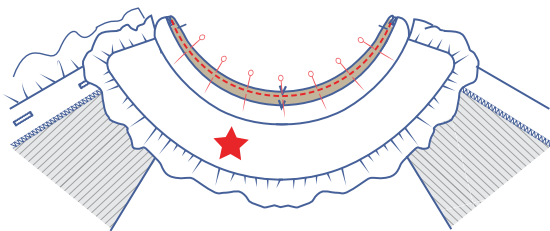
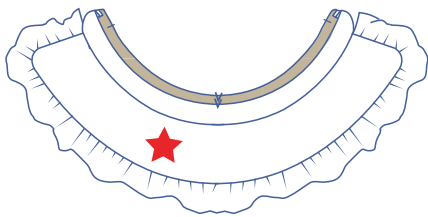

Pin and sew the bottom of the unpressed collar band to the neckline along the wrong side of the top.

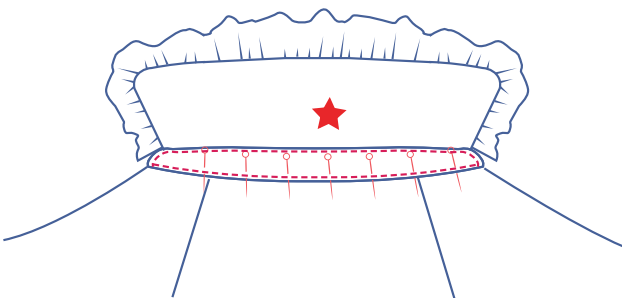

Fold the collar band with the pressed bottom over towards the right side of the neckline. The fold line should be directly over the previous stitching. Pin and sew into place. Finish topstitching all the way around.

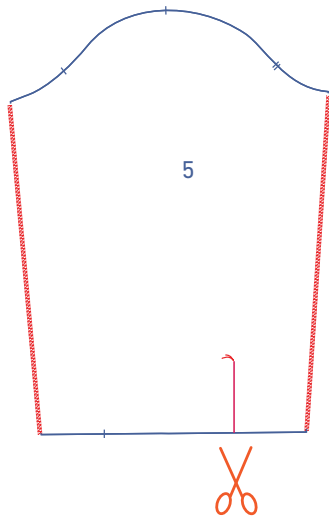

5

Finish the sides of the sleeve (5) with overlock stitching. Snip into the sleeve from the notch in the hem up to the marking thread.

Press the sleeve split bias tape (12) as follows:

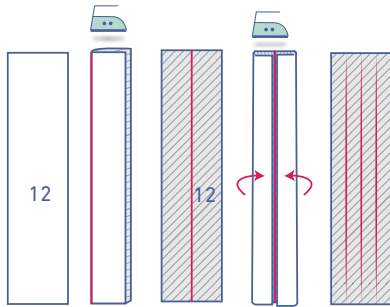

- First, press the bias tape in half lengthwise all the way down to create a fold line.
- Now, press the long ends in so that the raw edges line up with the centre fold line.
- Press in half.
- Open the bias tape back out.

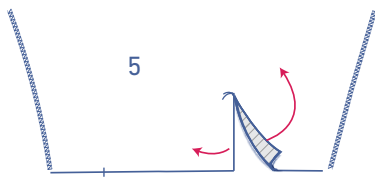

Open the sleeve at the split so that you end up with a single straight line.

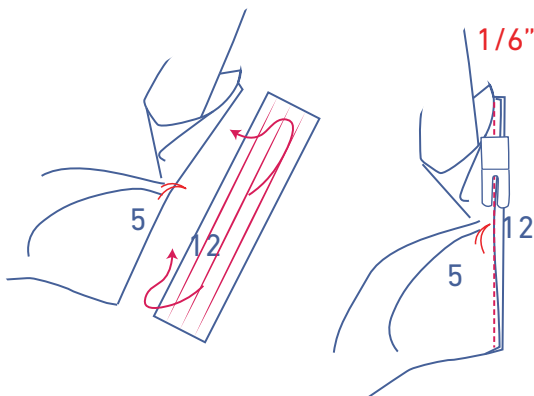
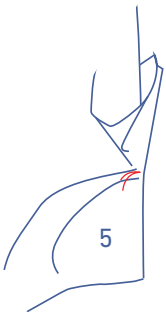

Slide the sleeve split bias tape under the sleeve with the right side facing up. Line up the long ends of the bias tape with the edges of the sleeve splits. At the marking thread, pull the sleeve a little to the side. Sew into place at 1/6". You'll only have sewn a tiny bit of fabric at the marking thread point.

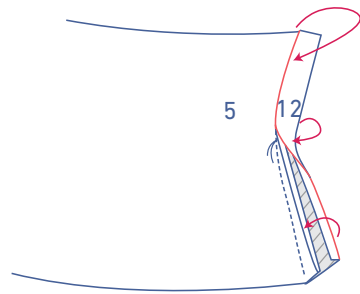

Fold the bias tape onto the right side of the sleeve. Tuck the raw edge under and place the pressed fold line directly over the previous stitching. Sew into place right next to the edge.

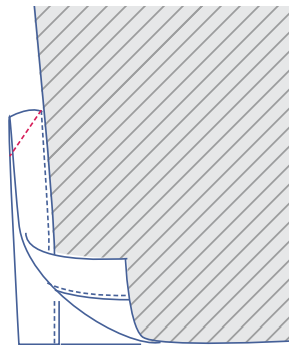
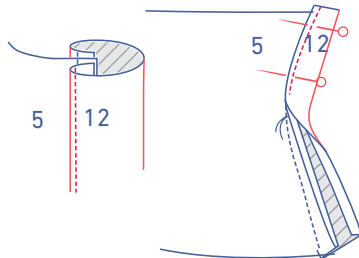

Fold the sleeve in half crosswise, with the right sides touching. Sew the top of the bias tape together at an angle.

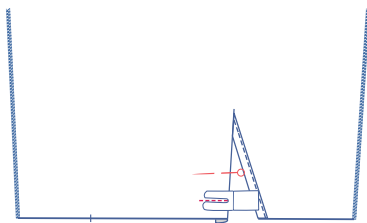

Fold the bias tape on the sleeve front (recognisable because it is the widest side of the sleeve at the hem) over towards the wrong side of the sleeve and sew the bias tape into place at presser foot width from the bottom.

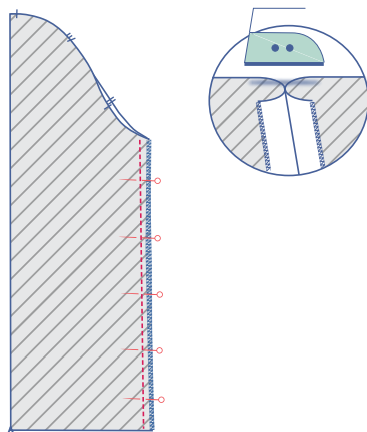

Pin and sew the sleeve sides. Press all of the seam allowance open.

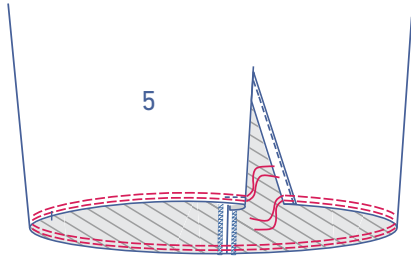

Using a long stitch length at a low thread tension, sew two parallel rows of stitching to the bottom of the sleeve. Leave long thread tails at the beginning and the end.

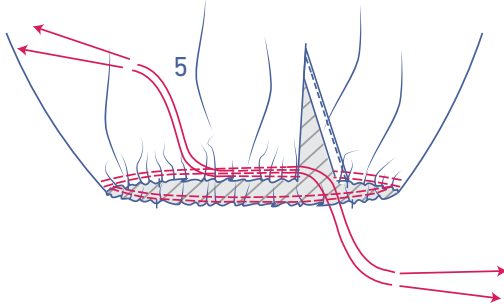

Carefully tug the gathering threads to create ruffles in the fabric.

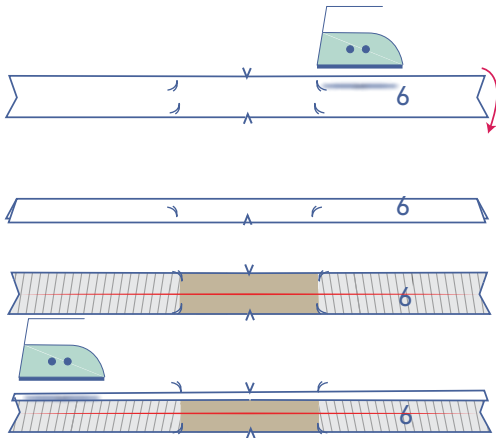

Press the cuff (6) in half lengthwise (wrong sides facing) to create a fold line and open back out. Next, press one long end on each cuff piece 3/8" over.

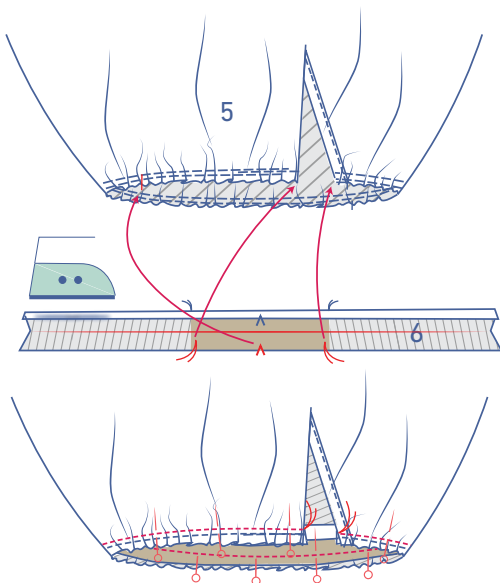

Slide the cuff inside the sleeve as shown. Pin the unpressed raw edge of the cuff to the wrong side of the sleeve, with the V notch matching the notch in the sleeve. The marking threads should align with the edges of the sleeve as shown. Sew into place between the marking threads.

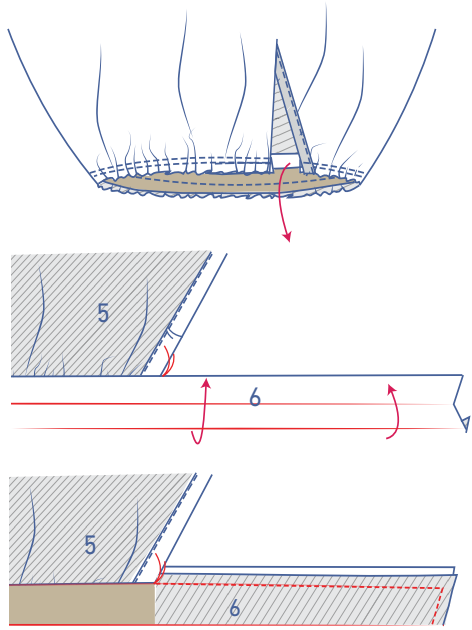

First, fold the cuff + ties all the way out towards the bottom.

Fold the ties next to the marking threads in half with the right sides touching. Sew each of the short and long ends closed (as shown).

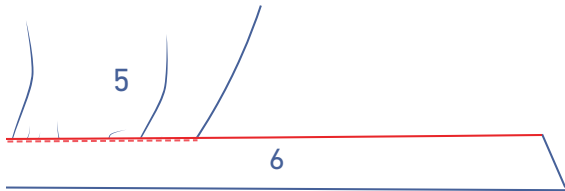

Turn the ties the right way out. Tuck the raw edge of the cuff under and place the fold line directly over the previous stitching. Stitch into place right next to the edge.

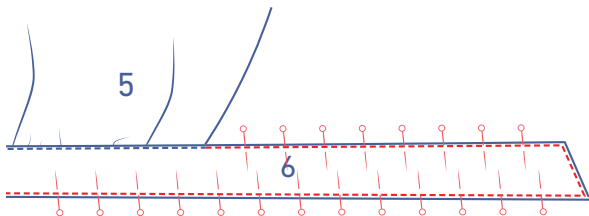

Finish the topstitching all the way around.

6

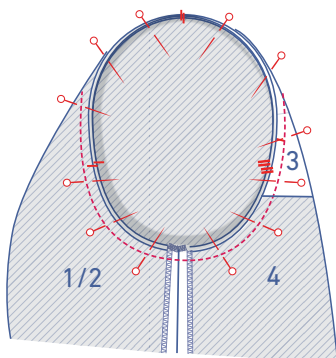

Pin the sleeve cap to the armhole with the notches matching. The notch in the sleeve should match the single notch in the front, and the double notch in the sleeve should match the double notch in the back. The top single notch in the sleeve matches the single notch in the yoke that marks the true shoulder. Distribute the excess fabric between the top notches. Sew into place.

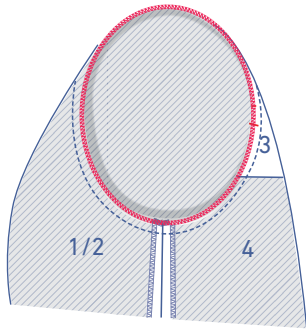

Finish the raw edges together with overlock stitching.

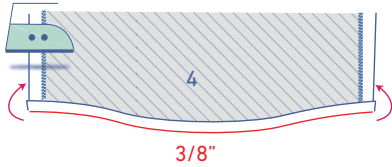

7

First, press the hem allowance of the back over 3/8", and then press it over another 2".

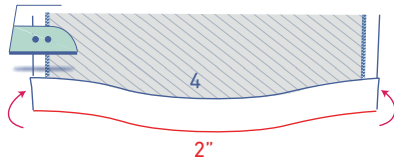

Sew the hem allowance into place at 1.8" from the edge.

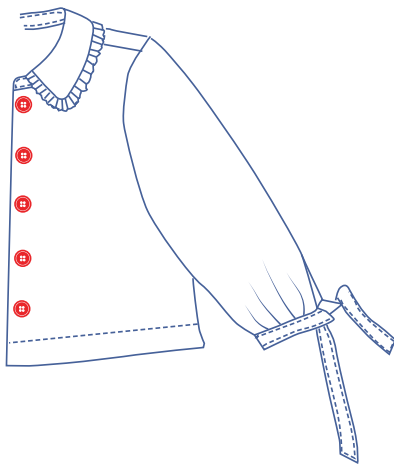
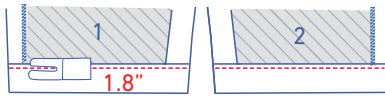

8

Sew the buttons onto the LF where indicated. The position of the top and bottom buttons has been marked on the pattern for you. Divide the distance between both evenly to determine the locations of the other buttons. Or you can sew the buttons on to match the buttonholes you made earlier.

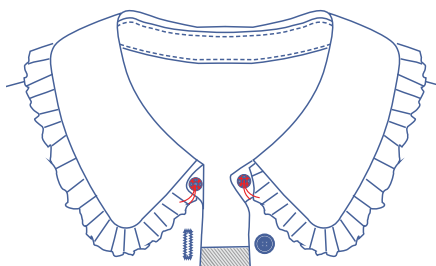

Sew a snap onto the collar band.