

O'REILLY®

Second
Edition

Designing Distributed Systems

Patterns and Paradigms for Scalable,
Reliable Systems Using Kubernetes



Brendan Burns

Praise for *Designing Distributed Systems*

An essential guide for anyone working with scalable and reliable systems, especially in the context of Kubernetes. Burns brings clarity to complex distributed systems concepts and provides practical design patterns, making this book invaluable for engineers looking to build robust systems in modern, cloud native environments.

—Rajeev Reddy Vishaka, software engineering leader,
Coinbase

Designing Distributed Systems by Brendan Burns offers an in-depth exploration of key distributed system concepts, from stateless and sharded services to event-driven processing and observability. A must-read for SREs and engineers looking to harness the full power of Kubernetes to build resilient, high-performance infrastructures.

—Swapnil Shevate, site reliability engineering
professional and advocate

A brilliant resource that simplifies the complexity of distributed systems. Brendan Burns offers practical patterns and design paradigms that are indispensable for building modern cloud native applications.

—Lalithkumar Prakashchand, software engineer, Meta
Platforms

Designing Distributed Systems, 2nd ed., remains an excellent book for introducing developers to architectural concepts that add both resilience and greater efficiency to new and legacy systems. The book describes a set of simple patterns that work particularly well with Kubernetes and are a great place to start building better systems in the field.

—Anne Currie, CEO, Strategically Green Learning and
Development, and author, *Building Green Software*

Designing Distributed Systems

SECOND EDITION

Patterns and Paradigms for Scalable, Reliable Systems Using Kubernetes

Brendan Burns

O'REILLY®

Designing Distributed Systems

by Brendan Burns

Copyright © 2025 Brendan Burns. All rights reserved.

Printed in the United States of America.

Published by O'Reilly Media, Inc., 1005 Gravenstein Highway North,
Sebastopol, CA 95472.

O'Reilly books may be purchased for educational, business, or sales promotional use. Online editions are also available for most titles (<http://oreilly.com>). For more information, contact our corporate/institutional sales department: 800-998-9938 or *corporate@oreilly.com*.

- Acquisitions Editor: Louise Corrigan
- Development Editor: Jill Leonard
- Production Editor: Elizabeth Faerm
- Copyeditor: Dwight Ramsey
- Proofreader: Emily Wydeven
- Indexer: Potomac Indexing, LLC

- Interior Designer: David Futato
- Cover Designer: Karen Montgomery
- Illustrator: Kate Dullea

- December 2024: Second Edition

Revision History for the Second Edition

- 2024-12-04: First Release

See <http://oreilly.com/catalog/errata.csp?isbn=9781098156350> for release details.

The O'Reilly logo is a registered trademark of O'Reilly Media, Inc. *Designing Distributed Systems*, the cover image, and related trade dress are trademarks of O'Reilly Media, Inc.

The views expressed in this work are those of the author and do not represent the publisher's views. While the publisher and the author have used good faith efforts to ensure that the information and instructions contained in this work are accurate, the publisher and the author disclaim all responsibility for errors or omissions, including without limitation responsibility for damages resulting from the use of or reliance on this work. Use of the information and instructions contained in this work is at

your own risk. If any code samples or other technology this work contains or describes is subject to open source licenses or the intellectual property rights of others, it is your responsibility to ensure that your use thereof complies with such licenses and/or rights.

978-1-098-15635-0

[LSI]

Preface

Who Should Read This Book

At this point, nearly every developer is a developer or consumer (or both) of distributed systems. Even relatively simple mobile applications are backed with cloud APIs so that their data can be present on whatever device the customer happens to be using. Whether you are new to developing distributed systems or an expert with scars on your hands to prove it, the patterns and components described in this book can transform your development of distributed systems from art to science. Reusable components and patterns for distributed systems will enable you to focus on the core details of your application. This book will help any developer become better, faster, and more efficient at building distributed systems.

Why I Wrote This Book

Throughout my career as a developer of a variety of software systems, from web search to the cloud, I have built a large number of scalable, reliable distributed systems. Each of these systems was, by and large, built from scratch. In general, this is true of all distributed applications. Despite having many of the same concepts and even at times nearly identical logic, the ability to apply patterns or reuse components is often very, very

challenging. This forced me to waste time reimplementing systems, and each system ended up less polished than it might have otherwise been.

The recent introduction of containers and container orchestrators fundamentally changed the landscape of distributed system development. Suddenly we have an object and interface for expressing core distributed system patterns and building reusable containerized components. I wrote this book to bring together all of the practitioners of distributed systems, giving us a shared language and common standard library so that we can all build better systems more quickly.

The World of Distributed Systems Today

Once upon a time, people wrote programs that ran on one machine and were also accessed from that machine. The world has changed. Now, nearly every application is a *distributed system* running on multiple machines and accessed by multiple users from all over the world. Despite their prevalence, the design and development of these systems is often a black art practiced by a select group of wizards. But as with everything in technology, the world of distributed systems is advancing, regularizing, and abstracting. In this book I capture a collection of repeatable, generic patterns that can make the development of reliable distributed systems more approachable and efficient. The adoption of patterns and reusable components frees developers from reimplementing the same systems over

and over again. This time is then freed to focus on building the core application itself.

Navigating This Book

This book is organized into five parts as follows:

Part I, “Foundational Concepts”

Chapters [1](#) and [2](#) introduce distributed systems as well as some fundamental concepts which are essential to understanding the distributed system designs described in [Part II, “Single-Node Patterns”](#).

Part II, “Single-Node Patterns”

Chapters [3](#) through [5](#) discuss reusable patterns and components that occur on individual nodes within a distributed system. They cover the sidecar, adapter, and ambassador single-node patterns.

Part III, “Serving Patterns”

Chapters [6](#) through [8](#) cover multinode distributed patterns for long-running serving systems like web applications. Patterns for many different types of serving systems, including basic replication, sharding, and work sharing, are discussed. Additionally, Chapters [9](#) and [10](#) discuss essential distributed concepts like functions, event-driven programming, and leader election.

Part IV, “Batch Computational Patterns”

Chapters [11](#) through [13](#) cover distributed system patterns for large-scale batch data processing regarding work queues, event-based processing, and coordinated workflows.

Part V, “Universal Concepts”

The book concludes with several topics that are universal to all distributed systems. [Chapter 14](#) covers logging, monitoring, and alerting for your application; [Chapter 15](#) provides a survey of AI infrastructure; and [Chapter 16](#) describes many common failures and design errors that occur over and over again as we build distributed systems.

If you are an experienced distributed systems engineer, you can likely skip Chapters [1](#) and [2](#), though you may want to skim them to understand how I expect these patterns to be applied and why I think the general notion of distributed system patterns is so important.

You will likely find utility in the single-node patterns, as they are the most generic and most reusable patterns in the book.

Depending on your goals and the systems you are interested in developing, you can choose to focus on either large-scale big data patterns or patterns for long-running servers (or both). The two parts are largely independent from each other and can be read in any order.

Likewise, if you have extensive distributed system experience, you may find that some of the early patterns chapters (e.g., [Part III](#) on naming, discovery, and load balancing) are redundant with what you already know, so feel free to skim through to gain the high-level insights—but don't forget to look at all of the pretty pictures!

Conventions Used in This Book

The following typographical conventions are used in this book:

Italic

Indicates new terms, URLs, email addresses, filenames, and file extensions.

`Constant width`

Used for program listings, as well as within paragraphs to refer to program elements such as variable or function names, databases, data types, environment variables, statements, and keywords.

`Constant width italic`

Shows text that should be replaced with user-supplied values or by values determined by context.

NOTE

This element signifies a general note.

Online Resources

Though this book describes generally applicable distributed system patterns, it expects that readers are familiar with containers and container orchestration systems. If you don't have a lot of preexisting knowledge about these things, I recommend the following resources:

- [Docker](#)
- [Kubernetes](#)
- [DC/OS](#)

Using Code Examples

Supplemental material (code examples, exercises, etc.) is available for download at <https://github.com/brendandburns/designing-distributed-systems>.

If you have a technical question or a problem using the code examples, please send email to support@oreilly.com.

This book is here to help you get your job done. In general, if example code is offered with this book, you may use it in your programs and documentation. You do not need to contact us for permission unless you're reproducing a significant portion of the code. For example, writing a program that uses several chunks of code from this book does not require permission. Selling or distributing examples from O'Reilly books does require permission. Answering a question by citing this book and quoting example code does not require permission. Incorporating a significant amount of example code from this book into your product's documentation does require permission.

We appreciate, but generally do not require, attribution. An attribution usually includes the title, author, publisher, and ISBN. For example: “*Designing Distributed Systems* by Brendan Burns (O'Reilly). Copyright 2025 Brendan Burns, 978-1-098-15635-0.”

If you feel your use of code examples falls outside fair use or the permission given above, feel free to contact us at permissions@oreilly.com.

O'Reilly Online Learning

NOTE

For more than 40 years, [O'Reilly Media](#) has provided technology and business training, knowledge, and insight to help companies succeed.

Our unique network of experts and innovators share their knowledge and expertise through books, articles, and our online learning platform.

O'Reilly's online learning platform gives you on-demand access to live training courses, in-depth learning paths, interactive coding environments, and a vast collection of text and video from O'Reilly and 200+ other publishers. For more information, visit <https://oreilly.com>.

How to Contact Us

Please address comments and questions concerning this book to the publisher:

- O'Reilly Media, Inc.
- 1005 Gravenstein Highway North
- Sebastopol, CA 95472
- 800-889-8969 (in the United States or Canada)
- 707-827-7019 (international or local)
- 707-829-0104 (fax)
- support@oreilly.com
- <https://oreilly.com/about/contact.html>

We have a web page for this book, where we list errata, examples, and any additional information. You can access this page at

<https://oreil.ly/designing-distributed-systems-2e>.

For news and information about our books and courses, visit

<https://oreilly.com>.

Find us on LinkedIn: <https://linkedin.com/company/oreilly-media>.

Watch us on YouTube: <https://youtube.com/oreillymedia>.

Acknowledgments

I'd like to thank my wife, Robin, and my children for everything they do to keep me happy and sane. To all of the people along the way who took the time to help me learn all of these things, many thanks! Also thanks to my parents for that first SE/30.

I would also like to thank the technical reviewers who took time to provide their feedback and make this book better:

- Dinesh Reddy Chittibala
- Anne Currie
- Chris Devers
- Werner Dijkerman

- Sukanya Moorthy
- Lalithkumar Prakashchand
- William Jamir Silva
- Rajeev Reddy Vishaka

Finally, I would like to thank the staff at O'Reilly and everyone who provided feedback for the first edition of this book. You've helped me make a better book, and I'm grateful.

Part I. Foundational Concepts

Before we get started describing distributed systems, there are motivations and concepts that form the foundation of both why and how we build distributed systems. This section covers these foundational concepts to provide a basis for the rest of the book.

Distributed systems don't exist in a vacuum. The development of such systems is based on the evolving role of both computing and online systems in business and entertainment. In particular, in the development of always-on, mission-critical systems that we rely on every day. Additionally, the development of modern distributed systems is based on the history of how such systems have been designed and built in the past. This history of both how the systems are built, and often more importantly how they have failed, has led us to the current containerized and microservice architectures that you find in this book.

Before the design of distributed systems can be described, it is necessary to have a grounding in core concepts for how server systems operate, as well as fundamental computer science concepts like locking and APIs. It is also necessary to have a grounding in basic operations for distributed systems, such as monitoring and logging. Finally, because distributed systems involve numerous interactions across many different systems and many different requests, it is necessary to have a basic understanding of statistics

and how we can measure the common behavior across the system through observing multiple different requests on different machines.

After reading these introductory chapters, you should have the foundational grounding in the context, history, and concepts necessary to understand how the design of these systems is described. This grounding also helps explain why some of the seemingly complex aspects of the design become necessary for reliability or scale.

Chapter 1. Introduction

Today's world of always-on applications and APIs has availability and reliability requirements that would have been required of only a handful of mission-critical services around the globe only a few decades ago.

Likewise, the potential for rapid, viral growth of a service means that every application has to be built to scale nearly instantly in response to user demand. These constraints and requirements mean that almost every application that is built—whether it is a consumer mobile app or a backend payments application—needs to be a distributed system.

But building distributed systems is challenging. Often, they are one-off bespoke solutions. In this way, distributed system development bears a striking resemblance to the world of software development prior to the development of modern object-oriented programming languages.

Fortunately, as with the development of object-oriented languages, there have been technological advances that have dramatically reduced the challenges of building distributed systems. In this case, it is the rising popularity of containers and container orchestrators. As with the concept of objects within object-oriented programming, these containerized building blocks are the basis for the development of reusable components and patterns that dramatically simplify and make accessible the practices of building reliable distributed systems. In the following introduction, we give a brief history of the developments that have led to where we are today.

A Brief History of Systems Development

In the beginning, there were machines built for specific purposes, such as calculating artillery tables or the tides, breaking codes, or other precise, complicated but rote mathematical applications. Eventually these purpose-built machines evolved into general-purpose programmable machines. And eventually they evolved from running one program at a time to running multiple programs on a single machine via time-sharing operating systems, but these machines were still disjoint from each other.

Gradually, machines came to be networked together, and client-server architectures were born so that a relatively low-powered machine on someone's desk could be used to harness the greater power of a mainframe in another room or building. While this sort of client-server programming was somewhat more complicated than writing a program for a single machine, it was still fairly straightforward to understand. The client(s) made requests; the server(s) serviced those requests.

In the early 2000s, the rise of the internet and large-scale data centers consisting of thousands of relatively low-cost commodity computers networked together gave rise to the widespread development of *distributed systems*. Unlike client-server architectures, distributed system applications are made up of multiple different applications running on different machines, or many replicas running across different machines, all

communicating together to implement a system like web search or a retail sales platform.

Because of their distributed nature, when structured properly, distributed systems are inherently more reliable. And when architected correctly, they can lead to much more scalable organizational models for the teams of software engineers that built these systems. Unfortunately, these advantages come at a cost. These distributed systems can be significantly more complicated to design, build, and debug correctly. The engineering skills needed to build a reliable distributed system are significantly higher than those needed to build single-machine applications like mobile or web frontends. Regardless, the need for reliable distributed systems only continues to grow. Thus, there is a corresponding need for the tools, patterns, and practices for building them.

Fortunately, technology has also increased the ease with which you can build distributed systems. Containers, container images, and container orchestrators have all become popular in recent years because they are the foundation and building blocks for reliable distributed systems. Using containers and container orchestration as a foundation, we can establish a collection of patterns and reusable components. These patterns and components are a toolkit that we can use to build our systems more reliably and efficiently.

A Brief History of Patterns in Software Development

This is not the first time such a transformation has occurred in the software industry. For a better context on how patterns, practices, and reusable components have previously reshaped systems development, it is helpful to look at past moments when similar transformations have taken place.

Formalization of Algorithmic Programming

Though people had been programming for more than a decade before its publication in 1962, Donald Knuth's collection, *The Art of Computer Programming* (Addison-Wesley Professional), marks an important chapter in the development of computer science. In particular, the books contain algorithms not designed for any specific computer, but rather to educate the reader on the algorithms themselves. These algorithms then could be adapted to the specific architecture of the machine being used or the specific problem that the reader was solving. This formalization was important because it provided users with a shared toolkit for building their programs, but also because it showed that there was a general-purpose concept that programmers should learn and then subsequently apply in a variety of different contexts. The algorithms themselves, independent of any specific problem to solve, were worth understanding for their own sake.

Patterns for Object-Oriented Programming

Knuth's books represent an important landmark in the thinking about computer programming, and algorithms represent an important component in the development of computer programming. However, as the complexity of programs grew, and the number of people writing a single program grew from the single digits to the double digits and eventually to the thousands, it became clear that procedural programming languages and algorithms were insufficient for the tasks of modern-day programming. These changes in computer programming led to the development of object-oriented programming languages, which elevated data, reusability, and extensibility to peers of the algorithm in the development of computer programs.

In response to these changes to computer programming, there were changes to the patterns and practices for programming as well. Throughout the early to mid-1990s, there was an explosion of books on patterns for object-oriented programming. The most famous of these is the "gang of four" book, *Design Patterns: Elements of Reusable Object-Oriented Programming* by Erich Gamma et al. (Addison-Wesley Professional). *Design Patterns* gave a common language and framework to the task of programming. It described a series of interface-based patterns that could be reused in a variety of contexts. Because of advances in object-oriented programming and specifically interfaces, these patterns could also be implemented as generic reusable libraries. These libraries could be written

once by a community of developers and reused repeatedly, saving time and improving reliability.

The Rise of Open Source Software

Though the concept of developers sharing source code has been around nearly since the beginning of computing, and formal free software organizations have been in existence since the mid-1980s, the very late 1990s and the 2000s saw a dramatic increase in the development and distribution of open source software. Though open source is only tangentially related to the development of patterns for distributed systems, it is important in the sense that it was through the open source communities that it became increasingly clear that software development in general and distributed systems development in particular are community endeavors. It is important to note that all of the container technology that forms the foundation of the patterns described in this book has been developed and released as open source software. The value of patterns for both describing and improving the practice of distributed development is especially clear when you look at it from this community perspective.

NOTE

What is a pattern for a distributed system? There are plenty of instructions out there that will tell you how to install specific distributed systems (such as a NoSQL database). Likewise, there are recipes for a specific collection of systems (like a MEAN stack). But when I speak of patterns, I'm referring to general blueprints for organizing distributed systems, without mandating any specific technology or application choices. The purpose of a pattern is to provide general advice or structure to guide your design. The hope is that such patterns will guide your thinking and also be generally applicable to a wide variety of applications and environments.

The Value of Patterns, Practices, and Components

Before spending any of your valuable time reading about a series of patterns that I claim will improve your development practices, teach you new skills, and—let's face it—change your life, it's reasonable to ask: “Why?” What is it about the design patterns and practices that can change the way that we design and build software? In this section, I'll lay out the reasons I think this is an important topic, and hopefully convince you to stick with me for the rest of the book.

Standing on the Shoulders of Giants

As a starting point, the value that patterns for distributed systems offer is the opportunity to figuratively stand on the shoulders of giants. It's rarely the case that the problems we solve or the systems we build are truly

unique. Ultimately, the combination of pieces that we put together and the overall business model that the software enables may be something that the world has never seen before. But the way the system is built and the problems it encounters as it aspires to be reliable, agile, and scalable are not new.

This, then, is the first value of patterns: they allow us to learn from the mistakes of others. Perhaps you have never built a distributed system before, or perhaps you have never built this type of distributed system. Rather than hoping that a colleague has some experience in this area or learning by making the same mistakes that others have already made, you can turn to patterns as your guide. Learning about patterns for distributed system development is the same as learning about any other best practice in computer programming. It accelerates your ability to build software without requiring that you have direct experience with the systems, mistakes, and firsthand learning that led to the codification of the pattern in the first place.

A Shared Language for Discussing Our Practice

Learning about and accelerating our understanding of distributed systems is only the first value of having a shared set of patterns. Patterns have value even for experienced distributed system developers who already understand them well. Patterns provide a shared vocabulary that enables us to understand each other quickly. This understanding forms the basis for knowledge sharing and further learning.

To better understand this, imagine that we both are using the same object to build our house. I call that object a “Foo” while you call that object a “Bar.” How long will we spend arguing about the value of a Foo versus that of a Bar, or trying to explain the differing properties of Foo and Bar until we figure out that we’re speaking about the same object? Only once we determine that Foo and Bar are the same can we truly start learning from each other’s experience.

Without a common vocabulary, we waste time in arguments of “violent agreement” or in explaining concepts that others understand but know by another name. Consequently, another significant value of patterns is to provide a common set of names and definitions so that we don’t waste time worrying about naming, and instead get right down to discussing the details and implementation of the core concepts.

I have seen this happen in my short time working on containers. Along the way, the notion of a *sidecar* container (described in [Chapter 3](#) of this book) took hold within the container community. Because of this, we no longer have to spend time defining what it means to be a sidecar and can instead jump immediately to how the concept can be used to solve a particular problem. “If we just use a sidecar” ... “Yeah, and I know just the container we can use for that.” This example leads to the third value of patterns: the construction of reusable components.

Shared Components for Easy Reuse

Beyond enabling people to learn from others and providing a shared vocabulary for discussing the art of building systems, patterns provide another important tool for computer programming: the ability to identify common components that can be implemented once.

If we had to create all of the code that our programs use ourselves, we would never get done. Indeed, we would barely get started. Today, every system ever written stands on the shoulders of thousands if not hundreds of thousands of years of human effort. Code for operating systems, printer drivers, distributed databases, container runtimes, and container orchestrators—indeed, the entirety of applications that we build today are built with reusable shared libraries and components.

Patterns are the basis for the definition and development of such reusable components. The formalization of algorithms led to reusable implementations of sorting and other canonical algorithms. The identification of interface-based patterns gave rise to a collection of generic object-oriented libraries implementing those patterns.

Identifying core patterns for distributed systems enables us to build shared common components. Implementing these patterns as container images with HTTP-based interfaces means they can be reused across many different programming languages. And, of course, building reusable components improves the quality of each component because the shared

codebase gets sufficient usage to identify bugs and weaknesses, and sufficient attention to ensure that they get fixed.

More recently, a series of software supply chain attacks has made dependencies and dependency management a critical part of securing our applications. In the context of a secure software supply chain, these shared components take on even more importance. Every library or application that we use brings in more dependencies—and consequently, more risk. Relying on a single shared implementation of a core idea reduces the total amount of software that the world needs to depend on, and by focusing attention on a few dependencies, significantly improves the chances that they are properly maintained and protected from software supply chain attacks.

Summary

Distributed systems are required to implement the level of reliability, agility, and scale expected of modern computer programs. Distributed system design continues to be more of a black art practiced by wizards than a science applied by laypeople. The identification of common patterns and practices has regularized and improved the practice of algorithmic development and object-oriented programming. It is this book's goal to do the same for distributed systems. Enjoy!

Chapter 2. Important Distributed System Concepts

Before we get too deep into the design of distributed systems, it is valuable to ground ourselves in some key concepts that underpin the development of these distributed systems. If you are already experienced in distributed systems or systems design in general, some of these ideas may be familiar to you, and you may want to skip ahead, but hopefully at the completion of this chapter, you will have a core foundation for the patterns and designs presented throughout the rest of the book.

APIs and RPCs

Application programming interfaces, or APIs, form the core of any distributed system. You may have seen APIs in the context of programming language libraries or calls to operating system APIs. In distributed systems the idea is similar, but the API calls take place over the network between remote services. These calls are referred to as “RPCs” or “remote procedure calls.” RPCs rely on an underlying network transport, commonly, though not exclusively, the HTTP protocol and the JSON object format. Numerous other more structured protocols have existed over the years, from CORBA to gRPC as well as database-specific protocols. Though such systems provide capabilities beyond HTTP + JSON (also referred to as REST or

RESTful), these continue to be the most popular because of their wide support, simplicity, and ease of integration with web-based frontends.

APIs can be synchronous or asynchronous. Synchronous APIs return only after the request has been fully processed, while asynchronous APIs accept the request and return an operation ID for a background process that can be monitored via subsequent status requests. Synchronous APIs are the easiest to implement, but long-running operations are a bad match for HTTP or other network protocols because of timeouts and other limitations. Thus, if the length of your operation is measured in minutes, it is better off being modeled as an asynchronous operation.

APIs are generally not very useful without clients that can call those APIs. Having every developer hand-roll HTTP calls to your API is a recipe for unhappy developers and badly designed systems. In smaller systems, which may only be required to support individual languages, it is possible to handwrite these client libraries. But larger systems rely on IDLs, or interface description languages, such as OpenAPI, which can describe your API's structure in such a way that clients can be automatically generated for nearly any programming language.

Beyond the structure of your API, the core functionality of an API is described in terms of its SLO, its service level objectives, which describe how the API performs in terms of latency and reliability. Having formal

SLOs for latency, reliability, and throughput (requests per second) enables clients to successfully develop distributed systems.

Latency

One of the most important measures of your system's performance is the time that it takes to do something. This measure is commonly referred to as *latency*. Generally speaking, latency is measured in milliseconds, though depending on your system, it could be measured in microseconds (very fast) or seconds (very slow). When measuring latency, it is important to ensure that it is actually representative of end-user experience (see [“Percentiles”](#)) and that it is attributable, meaning you understand where the latency is coming from. Without proper attribution, you may understand that your system is slow, but you will have little idea about how to make it better.

Reliability

In addition to latency, reliability is obviously a key metric for any distributed system. At its simplest, reliability is just the fraction of successful requests relative to the total number of requests. But as with all things engineering, in the real world, the devil is in the details. Consider requests that are based on the HTTP(S) protocol. Using this protocol, you could measure the number of requests failed (i.e., requests that didn't

actually complete the HTTP protocol). However, for any reasonable web service, this number rapidly trends to zero. The reason for this is that HTTP itself has rich error semantics in the form of the HTTP response code. Thus, nearly every HTTP request succeeds at the protocol level, but often the response code indicates an error. From this, it is clear that our measure of reliability should not be at the HTTP protocol level, but rather at the HTTP response code level. However, HTTP defines a large number of response codes. Which should we treat as errors? It's fairly obvious that the 50x series of codes are true errors. Most of them represent either internal server errors (500) or network transmission errors (e.g., 502). Similarly it is fairly clear that the 20x series codes are successful requests. Unfortunately, in between 20x and 50x is a gray area. Typically we can consider the 30x (mostly redirects) status codes to be "successful," though an excessive number of redirects *can* be an error in some conditions. Most of the uncertainty lies in the 40x collection of errors. The 40x collection of status codes are the land of ambiguity. Is that 404 (not found) an indication that a client simply made a mistake? Or is your service somehow misconfigured to look for files in the wrong location? Similarly, it may seem obvious that 403 (unauthorized) represents a "client error," but what if your authorization service is having an outage?

Ultimately, though the examples above are drawn from the HTTP protocol, the important takeaway is that measuring reliability is both critical and complicated. In practice, treating 404 (not found) as a client error can mask true reliability problems and prevent you from alerting when there is a

customer-facing outage in your system. At the same time, a spike in 404 errors can also be from a single misconfigured client, causing noise and false alerts, which will plague your on-call engineers. In this gray area, proper monitoring will be application dependent. Further AI-based operations and anomaly detection become critical in differentiating between true problems and false alerts.

Percentiles

Throughout this book there are discussions of percentiles. The 99th percentile latency, for example. Percentiles are key to understanding distributed systems because distributed systems are inherently about serving large numbers of users and large numbers of requests. Of course, in serving lots of users, we want to understand the operation of our services. By default it is easy to use the average as the way in which we measure user experience. It makes sense. We want to understand the experience of the average user, so it makes sense to look at the average experience of our various metrics. Unfortunately, averages are often really distorted in considering the experience of a system. There are several reasons for this, but the two largest have to do with the calculation of the average as well as the ways in which individual metrics (e.g., request latency) come together in an end-to-end user experience. When you consider the arithmetic average, it is heavily skewed by either large or small outliers. Consider measuring latency, a relatively small number of users with very fast latency

will distort the average latency of your system and make you believe that your “average” performance is much better than it actually is.

The other reason that the average is problematic is that it considers individual requests separately; however, most user experiences are the combination of multiple requests which must succeed. The combining of all of these experiences means that almost no one actually has an “average” experience in terms of latency; instead, the probability that every user has at least one exceptionally slow request rapidly approaches 100% as the number of requests in an end-to-end experience increases.

For both of these reasons, to truly understand the behavior of your system, it is far more useful to consider the 90th or 99th percentile of your user experience. These percentiles represent the place in the distribution of latency where 90% or 99% of your users experience *lower* latency. For example, if your 99th percentile latency is one second, then 99% of your users have latency less than one second. This gives you a much better sense for the operation of your service, but importantly, even the 99th percentile suffers from the problems of multiple requests in a single end-to-end experience. Taken together, the 99th percentile latency of a single request rapidly becomes the 90th (or even 50th) percentile of an end-to-end experience with enough requests in that experience. Because of this, it is always worth understanding exactly *which* experiences you are measuring.

Idempotency

Designing distributed systems is, in many ways, the study of, and anticipation of, how systems can fail. Of course, we don't want our systems to fail, and thus, in order to compensate for when the underlying systems *do* fail, we introduce ideas that make it easier for us to restore our services. The first of these is the idea of *idempotency*. Idempotency is the notion that whether an action is performed a single time or many times, the result is identical. An example of an idempotent operation is the statement $X = 5$. No matter how many times you execute that operation, the result is the same. X always is equal to 5. Compare that with the statement $X = X + 1$. This operation is *not* idempotent. Each time it's executed, the value of X increments by one. It is clear that the eventual value of X is dependent on the number of times that instruction is executed. If you are familiar with the ideas of infrastructure as code and declarative configuration, idempotency maps directly to declarative versus imperative configuration.

Idempotency is an important concept for distributed systems because it makes error and failure handling significantly easier. If we know that an operation is idempotent, in the face of failures, we can simply repeat it until it succeeds. No matter how many times it takes to get a successful outcome, we know that that outcome will always be the same. Idempotent operations make designing reliable systems easier.

Delivery Semantics

Though idempotency allows us to ignore the number of times a particular request has been made, sometimes it is necessary to actually control the number of times a particular request has been made in the presence of error conditions.

Generally, delivery of a message (or the success of a request) is divided into two categories. The first is “at least once” delivery. As its name suggests, at least once ensures that a message or a request will be delivered at least once to the recipient. The “at least” part is the important part, because with at least once delivery there are no guarantees about how many times a message will be received.

In contrast to “at least once” delivery, the alternative is “at most once” delivery, which ensures that a message can never be delivered more than once. As with at least once, the important part of this is the “at most” phrase, because with at most once delivery it is perfectly acceptable for a message to *never* be delivered. A good example of where you might want at most once delivery is the charging of a credit card. Clearly multiple identical charges to the same card are not allowable; “at most once” delivery assumes that in the presence of failure (e.g., the absence of payment) someone will try again.

You may notice that “exactly once” delivery is missing from the options described. This is because, in practice, exactly once delivery is exceptionally hard to achieve. You are far better designing systems which can handle either at most or at least once delivery.

Relational Integrity

The reason that message delivery semantics become so important is that they ultimately affect the data that is the core of our application. If the data is your bank account, the integrity (e.g., reliability) of that data is clearly a very important concern. Ensuring the reliability of a single data entry (e.g., the balance in your bank account) is important, but *relational integrity* is an equally important concern for distributed systems. Relational integrity refers to the integrity or accuracy of data stored in multiple different rows or stores within a system. For example, your bank balance might be stored as a pair of `(user-id, balance)`, and your address might be stored in a different store as `(user-id, address)`. The integrity of that data refers to whether there are strong guarantees that for every `user-id` in the balances table, there is a corresponding entry in the addresses table. If the code in your application relies on there being consistency between various data stores, then your code relies on strong relational integrity. If instead your code can handle cases in which data in multiple stores may not be fully in sync, your code does not rely on relational integrity. The reason that this becomes important is that maintaining relational integrity requires

carefully synchronizing changes to multiple data stores. This synchronization has significant performance and reliability implications. In particular, it requires distributed transactions across multiple different data stores, which requires distributed locks that make your system more complicated and less parallel. Relational integrity can generally be seen as the distinction between SQL and NoSQL data stores. Traditional databases and SQL go to great pains to ensure relational consistency between various tables, including transactions and rollback semantics. NoSQL data stores like Azure's CosmosDB and the open source Cassandra database favor more relaxed relational semantics, where everything is a key/value store and consistency is a problem for application code. In general, relational consistency can be seen as a trade-off between performance and code complexity. If you don't need performance, the consistency offered by a traditional SQL database can make your code much easier, while looser approaches facilitate increased parallelism and corresponding performance.

Data Consistency

Beyond relational consistency, there is another related, important dimension of consistency to consider, and that is data consistency. In any distributed system, data is replicated to ensure the availability of data in the face of errors. This data replication has performance implications, and it is important to decide whether your data requires *strong* or *eventual* consistency.

Clearly, consistency, the notion that the data written is the same in all locations, is a critically important part of data storage. But how quickly must that data be the same? That is what we are considering when we talk about data consistency. In a strongly consistent system, the data is guaranteed to be present everywhere before the writing of the data is considered to be “complete.” In an eventually consistent system, the data is guaranteed to be the same everywhere “eventually,” where eventually can actually mean a long-ish time.

To make this a little more concrete, consider a system which replicates its data to all of the data centers it maintains in the world. In a strongly consistent system, a user requests a write of some data item, and that data is immediately written to all of the different data centers. Until all of these data centers successfully acknowledge that the write has completed, the user request to write is not considered successful. At first blush, this seems like the right approach—until the data is everywhere, the user should not be told that their request is successful. Unfortunately, the result of this is significantly decreased performance. As the number of data centers grows, the number of required writes also grows, up until a point where every request is basically guaranteed to hit a data center which is running slowly or even failing. Thus, while strong consistency ensures data reliability, it significantly reduces write throughput.

In the previous example, an eventually consistent system might return as soon as a single data center has acknowledged the write. Replication to all

of the data centers is performed by an asynchronous background process, and the user doesn't have to wait around for it to complete. The system says "I got this," and the user trusts the system to eventually make the data consistent. Waiting only for a single write makes the system both more reliable and more performant. You are significantly less likely to hit a slow or failing data center with a single write.

Unfortunately, in many use cases eventual consistency gives the impression to the end user that the system is *less* reliable. The reason for this is the "read your own writes" problem. Distributed systems replicate themselves across multiple data centers for reliability and performance. Most of the time, a single user's requests will all go to the same data center, but occasionally, under load, failures, or other specific network conditions, different requests from the same user will go to different data centers. In an eventually consistent system, this means that after a user writes something to the system, a subsequent read that is load balanced to a different data center may not see the recent write. This can be quite distressing to a user. Imagine if you ordered something on a retail website, clicked on "view my orders," and couldn't see your order in the returned list. It's highly likely that you would never order from that site again.

Because of these complications, the choice between strong consistency and eventual consistency is never a very clean one. It depends on the use case as well as the performance requirements of the system. Be careful when deciding which approach to take with your system, though. The decision to

use strong or eventual consistency will permeate your system design and your application's code. Once written, it is very hard to change the storage model that is used by a distributed system, and the implications of the decision often take years to show up.

The trade-offs above between *consistency*, *availability*, and *partition tolerance* is known as the CAP theorem, and it states that you can build a system with two of the three attributes, e.g., a system that is consistent and available but not partition tolerant, but you can't build a system with all three. It's worth noting that the CAP theorem is not a draconian rule. You may not be able to build a system that guarantees all three, but it is possible to build a system where each are reasonable for your application. For some applications, 99% availability is sufficient, and thus, you can use that trade-off to ensure the consistency and partition tolerance you need as well. Effectively, the CAP theorem says that whenever you are optimizing one of the system characteristics, you are inherently trading off against other goals.

Orchestration and Kubernetes

Distributed systems defined today are not deployed in a vacuum or using only code written by the system's developers. Instead, the ubiquity of distributed systems today has meant that shared infrastructure has been built to support the deployment and operation of distributed systems. This infrastructure is commonly referred to as an orchestrator, because it

orchestrates the operation of the distributed system without implementing the details of the systems logic. The most common orchestrator is the open source Kubernetes system for orchestrating deployments of containerized applications. The orchestrator is responsible for taking the desired state of the application (e.g., I want three replicas of my frontend and five replicas of my backend) and ensuring that the real state of the system matches the desired state that has been declared.

Health Checks

To achieve successful orchestration, the orchestration system needs to understand the health of the pieces that make up the distributed system. Health is used to understand when an application is ready to be added to a load balancer, when an application is unhealthy and needs to be restarted, or when a rollout should be halted because the health of the application is impacted. While there are some basic aspects of health (e.g., is the program running) that the orchestrator can observe from outside the system, true understanding of your application requires that you implement health checks that are specific to your application. When providing health information to the orchestrator, there are two different notions of application health. The first is the simplest to understand, in that it simply represents whether or not your application is alive. Applications which are no longer responding to a *liveness* check should be terminated. And if a rollout is causing a significant degradation in the number of alive

applications, that rollout should be halted. The second notion of health is *readiness*. Readiness indicates that an application is ready to be used. At first blush, readiness and liveness would seem to be the same thing, but in many circumstances an application can be alive but not ready. The easiest example to understand is when an application has just started up and is initializing its state, perhaps by downloading and caching large files over the network. Such an application is alive, it is doing useful work and should not be terminated, but it is not ready until it has successfully downloaded and made ready to serve all of the files in its cache. By properly implementing both liveness and readiness checks, you can ensure that your distributed systems interact well with the orchestrator on which they run.

Summary

This chapter has described a number of key concepts that are foundational to the design and understanding of distributed systems. These concepts form the basis for both understanding the requirements and describing the characteristics of the systems that we build. Before going further into the book, make sure that they all feel intuitive and familiar to you.

Part II. Single-Node Patterns

This book concerns itself with distributed systems, which are applications made up of many different components running on many different machines. However, the first section of this book is devoted to patterns that exist on a single node. The motivation for this is straightforward.

Containers are the foundational building block for the patterns in this book, but in the end, groups of containers colocated on a single machine make up the atomic elements of distributed system patterns.

Though it is clear as to why you might want to break your distributed application into a collection of different containers running on different machines, it is perhaps somewhat less clear as to why you might also want to break up the components running on a single machine into different containers. To understand the motivation for these groups of containers, it is worth considering the goals behind containerization. In general, the goal of a container is to establish boundaries around specific resources (e.g., this application needs two cores and 8 GB of memory). Likewise, the boundary delineates team ownership (e.g., this team owns this image). Finally, the boundary is intended to provide separation of concerns (e.g., this image does this one thing).

All of these reasons provide motivation for splitting up an application on a single machine into a group of containers. Consider resource isolation first.

Your application may be made up of two components: one is a user-facing application server and the other is a background configuration file loader. Clearly, end-user-facing request latency is the highest priority, so the user-facing application needs to have sufficient resources to ensure that it is highly responsive. On the other hand, the background configuration loader is mostly a best-effort service; if it is delayed slightly during times of high user-request volume, the system will be OK. Likewise, the background configuration loader should not impact the quality of service that end users receive. For all of these reasons, you want to separate the user-facing service and the background shard loader into different containers. This allows you to attach different resource requirements and priorities to the two different containers and, for example, ensure that the background loader opportunistically steals cycles from the user-facing service whenever it is lightly loaded and the cycles are free. Likewise, separate resource requirements for the two containers ensure that the background loader will be terminated before the user-facing service if there is a resource contention issue caused by a memory leak or other overcommitment of memory resources.

In addition to this resource isolation, there are other reasons to split your single-node application into multiple containers. Consider the task of scaling a team. There is good reason to believe that the ideal team size is six to eight people. In order to structure teams in this manner and yet still build significant systems, we need to have small, focused pieces for each team to

own. Additionally, often some of the components, if factored properly, are reusable modules that can be used by many teams.

Consider, for example, the task of keeping a local filesystem synchronized with a Git source code repository. If you build this Git sync tool as a separate container, you can reuse it with PHP, HTML, JavaScript, Python, and numerous other web-serving environments. If you instead factor each environment as a single container where, for example, the Python runtime and the Git synchronization are inextricably bound, then this sort of modular reuse (and the corresponding small team that owns that reusable module) is impossible.

Finally, even if your application is small and all of your containers are owned by a single team, the separation of concerns ensures that your application is well understood and can easily be tested, updated, and deployed. Small, focused applications are easier to understand and have fewer couplings to other systems. This means, for example, that you can deploy the Git synchronization container without having to also redeploy your application server. This leads to rollouts with fewer dependencies and smaller scope. That, in turn, leads to more reliable rollouts (and rollbacks), which leads to greater agility and flexibility when deploying your application.

I hope that all of these examples have motivated you to think about breaking up your applications, even those on a single node, into multiple

containers. The following chapters describe some patterns that can help guide you as you build modular groups of containers. In contrast to later patterns we'll discuss, all of the patterns in this section assume tight dependencies between all containers. In particular, they assume that all of the containers in the pattern can be reliably coscheduled onto a single machine.

They also assume that all of the containers in the pattern can optionally share volumes or parts of their filesystems as well as other key container resources like network namespaces and shared memory. This tight grouping is called a *pod* in Kubernetes,¹ but the concept is generally applicable to different container orchestrators, though some support it more natively than others.

¹ [Kubernetes](#) is an open source system for automating deployment, scaling, and management of containerized applications. Check out my book, [Kubernetes: Up and Running](#) (O'Reilly).

Chapter 3. The Sidecar Pattern

The first single-node pattern is the sidecar pattern. The sidecar pattern is a single-node pattern made up of two containers. The first is the *application container*. It contains the core logic for the application. Without this container, the application would not exist. In addition to the application container, there is a *sidecar container*. The role of the sidecar is to augment and improve the application container, often without the application container's knowledge. In its simplest form, a sidecar container can be used to add functionality to a container that might otherwise be difficult to improve. Sidecar containers are coscheduled onto the same machine via an atomic *container group*, such as the `pod` API object in Kubernetes. In addition to being scheduled on the same machine, the application container and sidecar container share a number of resources, including parts of the filesystem, hostname, and network, and many other namespaces. A generic image of this sidecar pattern is shown in [Figure 3-1](#).

Container group (a.k.a. pod)

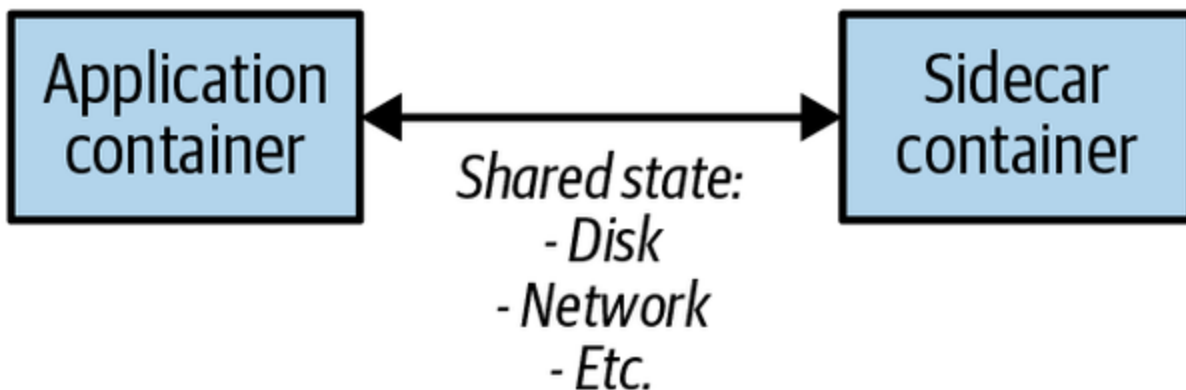

Figure 3-1. The generic sidecar pattern

An Example Sidecar: Adding HTTPS to a Legacy Service

Consider, for example, a legacy web service. Years ago, when it was built, internal network security was not as high a priority for the company, and thus, the application only services requests over unencrypted HTTP, not HTTPS. Due to recent security incidents, the company has mandated the use of HTTPS for all company websites. To compound the misery of the team sent to update this particular web service, the source code for this application was built with an old version of the company's build system, which no longer functions.

Containerizing this HTTP application is simple enough: the binary can run in a container with a version of an old Linux distribution on top of a more

modern kernel being run by the team's container orchestrator. However, the task of adding HTTPS to this application is significantly more challenging. The team is trying to decide between resurrecting the old build system versus porting the application's source code to the new build system, when one of the team members suggests that they use the sidecar pattern to resolve the situation more easily.

The application of the sidecar pattern to this situation is straightforward. The legacy web service can be configured to serve exclusively on localhost (127.0.0.1), which means that only services that share the local network with the server will be able to access the service. Normally, this wouldn't be a practical choice because it would mean that no one could access the web service. However, using the sidecar pattern, in addition to the legacy container, we will add an `nginx` sidecar container. This `nginx` container lives in the same network namespace as the legacy web application, so it can access the service that is running on localhost.

At the same time, this `nginx` service can terminate HTTPS traffic on the external IP address of the pod and proxy that traffic to the legacy web application (see [Figure 3-2](#)). Since this unencrypted traffic is only sent via the local loopback adapter inside the container group, the network security team is satisfied that the data is safe. Likewise, by using the sidecar pattern, the team has modernized a legacy application without having to figure out how to rebuild a new application to serve HTTPS. A similar form of this pattern can also be used to add automatic certificate rotation, or even

authentication and authorization to legacy web applications that may not be easy to modify.

Container group (a.k.a. pod)



Figure 3-2. The HTTPS sidecar

Dynamic Configuration with Sidecars

Simply proxying traffic into an existing application is not the only use for a sidecar. Another common example is configuration synchronization. Many older applications use a configuration file for parameterizing the application; this may be a raw text file or something more structured like TOML, XML, JSON, or YAML. Many preexisting applications were written to assume that this file was present on the filesystem and read their configuration from there. However, in a cloud native environment it is often quite useful to use an API for updating configuration stored elsewhere. This allows you to do a dynamic push of configuration information via an API instead of manually logging in to every server and updating the configuration file using imperative commands. The desire for such an API is driven both by ease of use as well as the ability to add automation like rollback, which makes configuring (and reconfiguring) safer and easier. Kubernetes supports `ConfigMap` resources for exactly this purpose.

Similar to the case of HTTPS, new applications can be written with the expectation that configuration is a dynamic property that should be obtained using a cloud API, but adapting and updating an existing application can be significantly more challenging. Fortunately, the sidecar pattern again can be used to provide new functionality that augments a legacy application without changing the existing application. For the sidecar pattern shown in [Figure 3-3](#), there again are two containers: the container that is the serving application and the container that is the configuration manager. The two containers are grouped together into a pod, where they share a directory between themselves. This shared directory is where the configuration file is maintained.

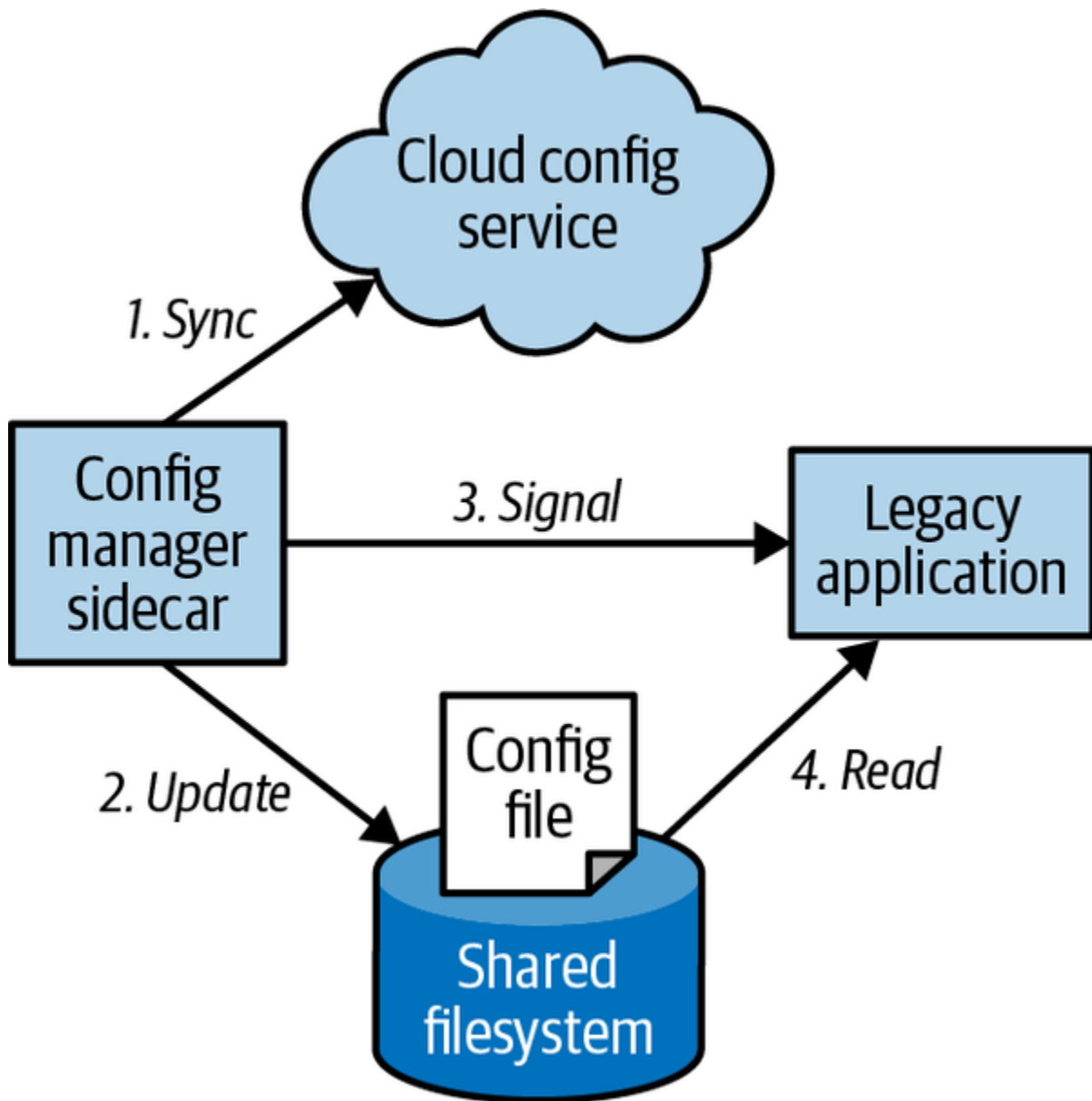

Figure 3-3. A sidecar example of managing a dynamic configuration

When the legacy application starts, it loads its configuration from the filesystem, as expected. This configuration is placed into the filesystem using a `ConfigMap` volume which places the current contents of a `ConfigMap` resource at a particular location in the filesystem. When the configuration manager starts, it examines the configuration API and looks

for differences between the local filesystem and the configuration stored in the API. If there are differences, the configuration manager downloads the new configuration to the local filesystem and signals to the legacy application that it should reconfigure itself with this new configuration. The actual mechanism for this notification varies by application. Some applications actually watch the configuration file for changes, while others respond to a SIGHUP signal. In extreme cases, the configuration manager may send a SIGKILL signal to abort the legacy application. Once aborted, the container orchestration system will restart the legacy application, at which point it will load its new configuration. As with adding HTTPS to an existing application, this pattern illustrates how the sidecar pattern can help adapt pre-existing applications to more cloud native scenarios.

Modular Application Containers

At this point, you might be forgiven if you thought that the sole reason for the sidecar pattern to exist was to adapt legacy applications where you no longer wanted to make modifications to the original source code. While this is a common use case for the pattern, there are many other motivations for designing things using sidecars. One of the other main advantages of using the sidecar pattern is modularity and reuse of the components used as sidecars. In deploying any real-world, reliable application, there is functionality that you need for debugging or other management of the

application, such as giving a readout of all of the different processes using resources in the container, similar to the `top` command-line tool.

One approach to providing this introspection is to require that each developer implement an HTTP `/topz` interface that provides a readout of resource usage. To make this easier, you might implement this webhook as a language-specific plug-in that the developer could simply link into their application. But even if done this way, the developer would be forced to choose to link it in, and your organization would be forced to implement the interface for every language it wants to support. Unless done with extreme rigor, this approach is bound to lead to variations among languages as well as a lack of support for the functionality when using new languages.

Instead, this `topz` functionality can be deployed as a sidecar container that shares the process-ID (PID) namespace with the application container. This `topz` container can introspect all running processes and provide a consistent user interface. Moreover, you can use the orchestration system to automatically add this container to all applications deployed via the orchestration system to ensure that there is a consistent set of tools available for all applications running in your infrastructure.

Of course, as with any technical choice, there are trade-offs between this modular container-based pattern and rolling your own code into your application. The library-based approach is always going to be somewhat less tailored to the specifics of your application. This means that it may be less efficient in terms of performance, or that the API may require some

adaptation to fit into your environment. I would compare these trade-offs to the difference between buying off-the-rack clothing versus bespoke fashion. The bespoke fashion will always fit you better, but it will take longer to arrive and cost more to acquire. As with clothes, for most of us it makes sense to buy the more general-purpose solution when it comes to coding. Of course, if your application demands extremes in terms of performance, you can always choose the handwritten solution.

Hands On: Deploying the topz Container

To see the `topz` sidecar in action, you first need to deploy some other container to act as the application container. Choose an existing application that you are running and deploy it using Docker:

```
$ docker run -d <my-app-image>  
<container-hash-value>
```

After you run that image, you will receive the identifier for that specific container. It will look something like: `ccc82b85000...` If you don't have it, you can always look it up using the `docker ps` command, which will show all currently running containers. Assuming you have stashed that value in an environment variable named `APP_ID`, you can then run the `topz` container in the same PID namespace using:

```
$ docker run --pid=container:${APP_ID} \  
  -p 8080:8080 \  
  brendanburns/topz:db0fa58 \  
  /server --addr=0.0.0.0:8080
```

This will launch the `topz` sidecar in the same PID namespace as the application container. Note that you may need to change the port that the sidecar uses for serving if your application container is also running on port `8080`. Once the sidecar is running, you can visit <http://localhost:8080/topz> to get a complete readout of the processes that are running in the application container and their resource usage.

You can mix this sidecar with any other existing container to easily get a view into how the container is using its resources via a web interface.

Building a Simple PaaS with Sidecars

The sidecar pattern can be used for more than adaptation and monitoring. It can also be used as a means to implement the complete logic for your application in a simplified, modular manner. As an example, imagine building a simple platform as a service (PaaS) built around the `git` workflow. Once you deploy this PaaS, simply pushing new code up to a Git repository results in that code being deployed to the running servers. We'll

see how the sidecar pattern makes building this PaaS remarkably straightforward.

As previously stated, in the sidecar pattern there are two containers: the main application container and the sidecar. In our simple PaaS application, the main container is a Node.js server that implements a web server. The Node.js server is instrumented so that it automatically reloads the server when new files are updated. This is accomplished with the [nodemon tool](#).

The sidecar container shares a filesystem with the main application container and runs a simple loop that synchronizes the filesystem with an existing Git repository:

```
#!/bin/bash

while true; do
  git pull
  sleep 10
done
```

Obviously, this script could be more complex, pulling from a specific branch instead of simply from HEAD. It is left purposefully simple to improve the readability of this example.

The Node.js application and Git synchronization sidecar are coscheduled and deployed together to implement our simple PaaS ([Figure 3-4](#)). Once

deployed, every time new code is pushed to a Git repository, the code is automatically updated by the sidecar and reloaded by the server.

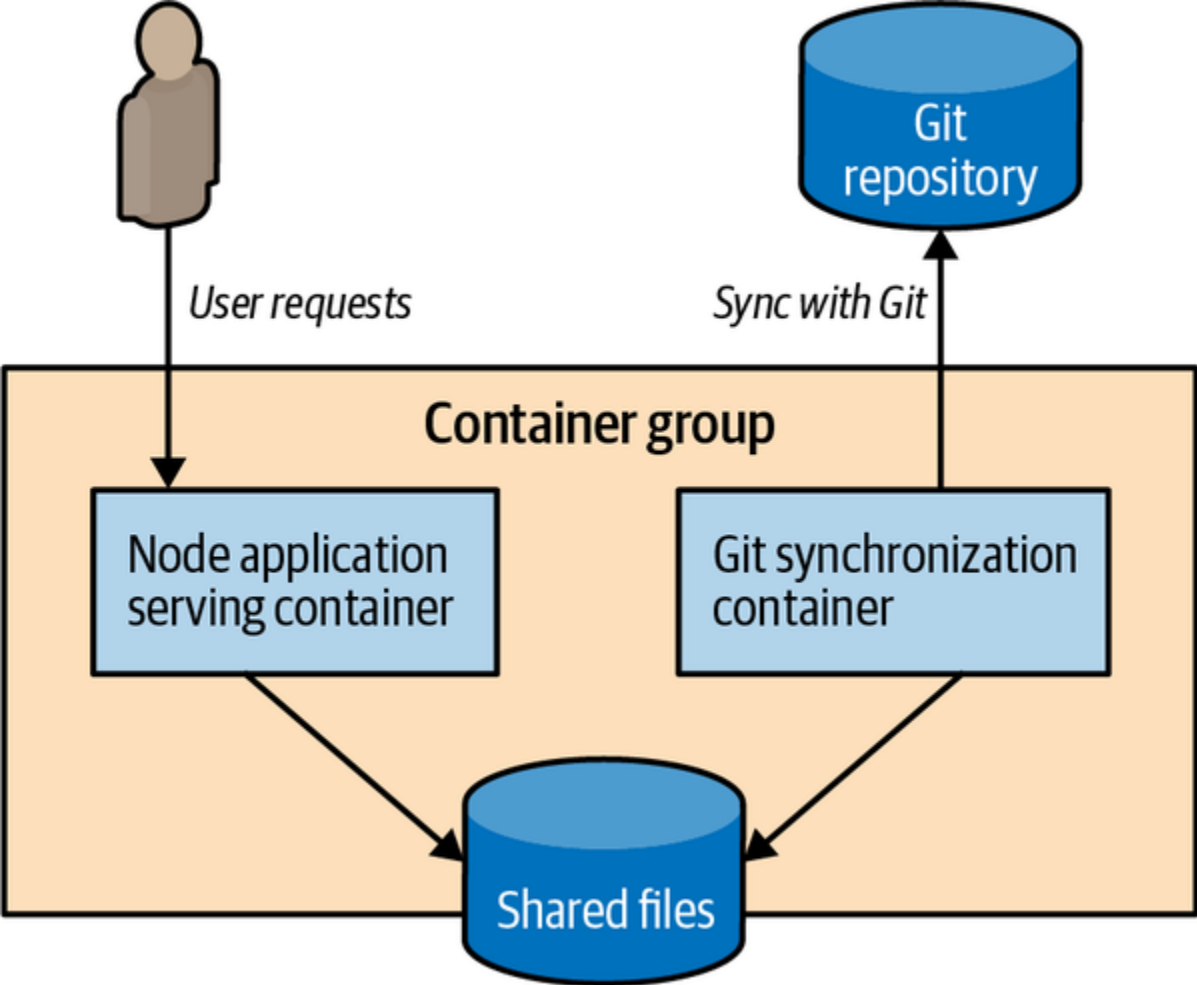

Figure 3-4. A simple sidecar-based PaaS

Designing Sidecars for Modularity and Reusability

In all of the examples of sidecars that we have detailed throughout this chapter, one of the most important themes is that every one was a modular, reusable artifact. To be successful, the sidecar should be reusable across a wide variety of applications and deployments. By achieving modular reuse, sidecars can dramatically speed up the building of your application.

However, this modularity and reusability, just like achieving modularity in high-quality software development, requires focus and discipline. In particular, you need to focus on developing three areas:

- Parameterizing your containers
- Creating the API surface of your container
- Documenting the operation of your container

Once you follow these common approaches, you will develop sidecars that can be re-used across a wide variety of applications.

Parameterized Containers

Parameterizing your containers is the most important thing you can do to make your containers modular and reusable regardless of whether they are sidecars or not, though sidecars and other add-on containers are especially important to parameterize.

What do I mean when I say “parameterize”? Consider your container as a function in your program. How many parameters does it have? Each

parameter represents an input that can customize a generic container to a specific situation. Consider, for example, the SSL add-on sidecar deployed previously. To be generally useful, it likely needs at least two parameters: the first is the name of the certificate being used to provide SSL, and the other is the port of the “legacy” application server running on localhost. Without these parameters, it is hard to imagine this sidecar container being usable for a broad array of applications. Similar parameters exist for all of the other sidecars described in this chapter.

Now that we know the parameters we want to expose, how do we actually expose them to users, and how do we consume them inside the container. There are two ways in which such parameters can be passed to your container: through environment variables or the command line. Though either is feasible, I have a general preference for passing parameters via environment variables. An example of passing such parameters to a sidecar container is:

```
docker run -e=PORT=<port> -d <image>
```

Of course, delivering values into the container is only part of the battle. The other part is actually using these variables inside the container. Typically, to do that, a simple shell script is used that loads the environment variables supplied with the sidecar container and either adjusts the configuration files or parameterizes the underlying application.

For example, you might pass in the certificate path and port as environment variables:

```
docker run -e=PROXY_PORT=8080 -e=CERTIFICATE_PATH
```

In your container, you would use those variables to configure an `nginx.conf` file that points the web server to the correct file and proxy location.

Define Each Container's API

Given that you are parameterizing your containers, it is obvious that your containers are defining a “function” that is called whenever the container is executed. This function is clearly a part of the API that is defined by your container, but there are other parts to this API as well, including calls that the container will make to other services as well as traditional HTTP or other APIs that the container provides.

As you think about defining modular, reusable containers, it is important to realize that all aspects of how your container interacts with its world are part of the API defined by that reusable container. As in the world of microservices, these *microcontainers* rely on APIs to ensure that there is a clean separation between the main application container and the sidecar. Additionally, the API exists to ensure that all consumers of the sidecar will

continue to work correctly as subsequent versions are released. Likewise, having a clean API for a sidecar enables the sidecar developer to move more quickly since they have a clear definition (and hopefully unit tests) for the services they provide as a part of the sidecar.

To see a concrete example of why this API surface area is important, consider the configuration management sidecar we discussed earlier. A useful configuration for this sidecar might be `UPDATE_FREQUENCY`, which indicates how often the configuration should be synchronized with the filesystem. It is clear that if, at some later time, the name of the parameter is changed to `UPDATE_PERIOD`, this change would be a violation of the sidecar's API and clearly would break it for some users.

While that example is obvious, even more subtle changes can break the sidecar API. Imagine, for example, that `UPDATE_FREQUENCY` originally took a number in seconds. Over time and with feedback from users, the sidecar developer determined that specifying seconds for large time values (e.g., minutes) was annoying users and changed the parameter to accept strings (10 m, 5 s, etc.). Because old parameter values (e.g., 10, for 10 seconds) won't parse in this new scheme, this is a breaking API change. Suppose still that the developer anticipated this but made values without units parse to milliseconds where they had previously parsed to seconds. Even this change, despite not leading to an error, is a breaking API change for the sidecar since it will lead to significantly more frequent configuration checks and correspondingly more load on the cloud configuration server.

I hope this discussion has shown you that for true modularity, you need to be very conscious of the API that your sidecar provides, and that “breaking” changes to that API may not always be as obvious as changing the name of a parameter.

Documenting Your Containers

By now, you’ve seen how you can parameterize your sidecar containers to make them modular and reusable. You’ve learned about the importance of maintaining a stable API to ensure that you don’t break sidecars for your users. But there’s one final step to building modular, reusable containers: ensuring that people can use them in the first place.

As with software libraries, the key to building something truly useful is explaining how to use it. There is little good in building a flexible, reliable modular container if no one can figure out how to use it. Sadly, there are few formal tools available for documenting container images, but there are some best practices you can use to accomplish this.

For every container image, the most obvious place to look for documentation is the `Dockerfile` from which the container was built. There are some parts of the `Dockerfile` that already document how the container works. One example of this is the `EXPOSE` directive, which indicates the ports that the image listens on. Even though `EXPOSE` is not necessary, it is a good practice to include it in your `Dockerfile` and

also to add a comment that explains what exactly is listening on that port.
For example:

```
...  
  
# Main web server runs on port 8080  
EXPOSE 8080  
  
...
```

Additionally, if you use environment variables to parameterize your container, you can use the `ENV` directive to set default values for those parameters as well as document their usage:

```
...  
  
# The PROXY_PORT parameter indicates the port on  
# traffic to.  
  
ENV PROXY_PORT 8000  
  
...
```

Finally, you should always use the `LABEL` directive to add metadata for your image; for example, the maintainer's email address, web page, and version of the image:

```
...  
LABEL "org.opencontainers.image.vendor"="name@corp.com"  
LABEL "org.opencontainers.image.url"="http://image.com"  
LABEL "org.opencontainers.image.version"="1.0.3"  
...
```

The names for these labels are drawn from the schema established by the [Open Containers Initiative](#). The Open Containers Initiative (OCI) is the specification body which maintains the definition of what it means to be a container image. A part of that specification is the definition of a shared set of annotations/labels. By using a common taxonomy of image labels, multiple different tools can rely on the same meta information in order to visualize, monitor, and correctly use an application. By adopting shared terms, you can use the set of tools developed in the community without modifying your image. Of course, you can also add whatever additional labels make sense in the context of your image.

Summary

Over the course of this chapter, we've introduced the sidecar pattern for combining containers on a single machine. In the sidecar pattern, a sidecar container augments and extends an application container to add functionality. Sidecars can be used to update existing legacy applications

when changing the application is too costly. Likewise, they can be used to create modular utility containers that standardize implementations of common functionality. These utility containers can be reused in a large number of applications, increasing consistency and reducing the cost of developing each application. Subsequent chapters introduce other single-node patterns that demonstrate other uses for modular, reusable containers.

Chapter 4. Ambassadors

[Chapter 3](#) introduced the sidecar pattern, where one container augments a pre-existing container to add functionality. This chapter introduces the ambassador pattern, where an ambassador container brokers interactions between the application container and the rest of the world. As with other single-node patterns, the two containers are tightly linked in a symbiotic pairing that is scheduled to a single machine. A canonical diagram of this pattern is shown in [Figure 4-1](#).

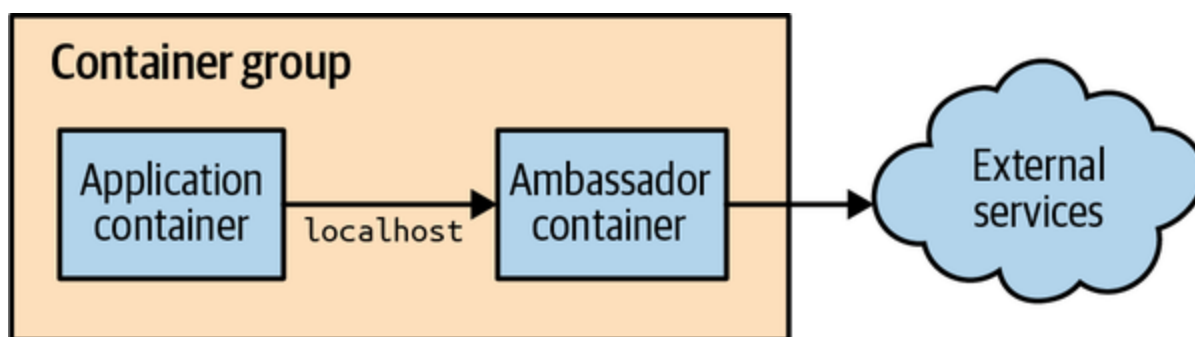

Figure 4-1. Generic ambassador pattern

The value of the ambassador pattern is twofold. First, as with the other single-node patterns, there is inherent value in building modular, reusable containers. The separation of concerns makes the containers easier to build and maintain. Likewise, the ambassador container can be reused with a number of different application containers. This reuse speeds up application development because the container's code can be reused in a number of

places. Additionally, the implementation is both more consistent and of a higher quality because it is built once and used in many different contexts.

The rest of this chapter provides a number of examples of using the ambassador pattern to implement a series of real-world applications.

Using an Ambassador to Shard a Service

Sometimes the data that you want to store in a storage layer becomes too big for a single machine to handle. In such situations, you need to *shard* your storage layer. Sharding splits up the layer into multiple disjoint pieces, each hosted by a separate machine. This chapter focuses on a single-node pattern for adapting an existing service to talk to a sharded service that exists somewhere in the world. It does not discuss how the sharded service came to exist. Sharding and a multinode sharded service design pattern are discussed in great detail in [Chapter 7](#). A diagram of a sharded service is shown in [Figure 4-2](#).

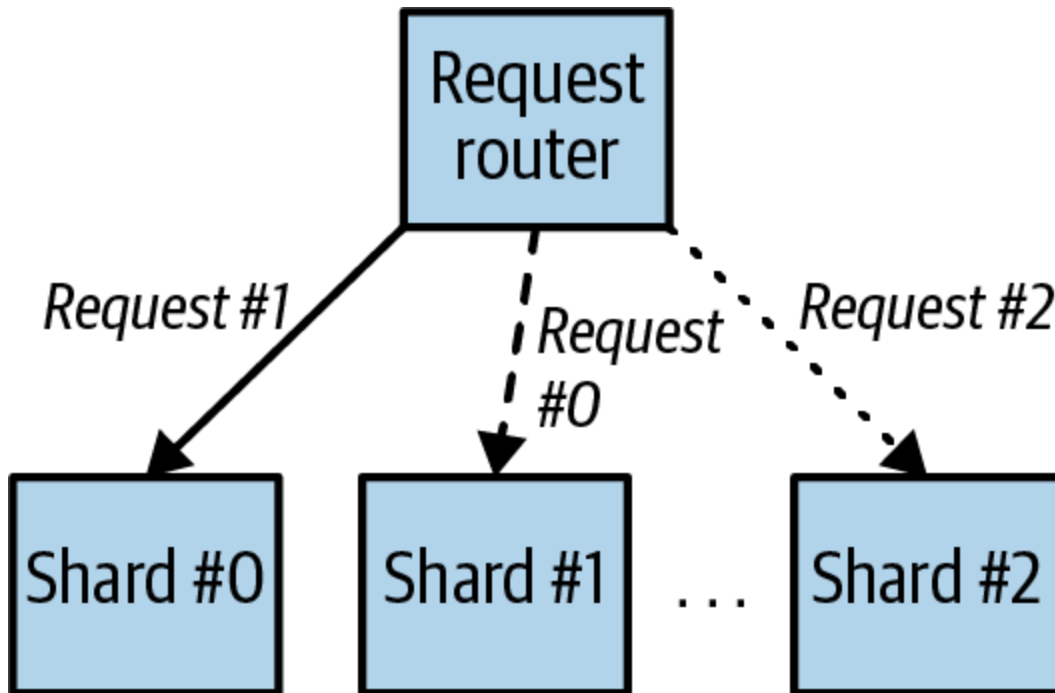

Figure 4-2. A generic sharded service

When deploying a sharded service, one question that arises is how to integrate it with the frontend or middleware code that stores data. Clearly there needs to be logic that routes a particular request to a particular shard, but often it is difficult to retrofit such a sharded client into existing source code that expects to connect to a single storage backend. Additionally, sharded services make it difficult to share configuration between development environments (where there is often only a single storage shard) and production environments (where there are often many storage shards).

One approach is to build all of the sharding logic into the sharded service itself. In this approach, the sharded service also has a stateless load balancer that directs traffic to the appropriate shard. Effectively, this load balancer is

a distributed ambassador as a service. This makes a client-side ambassador unnecessary at the expense of a more complicated deployment for the sharded service. The alternative is to integrate a single-node ambassador on the client side to route traffic to the appropriate shard. This makes deploying the client somewhat more complicated but simplifies the deployment of the sharded service. As is always the case with trade-offs, it is up to the particulars of your specific application to determine which approach makes the most sense. Some factors to consider include where team lines fall in your architecture, as well as where you are writing code versus simply deploying off-the-shelf software. Ultimately, either choice is valid. The section [“Hands On: Implementing a Sharded Redis”](#) describes how to use the single-node ambassador pattern for client-side sharding.

When adapting an existing application to a sharded backend, you can introduce an ambassador container that contains all of the logic needed to route requests to the appropriate storage shard. Thus, your frontend or middleware application only connects to what appears to be a single storage backend running on localhost. However, this server is in fact actually a *sharding ambassador proxy*, which receives all of the requests from your application code, sends a request to the appropriate storage shard, and then returns the result to your application. This use of an ambassador is diagrammed in [Figure 4-3](#).

The net result of applying the ambassador pattern to sharded services is a separation of concerns between the application container, which simply

knows it needs to talk to a storage service and discovers that service on localhost, and the sharding ambassador proxy, which only contains the code necessary to perform appropriate sharding. As with all good single-node patterns, this ambassador can be reused between many different applications. Or, as we'll see in the following hands-on example, an off-the-shelf open source implementation can be used for the ambassador, speeding up the development of the overall distributed system.

Hands On: Implementing a Sharded Redis

Redis is a fast key-value store that can be used as a cache or for more persistent storage. In this example, we'll be using it as a cache. We'll begin by deploying a sharded Redis service to a Kubernetes cluster. We'll use the `StatefulSet` API object to deploy it, since it will give us unique DNS names for each shard that we can use when configuring the proxy.

The `StatefulSet` for Redis looks like this:

```
apiVersion: apps/v1beta1
kind: StatefulSet
metadata:
  name: sharded-redis
spec:
  serviceName: "redis"
  replicas: 3
  template:
```

```
metadata:
  labels:
    app: redis
spec:
  terminationGracePeriodSeconds: 10
  containers:
  - name: redis
    image: redis
    ports:
    - containerPort: 6379
      name: redis
```

Save this to a file named *redis-shards.yaml*, and you can deploy this with `kubectl create -f redis-shards.yaml`. This will create three containers running redis. You can see these by running `kubectl get pods`; you should see `sharded-redis-[0,1,2]`.

Of course, just running the replicas isn't sufficient; we also need names by which we can refer to the replicas. In this case, we'll use a Kubernetes `Service`, which will create DNS names for the replicas we have created. The `Service` looks like this:

```
apiVersion: v1
kind: Service
metadata:
  name: redis
  labels:
```

```
    app: redis
spec:
  ports:
  - port: 6379
    name: redis
  clusterIP: None
  selector:
    app: redis
```

Save this to a file named *redis-service.yaml* and deploy with `kubectl create -f redis-service.yaml`. You should now have DNS entries for `sharded-redis-0.redis`, `sharded-redis-1.redis`, etc. We can use these names to configure `twemproxy`. `twemproxy` is a lightweight, highly performant proxy for `memcached` and `Redis`, which was originally developed by Twitter and is open source and available on [GitHub](#). We can configure `twemproxy` to point to the replicas we created by using the following configuration:

```
redis:
  listen: 127.0.0.1:6379
  hash: fnv1a_64
  distribution: ketama
  auto_eject_hosts: true
  redis: true
  timeout: 400
  server_retry_timeout: 2000
```

```
server_failure_limit: 1
servers:
  - sharded-redis-0.redis:6379:1
  - sharded-redis-1.redis:6379:1
  - sharded-redis-2.redis:6379:1
```

In this config, you can see that we are serving the Redis protocol on `localhost:6379` so that the application container can access the ambassador. We will deploy this into our ambassador pod using a Kubernetes `ConfigMap` object that we can create with:

```
kubectl create configmap twem-config --from-file=
```

Finally, all of the preparations are done and we can deploy our ambassador example. We define a pod that looks like:

```
apiVersion: v1
kind: Pod
metadata:
  name: ambassador-example
spec:
  containers:
    # This is where the application container would go
    # - name: nginx
```

```
# image: nginx
# This is the ambassador container
- name: twemproxy
  image: ganomede/twemproxy
  command:
    - "nutcracker"
    - "-c"
    - "/etc/config/nutcracker.yaml"
    - "-v"
    - "7"
    - "-s"
    - "6222"
  volumeMounts:
    - name: config-volume
      mountPath: /etc/config
volumes:
  - name: config-volume
    configMap:
      name: twem-config
```

This pod defines the ambassador; then the specific user's application container can be injected to complete the pod.

Using an Ambassador for Service Brokering

When trying to render an application portable across multiple environments (e.g., public cloud, physical data center, or private cloud), one of the primary challenges is service discovery and configuration. To understand what this means, imagine a frontend that relies on a MySQL database to store its data. In the public cloud, this MySQL service might be provided as software as a service (SaaS), whereas in a private cloud it might be necessary to dynamically spin up a new virtual machine or container running MySQL.

Consequently, building a portable application requires that the application know how to introspect its environment and find the appropriate MySQL service to connect to. This process is called *service discovery*, and the system that performs this discovery and linking is commonly called a *service broker*. As with previous examples, the ambassador pattern enables a system to separate the logic of the application container from the logic of the service broker ambassador. The application simply always connects to an instance of the service (e.g., MySQL) running on localhost. It is the responsibility of the service broker ambassador to introspect its environment and broker the appropriate connection. This process is shown in [Figure 4-3](#).

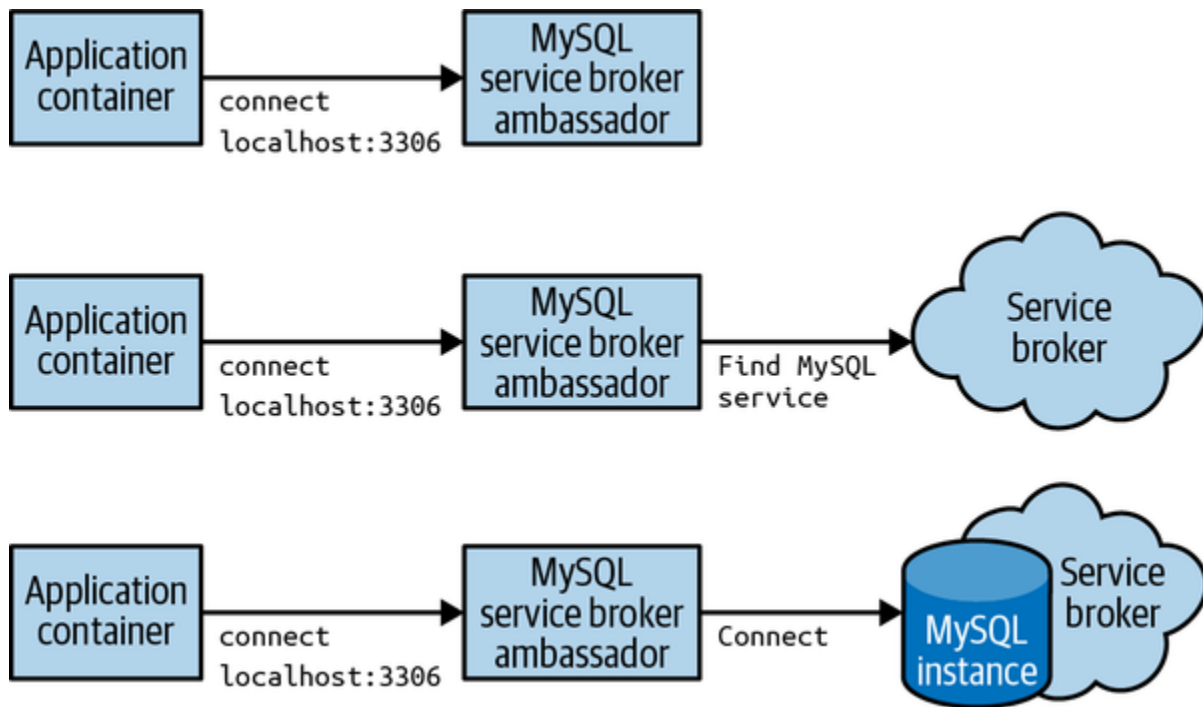

Figure 4-3. A service broker ambassador creating a MySQL service

Using an Ambassador to Do Experimentation or Request Splitting

A final example application of the ambassador pattern is to perform experimentation or other forms of request splitting. In many production systems, it is advantageous to be able to perform request splitting, where some fraction of all requests are not serviced by the main production service but rather are redirected to a different implementation of the service. Most often, this is used to perform experiments with new beta versions of the service to determine if the new version of the software is reliable or comparable in performance to the currently deployed version.

Additionally, request splitting is sometimes used to `tee` or split traffic such that all traffic goes to both the production system as well as a newer, undeployed version. The responses from the production system are returned to the user, while the responses from the `tee-d` service are ignored. Most often, this form of request splitting is used to simulate production load on the new version of the service without risking impact to existing production users.

Given the previous examples, it is straightforward to see how a request-splitting ambassador can interact with an application container to implement request splitting. As before, the application container simply connects to the service on localhost, while the ambassador container receives the requests, proxies responses to both the production and experimental systems, and then returns the production responses back as if it had performed the work itself.

This separation of concerns keeps the code in each container slim and focused, and the modular factoring of the application ensures that the request-splitting ambassador can be reused for a variety of different applications and settings.

Hands On: Implementing 10% Experiments

To implement our request-splitting experiment, we're going to use the `nginx` web server. `nginx` is a powerful, richly featured open source

server. To configure `nginx` as the ambassador, we'll use the following configuration (note that this is for HTTP but it could easily be adapted for HTTPS as well):

```
worker_processes 5;
error_log error.log;
pid nginx.pid;
worker_rlimit_nofile 8192;

events {
    worker_connections 1024;
}

http {
    upstream backend {
        ip_hash;
        server web weight=9;
        server experiment;
    }

    server {
        listen localhost:80;
        location / {
            proxy_pass http://backend;
        }
    }
}
```

NOTE

As with the previous discussion of sharded services, it's also possible to deploy the experiment framework as a separate microservice in front of your application instead of integrating it as a part of your client pods. Of course, by doing this you are introducing another service that needs to be maintained, scaled, monitored, etc. If experimentation is likely to be a longstanding component in your architecture, this might be worthwhile. If it is used more occasionally, then a client-side ambassador might make more sense.

You'll note that I'm using IP hashing in this configuration. This is important because it ensures that the user doesn't flip-flop back and forth between the experiment and the main site. This assures that every user has a consistent experience with the application.

The `weight` parameter is used to send 90% of the traffic to the main existing application, while 10% of the traffic is redirected to the experiment.

As with other examples, we'll deploy this configuration as a `ConfigMap` object in Kubernetes:

```
kubectl create configmap experiment-config --from
```

Of course, this assumes that you have both a `web` and `experiment` service defined. If you don't, you need to create them now before you try to create the ambassador container, since `nginx` doesn't like to start if it

can't find the services it is proxying to. Here are some example service configs:

```
# This is the 'experiment' service
apiVersion: v1
kind: Service
metadata:
  name: experiment
  labels:
    app: experiment
spec:
  ports:
    - port: 80
      name: web
  selector:
    # Change this selector to match your application
    app: experiment
---
# This is the 'prod' service

apiVersion: v1
kind: Service
metadata:
  name: web
  labels:
    app: web
spec:
  ports:
    - port: 80
```

```
    port: 80
    name: web
  selector:
    # Change this selector to match your application
    app: web
```

And then we will deploy `nginx` itself as the ambassador container within a pod:

```
  apiVersion: v1
  kind: Pod
  metadata:
    name: experiment-example
  spec:
    containers:
      # This is where the application container would go
      # - name: some-name
      #   image: some-image
      # This is the ambassador container
      - name: nginx
        image: nginx
        volumeMounts:
          - name: config-volume
            mountPath: /etc/nginx
    volumes:
      - name: config-volume
        configMap:
          name: experiment-config
```

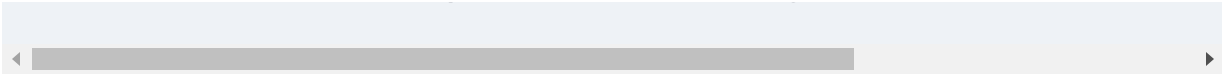

You can add a second (or third, or fourth) container to the pod to take advantage of the ambassador.

Summary

Ambassadors are a key way to simplify life for application developers. They can encapsulate complex logic that is necessary for scale or reliability, such as sharding, and provide a simplified interface which makes such a complex system easy to use. For platform engineers, ambassadors can be an important tool in constructing a powerful platform that is easy to use.

Chapter 5. Adapters

In the preceding chapters, we saw how the sidecar pattern can extend and augment existing application containers. We also saw how ambassadors can alter and broker how an application container communicates with the external world. This chapter describes the final single-node pattern: the *adapter* pattern. In the adapter pattern, the *adapter container* is used to modify the interface of the *application container* so that it conforms to some predefined interface that is expected of all applications. For example, an adapter might ensure that an application implements a consistent monitoring interface. Or it might ensure that log files are always written to `stdout` or any number of other conventions.

Real-world application development is a heterogeneous, hybrid exercise. Some parts of your application might be written from scratch by your team, some supplied by vendors, and some might consist entirely of off-the-shelf open source or proprietary software that you consume as precompiled binary. The net effect of this heterogeneity is that any real-world application you deploy will have been written in a variety of languages, with a variety of conventions for logging, monitoring, and other common services.

Yet, to effectively monitor and operate your application, you need common interfaces. When each application provides metrics using a different format and interface, it is very difficult to collect all of those metrics in a single

place for visualization and alerting. This is where the adapter pattern is relevant. Like other single-node patterns, the adapter pattern is made up of modular containers. Different application containers can present many different monitoring interfaces while the adapter container adapts this heterogeneity to present a consistent interface. This enables you to deploy a single tool that expects this single interface. [Figure 5-1](#) illustrates this general pattern.

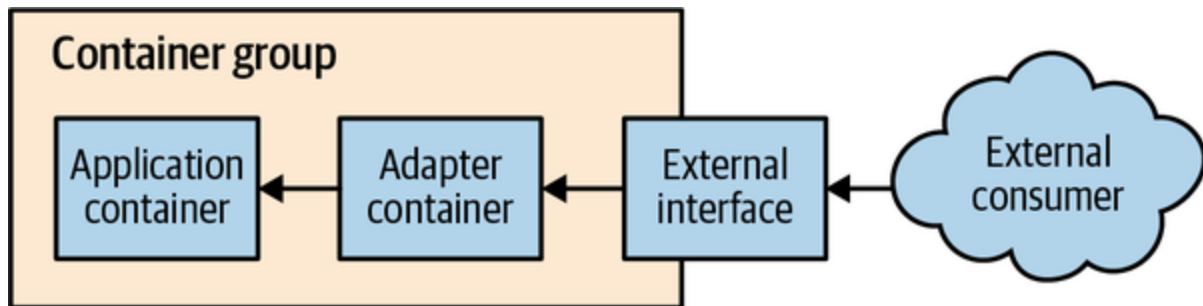

Figure 5-1. The generic adapter pattern

The remainder of this chapter gives several different applications of the adapter pattern.

Monitoring

When monitoring your software, you want a single solution that can automatically discover and monitor any application that is deployed into your environment. To make this feasible, every application has to implement the same monitoring interface. There are numerous examples of standardized monitoring interfaces, such as `syslog`, Event Tracing for

Windows (ETW), JMX for Java applications, and many, many other protocols and interfaces. However, each of these is unique in both protocol for communication as well as the style of communication (push versus pull).

Sadly, applications in your distributed system are likely to span the gamut from code that you have written yourself to off-the-shelf open source components. As a result, you will find yourself with a wide range of different monitoring interfaces that you need to integrate into a single well-understood system.

Fortunately, most monitoring solutions understand that they need to be widely applicable, and thus they have implemented a variety of plug-ins that can adapt one monitoring format to a common interface. Given this set of tools, how can we deploy and manage our applications in an agile and stable manner? Fortunately, the adapter pattern can provide us with the answers. Applying the adapter pattern to monitoring, we see that the application container is simply the application that we want to monitor. The adapter container contains the tools for transforming the monitoring interface exposed by the application container into the interface expected by the general-purpose monitoring system.

Decoupling the system in this fashion makes for a more comprehensible, maintainable system. Rolling out new versions of the application doesn't require a rollout of the monitoring adapter. Additionally, the monitoring

container can be reused with multiple different application containers. The monitoring container may even have been supplied by the monitoring system maintainers independent of the application developers. Finally, deploying the monitoring adapter as a separate container ensures that each container gets its own dedicated resources in terms of both CPU and memory. This ensures that a misbehaving monitoring adapter cannot cause problems with a user-facing service.

Hands On: Using Prometheus for Monitoring

As an example, consider monitoring your containers via the [Prometheus open source project](#). Prometheus is a monitoring aggregator, which collects metrics and aggregates them into a single time-series database. On top of this database, Prometheus provides visualization and query language for introspecting the collected metrics. To collect metrics from a variety of different systems, Prometheus expects every container to expose a specific `metrics` API. This enables Prometheus to monitor a wide variety of different programs through a single interface.

However, many popular programs, such as the Redis key-value store, do not export metrics in a format that is compatible with Prometheus.

Consequently, the adapter pattern is quite useful for taking an existing service like Redis and adapting it to the Prometheus metrics-collection interface.

Consider a simple Kubernetes pod definition for a Redis server:

```
apiVersion: v1
kind: Pod
metadata:
  name: adapter-example
  namespace: default
spec:
  containers:
  - image: redis
    name: redis
```

At this point, this container is not capable of being monitored by Prometheus because it does not export the right interface. However, if we simply add an adapter container (in this case, an open source Prometheus exporter), we can modify this pod to export the correct interface and thus adapt it to fit Prometheus's expectations:

```
apiVersion: v1
kind: Pod
metadata:
  name: adapter-example
  namespace: default
spec:
  containers:
  - image: redis
    name: redis
```

```
# Provide an adapter that implements the Prometheus adapter
- image: oliver006/redis_exporter
  name: adapter
```

This example illustrates not only the value of the adapter pattern for ensuring a consistent interface, but also the value of container patterns in general for modular container reuse. In this case, the example shown combines an existing Redis container with an existing Prometheus adapter. The net effect is a monitorable Redis server, with little work on our part to deploy it. In the absence of the adapter pattern, the same deployment would have required significantly more custom work and would have resulted in a much less operable solution, since any updates to either Redis or the adapter would have required work to apply the update.

Logging

Much like monitoring, there is a wide variety of heterogeneity in how systems log data to an output stream. Systems might divide their logs into different levels (such as debug, info, warning, and error) with each level going into a different file. Some might simply log to `stdout` and `stderr`. This is especially problematic in the world of containerized applications, where there is a general expectation that your containers will log to `stdout`, because that is what is available via commands like `docker logs` or `kubectl logs`.

Adding further complexity, the information logged generally has structured information (e.g., the date/time of the log), but this information varies widely between different logging libraries (e.g., Java's built-in logging versus the `glog` package for Go).

Of course, when you are storing and querying the logs for your distributed system, you don't really care about these differences in logging format. You want to ensure that despite different structures for the data, every log ends up with the appropriate timestamp.

Fortunately, as with monitoring, the adapter pattern can help provide a modular, re-usable design for both of these situations. While the application container may log to a file, the adapter container can redirect that file to `stdout`. Different application containers can log information in different formats, but the adapter container can transform that data into a single structured representation that can be consumed by your log aggregator. Again, the adapter is taking a heterogeneous world of applications and creating a homogenous world of common interfaces.

NOTE

One question that often comes up when considering adapter patterns is: why not simply modify the application container itself? If you are the developer responsible for the application container, then this might actually be a good solution. Adapting your code or your container to implement a consistent interface can work well. However, in many cases we are reusing a container produced by another party. In such cases, deriving a slightly modified image that we have to maintain (patch, rebase, etc.) is significantly more expensive than developing an adapter container that can run alongside the other party's image. Additionally, decoupling the adapter into its own container allows for the possibility of sharing and reuse, which isn't possible when you modify the application container.

Hands On: Normalizing Different Logging Formats with `fluentd`

One common task for an adapter is to normalize log metrics into a standard set of events. Many different applications have different output formats, but you can use a standard logging tool deployed as an adapter to normalize them all to a consistent format. In this example, we will use the `fluentd` monitoring agent as well as some community-supported plug-ins to obtain logs from a variety of different sources.

`fluentd` is one of the more popular open source logging agents available. One of its major features is a rich set of community-supported plug-ins that enable a great deal of flexibility in monitoring a variety of applications.

The first application that we will monitor is Redis. Redis is a popular key-value store; one of the commands it offers is the `SLOWLOG` command. This command lists recent queries that exceeded a particular time interval. Such information is quite useful in debugging your application's performance. Unfortunately, `SLOWLOG` is only available as a command on the Redis server, which means that it is difficult to use retrospectively if a problem happens when someone isn't available to debug the server. To fix this limitation, we can use `fluentd` and the adapter pattern to add slow-query logging to Redis.

To do this, we use the adapter pattern with a `redis` container as the main application container, and the `fluentd` container as our adapter container. In this case, we will also use the [`fluent-plugin-redis-slowlog`](#) `fluentd` plug-in to listen to the slow queries. We can configure this plug-in by using the following snippet:

```
<source>
  type redis_slowlog
  host localhost
  port 6379
  tag redis.slowlog
</source>
```

Because we are using an adapter and the containers both share a network namespace, configuring the logging simply uses `localhost` and the

default Redis port (6379). Given this application of the adapter pattern, logging will always be available whenever we want to debug slow Redis queries.

A similar exercise can be done to monitor logs from the [Apache Storm system](#). Again, Storm provides data via a RESTful API, which is useful but has limitations if we are not currently monitoring the system when a problem occurs. Like Redis, we can use a `fluentd` adapter to transform the Storm process into a time series of queryable logs. To do this, we deploy a `fluentd` adapter with the `fluent-plugin-storm` plug-in enabled. We can configure this plug-in with a `fluentd` config pointed at localhost (because again, we are running as a container group with a shared localhost); the config for the plug-in looks like:

```
<source>
  type storm
  tag storm
  url http://localhost:8080
  window 600
  sys 0
</source>
```

This adapter builds a bridge between Storm and the time series of logs.

Adding a Health Monitor

One last example of applying the adapter pattern is derived from monitoring the health of an application container. Consider the task of monitoring the health of an off-the-shelf database container. In this case, the container for the database is supplied by the database project, and we would rather not modify that container simply to add health checks. Of course, a container orchestrator will allow us to add simple health checks to ensure that the process is running and that it is listening on a particular port, but what if we want to add richer health checks that actually run queries against the database?

Container orchestration systems like Kubernetes enable us to use shell scripts as health checks as well. Given this capability, we can write a rich shell script that runs a number of different diagnostic queries against the database to determine its health. But where can we store such a script and how can we version it?

The answer to these problems should be easy to guess by now: we can use an adapter container. The database runs in the application container and shares a network interface with the adapter container. The adapter container is a simple container that only contains the shell script for determining the health of the database. This script can then be set up as the health check for the database container and can perform whatever rich health checks our application requires. If these checks ever fail, the database will be automatically restarted.

Hands On: Adding Rich Health Monitoring for MySQL

Suppose, then, that you want to add deep monitoring on a MySQL database where you actually run a query that is representative of your workload. In this case, one option would be to update the MySQL container to contain a health check that is specific to your application. However, this is generally an unattractive idea because it requires that you both modify some existing MySQL base image as well as update that image as new MySQL images are released.

Using the adapter pattern is a much more attractive approach to adding health checks to your database container. Instead of modifying the existing MySQL container, you can add an additional adapter container to the preexisting MySQL container, which runs the appropriate query to test the database health. Given that this adapter container implements the expected HTTP health check, it is simply a case of defining the MySQL database process's health check in terms of the interface exposed by this database adapter.

The source code for this adapter is relatively straightforward and looks like this in Go (though clearly other language implementations are possible as well):

```

package main

import (
    "database/sql"
    "flag"
    "fmt"
    "net/http"

    _ "github.com/go-sql-driver/mysql"
)

var (
    user    = flag.String("user", "", "The database user")
    passwd  = flag.String("password", "", "The database password")
    db      = flag.String("database", "", "The database name")
    query   = flag.String("query", "", "The SQL query to execute")
    addr    = flag.String("address", "localhost", "The address to listen on")
)

// Basic usage:
// db-check --query="SELECT * from my-cool-table"
//          --user=bdburns \
//          --passwd="you wish"
//
func main() {
    flag.Parse()
    db, err := sql.Open("mysql",

```

```

                                fmt.Sprintf("%s:%s@/%s
    if err != nil {
        fmt.Printf("Error opening database
    }

// Simple web handler that runs the query
    http.HandleFunc("", func(res http.Respons
        _, err := db.Exec(*query)
        if err != nil {
            res.WriteHeader(http.Stat
            res.Write([]byte(err.Error
            return
        }
        res.WriteHeader(http.StatusOK)
        res.Write([]byte("OK"))
        return
    })
// Startup the server
    http.ListenAndServe(*addr, nil)
}

```

We can then build this into a container image and pull it into a pod that looks like:

```

apiVersion: v1
kind: Pod
metadata:

```

```
name: adapter-example-health
namespace: default
spec:
  containers:
  - image: mysql
    name: mysql
  - image: brendanburns/mysql-adapter
    name: adapter
```

That way, the `mysql` container is unchanged, but the desired feedback about the health of the MySQL server can still be obtained from the adapter container.

When looking at this application of the adapter pattern, it may seem like applying the pattern is superfluous. Clearly we could have built our own custom image that knew how to health check the `mysql` instance itself.

While this is true, this method ignores the strong benefits that derive from modularity. If every developer implements their own specific container with health checking built in, there are no opportunities for reuse or sharing.

In contrast, if we use patterns like the adapter to develop modular solutions comprised of multiple containers, the work is inherently decoupled and more easily shared. An adapter that is developed to health check `mysql` is a module that can be shared and reused by a variety of people. Further, people can apply the adapter pattern using this shared health-checking

container, without having deep knowledge of how to health check a `mysql` database. Thus the modularity and adapter pattern serve not to just facilitate sharing, but also to empower people to take advantage of the knowledge of others.

Sometimes design patterns aren't just for the developers who apply them, but lead to the development of communities that can collaborate and share solutions between members of the community as well as the broader developer ecosystem.

Summary

Sometimes the world isn't perfectly aligned. The components that we need to use to build our systems can have different interfaces or different protocols for interactions like logging, monitoring, and RPCs. Adapters can be a critical tool to add consistency to our systems, enabling them to share a consistent protocol and way of connecting. Using an adapter is often significantly easier than trying to change the upstream project.

Part III. Serving Patterns

[Chapter 5](#) described patterns for grouping collections of containers that are scheduled on the same machine. These groups are tightly coupled, symbiotic systems. They depend on local, shared resources like disk, network interface, or inter-process communications. Such collections of containers are important patterns, but they are also building blocks for larger systems. Reliability, scalability, and separation of concerns dictate that real-world systems are built out of many different components, spread across multiple machines. In contrast to single-node patterns, the multinode distributed patterns are more loosely coupled. While the patterns dictate patterns of communication between the components, this communication is based on network calls. Furthermore, many calls are issued in parallel, and systems coordinate via loose synchronization rather than tight constraints.

Recently, the term *microservices* has become a common term for describing multinode distributed software architectures. Microservices describe a system built out of many different components running in different processes and communicating over defined APIs. Microservices stand in contrast to *monolithic* systems, which tend to place all of the functionality for a service within a single, tightly coordinated application. These two different architectural approaches are shown in Figures [III-1](#) and [III-2](#).

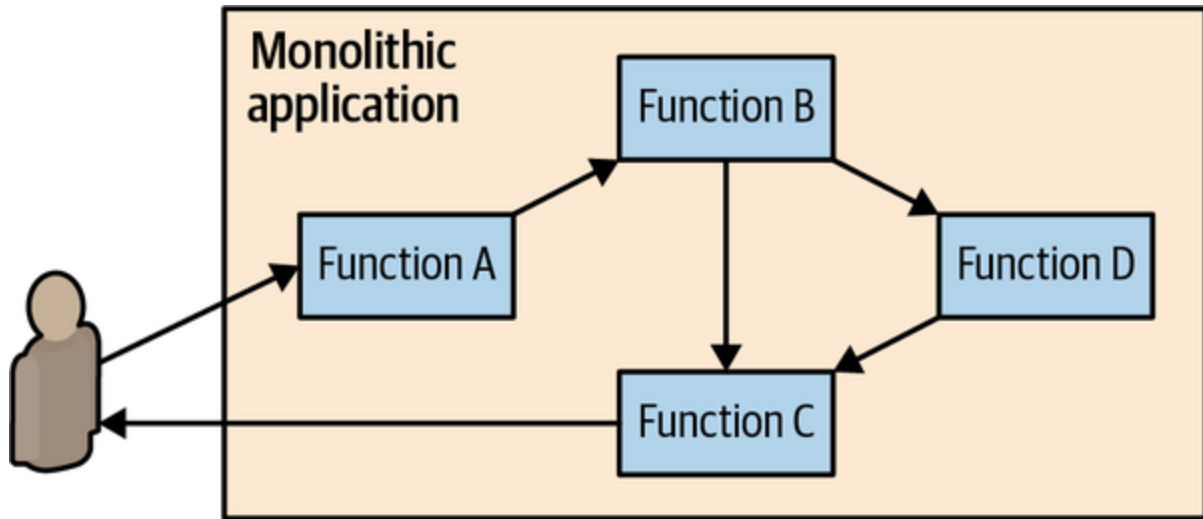

Figure III-1. A monolithic service with all functions in a single container

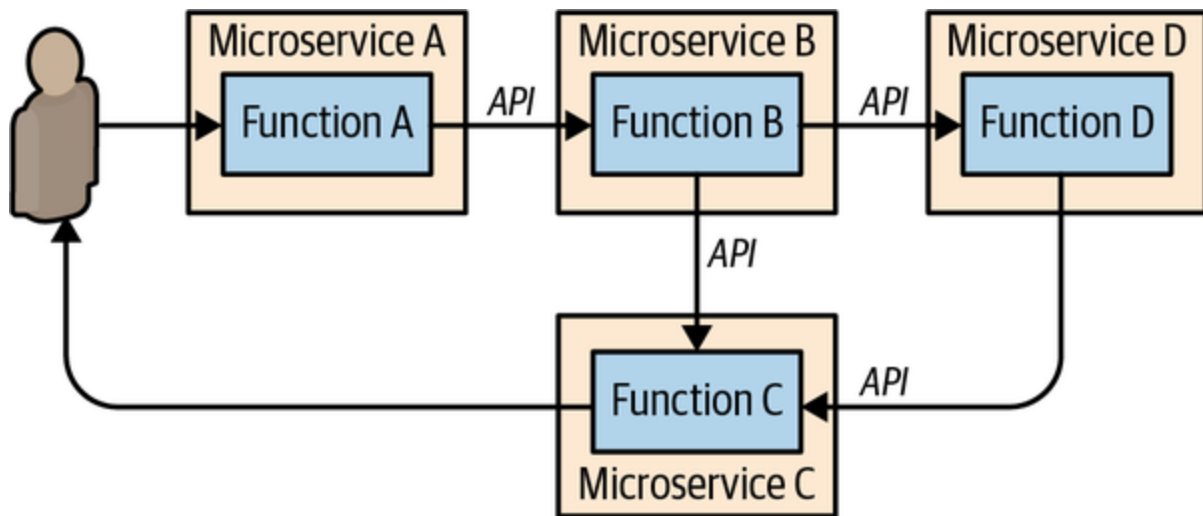

Figure III-2. A microservice architecture with each function broken out as a separate microservice

There are numerous benefits to the microservices approach—most of them are centered around reliability and agility. Microservices break down an application into small pieces, each focused on providing a single service. This reduced scope enables each service to be built and maintained by a single “two pizza” team. Reduced team size also reduces the overhead associated with keeping a team focused and moving in one direction.

Additionally, the introduction of formal APIs in between different microservices decouples the teams from one another and provides a reliable contract between the different services. This formal contract reduces the need for tight synchronization among the teams because the team providing the API understands the surface area that it needs to keep stable, and the team consuming the API can rely on a stable service without worrying about its details. This decoupling enables teams to independently manage their code and release schedules, which in turn improves each team's ability to iterate and improve their code.

The design of a service architecture is much like the design of a class hierarchy—its goals are to introduce abstraction, encapsulation, and modularity. It is important to note that in each of these categories the “right” design has as much to do with the humans involved in building the design as it does with the core application being developed.

Abstraction and encapsulation can often be seen as foils of each other. Abstraction enables teams to not worry about the details of how a complex piece of functionality is implemented and focus instead on what they can do with that capability. The programming required to recognize objects in an image using machine learning is quite complicated, but the abstract service `findObjectsInImage(image): objects` is quite easy to use. Distributed systems are quite complex, and trying to keep all of the details in our heads rapidly leads to information overload. Abstraction enables

teams to focus on higher-level capabilities, not lower-level implementation details.

Encapsulation is the same but in reverse; encapsulation allows teams to deliver a service while hiding the implementation details from the user. Hiding these details is critical because it enables the implementation team to make changes without breaking their users. This flexibility makes teams more agile because they are decoupled from each other. Taken together, encapsulation and abstraction enable us to build optimally sized teams for execution and delivery. Big enough to take on hard problems with a sense of purpose, but small enough to move quickly without the communication baggage that arises in larger teams.

Finally, the decoupling of microservices enables better scaling. Because each component has been broken out into its own service, it can be scaled independently. It is rare for each service within a larger application to grow at the same rate, or have the same way of scaling. Some systems are stateless and can simply scale horizontally, whereas other systems maintain state and require sharding or other approaches to scale. By separating each service out, each service can use the approach to scaling that suits it best. This is not possible when all services are part of a single monolith.

But of course there are downsides to the microservices approach to system design as well. As the system has become more loosely coupled, debugging the system when failures occur is significantly more difficult. You can no

longer simply load a single application into a debugger and determine what went wrong. Any errors are the by-products of a large number of systems often running on different machines. This environment is quite challenging to reproduce in a debugger. As a corollary, microservices-based systems are also difficult to design and architect. A microservices-based system uses multiple methods of communicating between services; different patterns (e.g., synchronous, asynchronous, message-passing, etc.); and multiple different patterns of coordination and control among the services.

Additionally, there can be a tendency within teams to take a microservice pattern to an extreme and end up with far too many microservices that are far too small. This over-segmentation not only adds complexity, but it also can add significant inefficiency in terms of both network overhead (since communication between microservices occurs on the network) and also costs (since each instance of a microservice has a fixed amount of overhead in terms of CPU and memory). As a general rule of thumb, if you have more microservices than you have engineers on your team, you either have a very small team or you are overdoing the microservice approach.

These challenges are the motivation for distributed patterns. If a microservices architecture is made up of well-known patterns, then it is easier to design because many of the design practices are specified by the patterns. Additionally, patterns make the systems easier to debug because they enable developers to apply lessons learned across a number of different systems that use the same patterns.

With that in mind, this section introduces a number of multinode patterns for building distributed systems. These patterns are not mutually exclusive. Any real-world system will be built from a collection of these patterns working together to produce a single higher-level application.

Chapter 6. Replicated Load-Balanced Services

The simplest distributed pattern, and one that most are familiar with, is a replicated load-balanced service. In such a service, every server is identical to every other server, and all are capable of supporting traffic from any client. The pattern consists of a scalable number of servers with a load balancer in front of them. The load balancer is typically either completely round-robin or uses some form of session stickiness. The chapter will give a concrete example of how to deploy such a service in Kubernetes.

Stateless Services

Stateless services are ones that don't require saved state to operate correctly. In the simplest stateless applications, even individual requests may be routed to separate instances of the service (see [Figure 6-1](#)). Examples of stateless services include things like static content servers and complex middleware systems that receive and aggregate responses from numerous different backend systems.

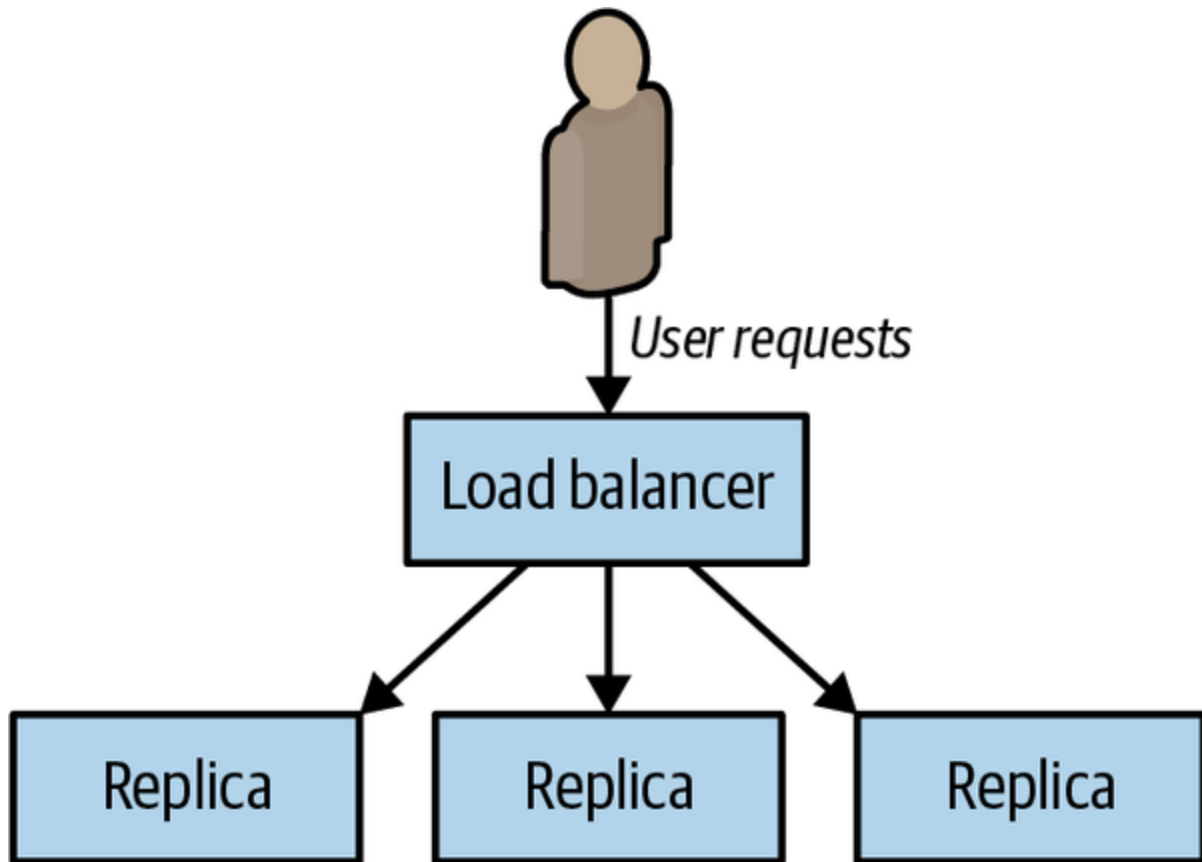

Figure 6-1. Basic replicated stateless service

Stateless systems are replicated to provide redundancy and scale. No matter how small your service is, you need at least two replicas to provide a service with a “highly available” service level agreement (SLA). To understand why this is true, consider trying to deliver a three-nines (99.9% availability). In a *three-nines service*, you get 1.4 minutes of downtime per day ($24 \times 60 \times 0.001$). Assuming that you have a service that never crashes, that still means you need to be able to do a software upgrade in less than 1.4 minutes in order to hit your SLA with a single instance. And that’s assuming that you do daily software rollouts. If your team is really embracing continuous delivery and you’re pushing a new version of

software every hour, you need to be able to do a software rollout in 3.6 seconds to achieve your 99.9% uptime SLA with a single instance. Any longer than that, and you will have more than 0.01% downtime from those 3.6 seconds. And all of this is assuming that your code never fails due to bugs, which is unrealistic in any real-world codebase.

Of course, instead of all of that work, you could just have two replicas of your service with a load balancer in front of them. That way, while you are doing a rollout, or in the—unlikely, I’m sure—event that your software crashes, your users will be served by the other replica of the service and never know anything was going on.

As services grow larger, they are also replicated to support additional users. *Horizontally scalable* systems handle more and more users by adding more replicas; see [Figure 6-2](#). They achieve this with the load-balanced replicated serving pattern.

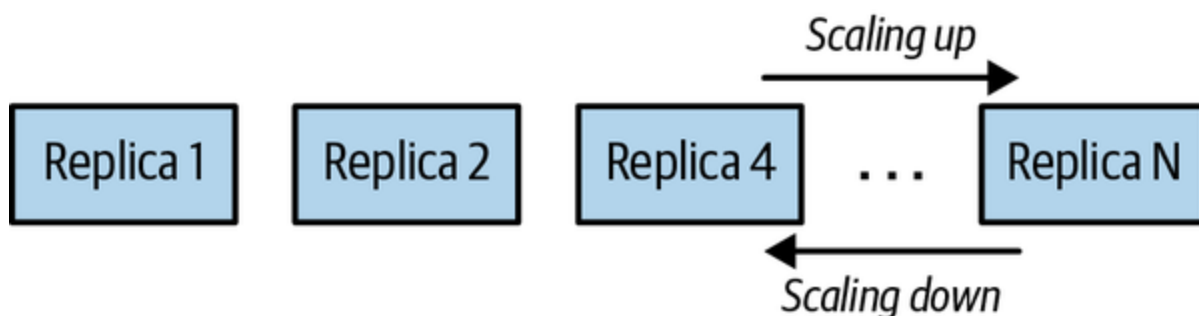

Figure 6-2. Horizontal scaling of a replicated stateless application

Readiness Probes for Load Balancing

Of course, simply replicating your service and adding a load balancer is only part of a complete pattern for stateless replicated serving. When designing a replicated service, it is equally important to build and deploy a readiness probe to inform the load balancer. We have discussed how health probes can be used by a container orchestration system to determine when an application needs to be restarted. In contrast, a *readiness probe* determines when an application is ready to serve user requests. The reason for the differentiation is that many applications require some time to become initialized before they are ready to serve. They may need to connect to databases, load plugins, or download serving files from the network. In all of these cases, the containers are *alive*, but they are not *ready*. When building an application for a replicated service pattern, be sure to include a special URL that implements this readiness check.

Hands On: Creating a Replicated Service in Kubernetes

The instructions below give a concrete example of how to deploy a stateless replicated service behind a load balancer. These directions use the Kubernetes container orchestrator, but the pattern can be implemented on top of a number of different container orchestrators.

To begin with, we will create a small Node.js application that serves definitions of words from the dictionary.

To try this service out, you can run it using a container image:

```
docker run -p 8080:8080 brendanburns/dictionary-s
```

This runs a simple dictionary server on your local machine. For example, you can visit <http://localhost:8080/dog> to see the definition for *dog*.

If you look at the logs for the container, you'll see that it starts serving immediately but only reports readiness after the dictionary (which is approximately 8 MB) has been downloaded over the network.

To deploy this in Kubernetes, you create a **Deployment** :

```
apiVersion: extensions/v1beta1
kind: Deployment
metadata:
  name: dictionary-server
spec:
  replicas: 3
  template:
    metadata:
      labels:
        app: dictionary-server
    spec:
      containers:
        - name: server
```

```
image: brendanburns/dictionary-server
ports:
- containerPort: 8080
readinessProbe:
  httpGet:
    path: /ready
    port: 8080
  initialDelaySeconds: 5
  periodSeconds: 5
```

You can create this replicated stateless service with:

```
kubectl create -f dictionary-deploy.yaml
```

Now that you have a number of replicas, you need a load balancer to bring requests to your replicas. The load balancer serves to distribute the load as well as to provide an abstraction to separate the replicated service from the consumers of the service. The load balancer also provides a resolvable name that is independent of any of the specific replicas.

With Kubernetes, you can create this load balancer with a **Service** object:

```
kind: Service
apiVersion: v1
metadata:
```

```
name: dictionary-server-service
spec:
  selector:
    app: dictionary-server
  ports:
    - protocol: TCP
      port: 8080
      targetPort: 8080
```

Once you have the configuration file, you can create the dictionary service with:

```
kubectl create -f dictionary-service.yaml
```

Session Tracked Services

The previous examples of the stateless replicated pattern routed requests from all users to all replicas of a service. While this ensures an even distribution of load and fault tolerance, it is not always the preferred solution. Often there are reasons for wanting to ensure that a particular user's requests always end up on the same machine. Sometimes this is because you are caching that user's data in memory, so landing on the same machine ensures a higher cache hit rate. Sometimes it is because the interaction is long-running in nature, so some amount of state is maintained

between requests. Regardless of the reason, an adaption of the stateless replicated service pattern is to use session tracked services, which ensure that all requests for a single user map to the same replica, as illustrated in [Figure 6-3](#).

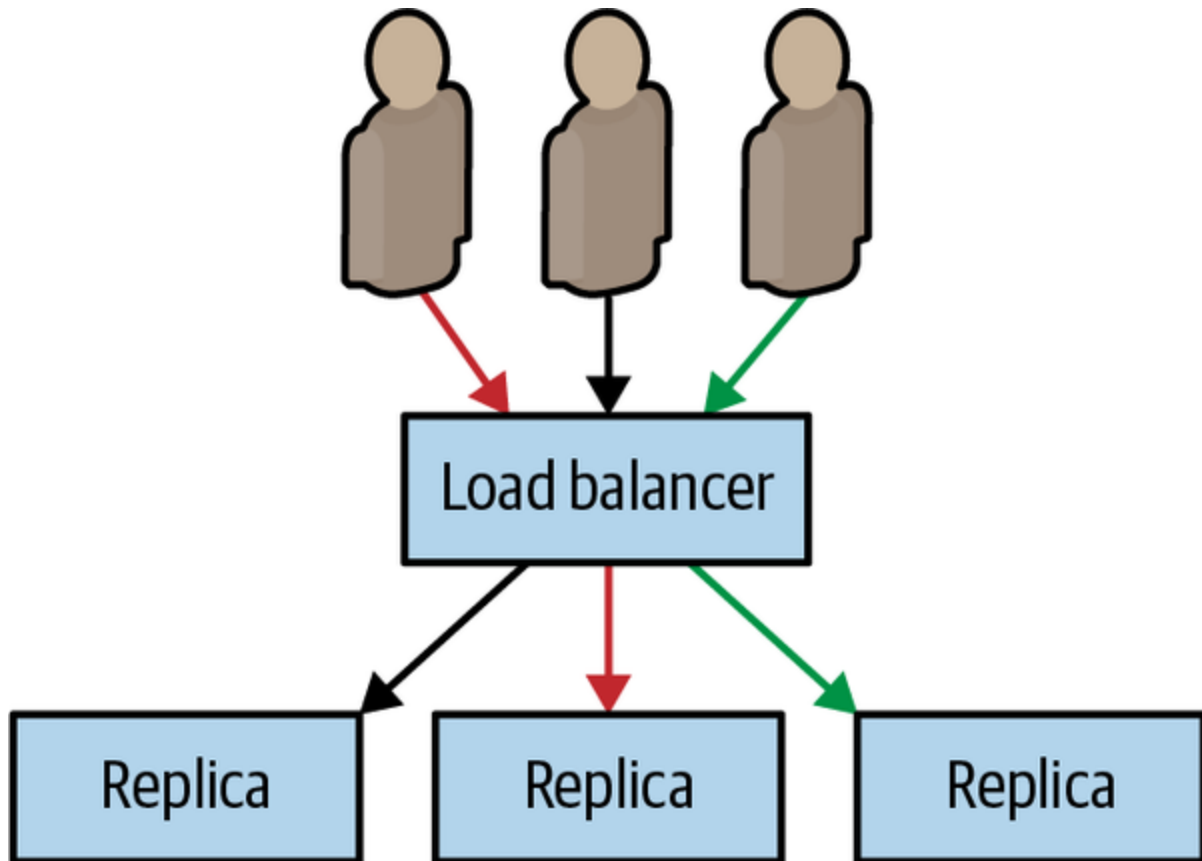

Figure 6-3. A session tracked service where all requests for a specific user are routed to a single instance

Generally speaking, this session tracking is performed by hashing the source and destination IP addresses and using that key to identify the server that should service the requests. So long as the source and destination IP addresses remain constant, all requests are sent to the same replica.

NOTE

IP-based session tracking works within a cluster (internal IPs) but generally doesn't work well with external IP addresses because of network address translation (NAT). For external session tracking, application-level tracking (e.g., via cookies) is preferred.

Often, session tracking is accomplished via a *consistent hashing function*.

The benefit of a consistent hashing function becomes evident when the service is scaled up or down. Obviously, when the number of replicas changes, the mapping of a particular user to a replica may change.

Consistent hashing functions minimize the number of users that actually change which replica they are mapped to, reducing the impact of scaling on your application.

Application-Layer Replicated Services

In all of the preceding examples, the replication and load balancing takes place in the network layer of the service. The load balancing is independent of the actual protocol that is being spoken over the network, beyond TCP/IP. However, many applications use HTTP as the protocol for speaking with each other, and knowledge of the application protocol that is being spoken enables further refinements to the replicated stateless serving pattern for additional functionality.

Introducing a Caching Layer

Sometimes the code in your stateless service is still expensive despite being stateless. It might make queries to a database to service requests or do a significant amount of rendering or data mixing to service the request. In such a world, a caching layer can make a great deal of sense. A cache exists between your stateless application and the end-user request. The simplest form of caching for web applications is a caching web proxy. The caching proxy is simply an HTTP server that maintains the correct responses to user requests in memory. If two users request the same web page or API call, only one request will go to your backend; the other will be serviced out of memory in the cache. This is illustrated in [Figure 6-4](#).

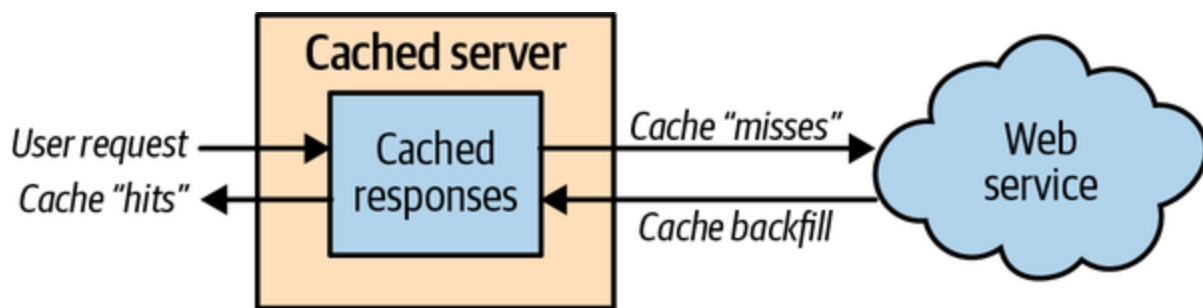

Figure 6-4. The operation of a cache server

For our purposes, we will use [Varnish](#), an open source web cache.

Deploying Your Cache

The simplest way to deploy the web cache is alongside each instance of your web server using the sidecar pattern (see [Figure 6-5](#)).

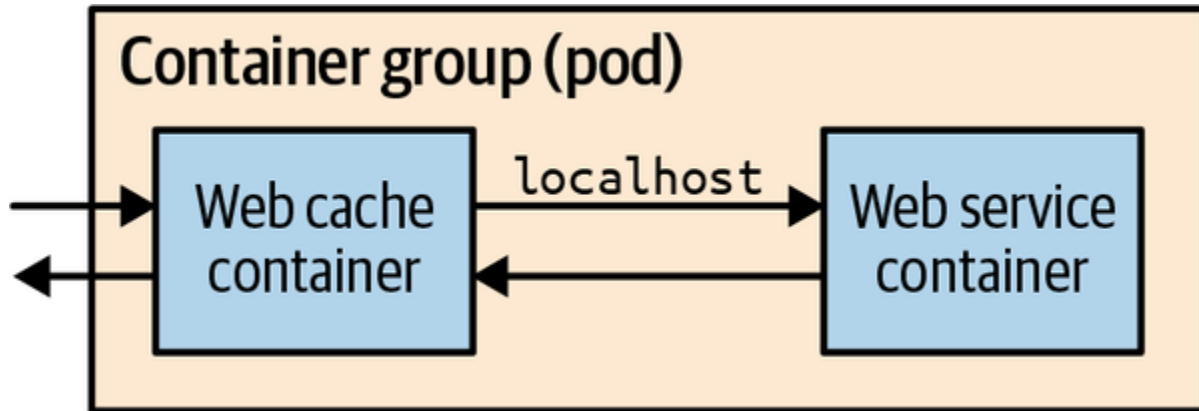

Figure 6-5. Adding the web cache server as a sidecar

Though this approach is simple, it has some disadvantages, namely that you will have to scale your cache at the same scale as your web servers. This is often not the approach you want. For your cache, you want as few replicas as possible with lots of resources for each replica (e.g., rather than 10 replicas with 1 GB of RAM each, you'd want two replicas with 5 GB of RAM each). To understand why this is preferable, consider that every page will be stored in every replica. With 10 replicas, you will store every page 10 times, reducing the overall set of pages that you can keep in memory in the cache. This causes a reduction in the *hit rate*, the fraction of the time that a request can be served out of cache, which in turn decreases the utility of the cache. Though you do want a few large caches, you might also want lots of small replicas of your web servers. Many languages (e.g., Node.js) can really only utilize a single core, and thus you want many replicas to be able to take advantage of multiple cores, even on the same machine.

Therefore, it makes the most sense to configure your caching layer as a second stateless replicated serving tier above your web-serving tier, as illustrated in [Figure 6-6](#).

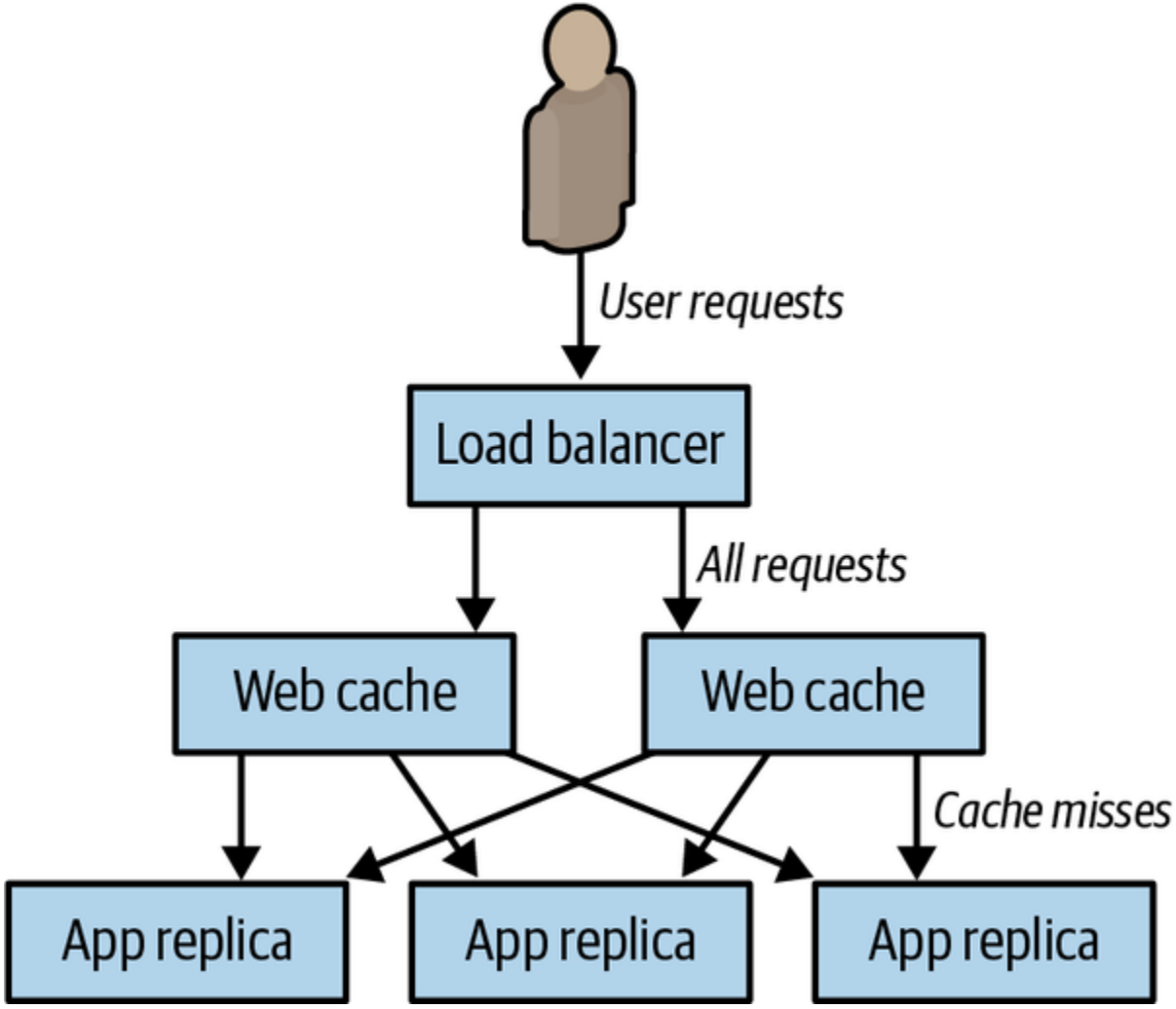

Figure 6-6. Adding the caching layer to our replicated service

NOTE

Unless you are careful, caching can break session tracking. The reason for this is that if you use default IP address affinity and load balancing, all requests will be sent from the IP addresses of the cache, not the end user of your service. If you've followed the advice previously given and deployed a few large caches, your IP-address-based affinity may in fact mean that some replicas of your web layer see *no* traffic. Instead, you need to use something like a cookie or HTTP header for session tracking.

Hands On: Deploying the Caching Layer

The `dictionary-server` service we built earlier distributes traffic to the dictionary server and is discoverable as the DNS name `dictionary-server`. This pattern is illustrated in [Figure 6-7](#).

We can begin building this with the following Varnish cache configuration:

```
vcl 4.0;
backend default {
    .host = "dictionary-server-service";
    .port = "8080";
}
```

Create a `ConfigMap` object to hold this configuration:

```
kubectl create configmap varnish-config --from-f:
```

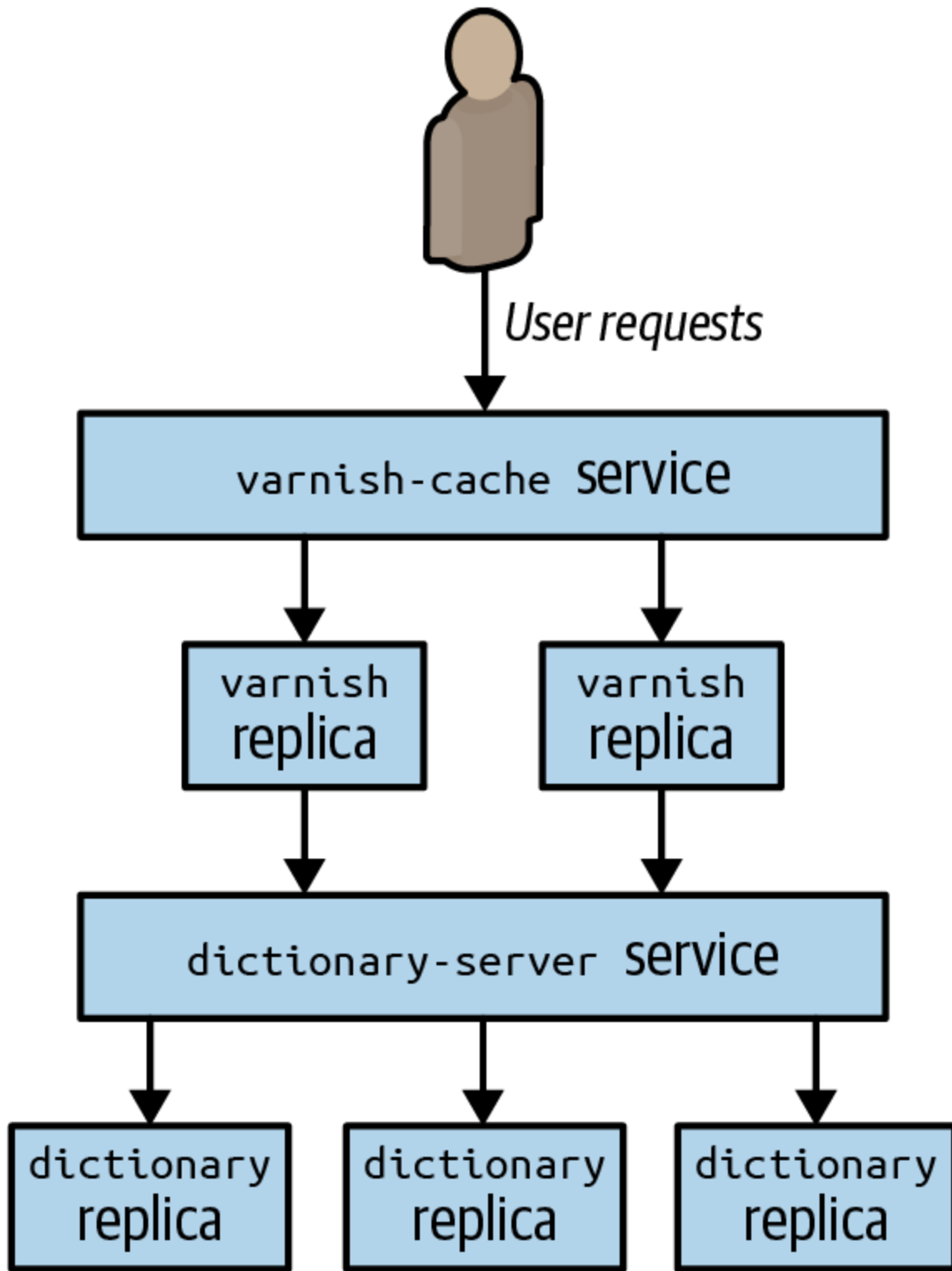

Figure 6-7. Adding a caching layer to the dictionary server

Now we can deploy the replicated Varnish cache, which will load this configuration:

```
apiVersion: extensions/v1beta1
kind: Deployment
metadata:
  name: varnish-cache
spec:
  replicas: 2
  template:
    metadata:
      labels:
        app: varnish-cache
    spec:
      containers:
      - name: cache
        resources:
          requests:
            # We'll use two gigabytes for each v
            memory: 2Gi
        image: brendanburns/varnish
        command:
        - varnishd
        - -F
        - -f
        - /etc/varnish-config/default.vcl
        - -a
        - 0.0.0.0:8080
```

```
- -S
# This memory allocation should match the
- malloc,2G
ports:
- containerPort: 8080
volumeMounts:
- name: varnish
  mountPath: /etc/varnish-config
volumes:
- name: varnish
  configMap:
    name: varnish-config
```

You can deploy the replicated Varnish servers with:

```
kubectl create -f varnish-deploy.yaml
```

And then finally deploy a load balancer for this Varnish cache:

```
kind: Service
apiVersion: v1
metadata:
  name: varnish-service
spec:
  selector:
    app: varnish-cache
```

```
ports:
  - protocol: TCP
    port: 80
    targetPort: 8080
```

which you can create with:

```
kubectl create -f varnish-service.yaml
```

Expanding the Caching Layer

Now that we have inserted a caching layer into our stateless replicated service, let's look at what this layer can provide beyond standard caching. HTTP reverse proxies like Varnish are generally pluggable and can provide a number of advanced features that are useful beyond caching.

Rate Limiting and Denial-of-Service Defense

Few of us build sites with the expectation that we will encounter a denial-of-service attack. But as more and more of us build APIs, a denial of service can come simply from a developer misconfiguring a client or a site-reliability engineer accidentally running a load test against a production installation. Thus, it makes sense to add general denial-of-service defense via rate limiting to the caching layer. Most HTTP reverse proxies like

Varnish have capabilities along this line. In particular, Varnish has a `throttle` module that can be configured to provide throttling based on IP address and request path, as well as whether or not a user is logged in.

If you are deploying an API, it is generally a best practice to have a relatively small rate limit for anonymous access and then force users to log in to obtain a higher rate limit. Requiring a login provides auditing to determine who is responsible for the unexpected load, and also offers a barrier to would-be attackers who need to obtain multiple identities to launch a successful attack.

When a user hits the rate limit, the server will return the `429` error code indicating that too many requests have been issued. However, many users want to understand how many requests they have left before hitting that limit. To that end, you will likely also want to populate an HTTP header with the remaining-calls information. Though there isn't a standard header for returning this data, many APIs return some variation of `X-RateLimit-Remaining`.

NOTE

While Varnish can provide some basic protection against DDoS attacks, in the real world attackers are often sophisticated organizations with large amounts of resources to bring to bear in ever-evolving attacks against organizations. If you are planning on deploying large-scale or mission-critical infrastructure, you will probably also want to add cloud-based denial of service protection from a public cloud provider to your application. Cloud-based DDoS systems can handle significantly more load and also are constantly evolving to meet the changing landscape of threat actors.

SSL Termination

In addition to performing caching for performance, one of the other common tasks performed by the edge layer is SSL termination. Even if you plan on using SSL for communication between layers in your cluster, you should still use different certificates for the edge and your internal services. Indeed, each individual internal service should use its own certificate to ensure that each layer can be rolled out independently. Unfortunately, the Varnish web cache can't be used for SSL termination, but fortunately, the `nginx` application can. Thus, we want to add a third layer to our stateless application pattern, which will be a replicated layer of `nginx` servers that will handle SSL termination for HTTPS traffic and forward traffic on to our Varnish cache. HTTP traffic continues to travel to the Varnish web cache, and Varnish forwards traffic on to our web application, as shown in

[Figure 6-8](#).

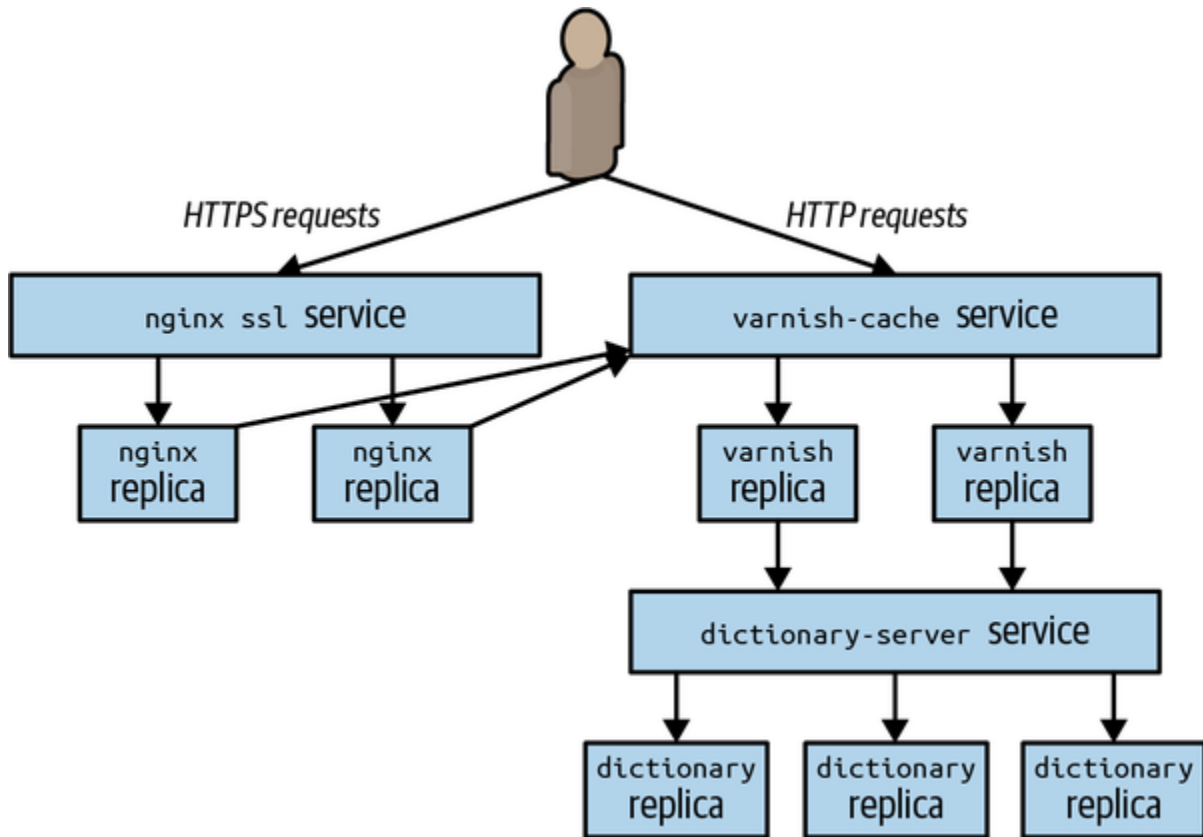

Figure 6-8. Complete replicated stateless serving example

Hands On: Deploying nginx and SSL Termination

The following instructions describe how to add a replicated SSL terminating `nginx` to the replicated service and cache that we previously deployed.

NOTE

These instructions assume that you have a certificate. If you need to obtain a certificate, the easiest way to do that is via the tools at [Let's Encrypt](#). Alternatively, you can use the `openssl` tool to create them. The following instructions assume that you've named them `server.crt` (public certificate) and `server.key` (private key on the server). Such self-signed certificates will cause security alerts in modern web browsers and should never be used for production.

The first step is to upload your certificate as a secret to Kubernetes:

```
kubectl create secret tls ssl --cert=server.crt
```

Once you have uploaded your certificate as a secret, you need to create an `nginx` configuration to serve SSL:

```
events {
    worker_connections 1024;
}

http {
    server {
        listen 443 ssl;
        server_name my-domain.com www.my-domain.com;
        ssl on;
        ssl_certificate      /etc/certs/tls.crt;
        ssl_certificate_key  /etc/certs/tls.key;
        location / {
```

```
    proxy_pass http://varnish-service:80;
    proxy_set_header Host $host;
    proxy_set_header X-Forwarded-For $proxy_add_x_forwarded_for;
    proxy_set_header X-Forwarded-Proto $scheme;
    proxy_set_header X-Real-IP $remote_addr;
  }
}
}
```

As with Varnish, you need to transform this into a `ConfigMap` object:

```
kubectl create configmap nginx-conf --from-file=nginx.conf
```

Now that you have a secret and an `nginx` configuration, it's time to create the replicated stateless `nginx` layer:

```
apiVersion: extensions/v1beta1
kind: Deployment
metadata:
  name: nginx-ssl
spec:
  replicas: 4
  template:
    metadata:
      labels:
```

```
    app: nginx-ssl
spec:
  containers:
  - name: nginx
    image: nginx
    ports:
    - containerPort: 443
    volumeMounts:
    - name: conf
      mountPath: /etc/nginx
    - name: certs
      mountPath: /etc/certs
  volumes:
  - name: conf
    configMap:
      # This is the ConfigMap for nginx we created above
      name: nginx-conf
  - name: certs
    secret:
      # This is the secret we created above
      secretName: ssl
```

To create the replicated `nginx` servers, you use:

```
kubectl create -f nginx-deploy.yaml
```

Finally, you can expose this `nginx` SSL server with a service:

```
kind: Service
apiVersion: v1
metadata:
  name: nginx-service
spec:
  selector:
    app: nginx-ssl
  type: LoadBalancer
  ports:
    - protocol: TCP
      port: 443
      targetPort: 443
```

To create this load-balancing service, run:

```
kubectl create -f nginx-service.yaml
```

If you create this service on a Kubernetes cluster that supports external load balancers, this will create an externalized, public service that services traffic on a public IP address.

To get this IP address, you can run:

```
kubectl get services
```

You should then be able to access the service with your web browser.

Summary

This chapter began with a simple pattern for replicated stateless services. Then we saw how this pattern grows with two additional replicated load-balanced layers to provide caching for performance and SSL termination for secure web serving. This complete pattern for stateless replicated serving is shown in [Figure 6-8](#).

This complete pattern can be deployed into Kubernetes using three `Deployments` and `Service` load balancers to connect the layers shown in [Figure 6-8](#). The complete source for these examples can be found at [this book's GitHub repository](#).

Chapter 7. Sharded Services

In [Chapter 6](#), we saw the value of replicating stateless services for reliability, redundancy, and scaling. This chapter considers sharded services. With the replicated services that we introduced in [Chapter 6](#), each replica was entirely homogeneous and capable of serving every request. In contrast to replicated services, with sharded services, each replica, or *shard*, is only capable of serving a subset of all requests. A load-balancing node, or *root*, is responsible for examining each request and distributing each request to the appropriate shard or shards for processing. The contrast between replicated and sharded services is represented in [Figure 7-1](#).

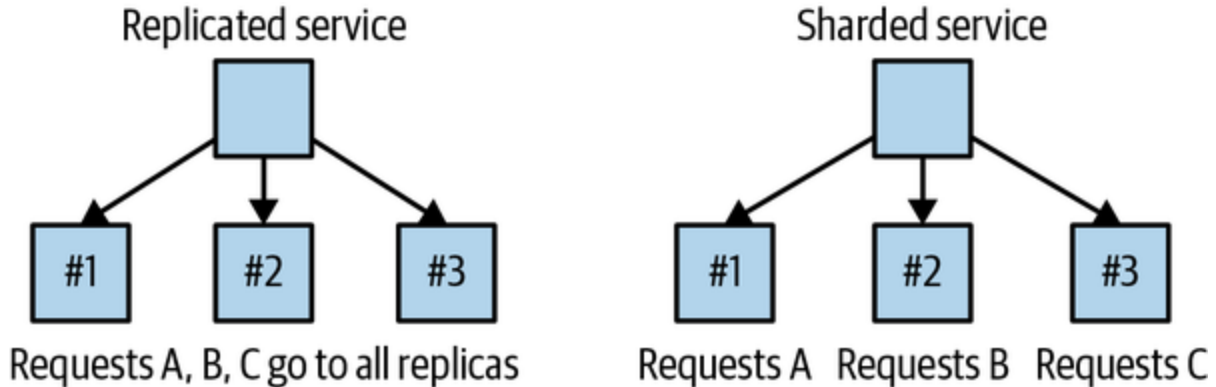

Figure 7-1. Replicated service versus sharded service

Replicated services are generally used for building stateless services, whereas sharded services are generally used for building stateful services. The primary reason for sharding the data is because the size of the state is

too large to be served by a single machine. Sharding enables you to scale a service in response to the size of the state that needs to be served.

Sharding is not exclusively for stateful services, though. Sometimes sharding can also be useful for stateless services for the purpose of isolation. Failures in distributed systems can sometimes come from the input requests to the system (“poison requests”) in a replicated system—if the poison requests come in a large enough volume, they can take down all of the replicas. In such systems, sharding can form an isolation boundary that protects the majority of the requests from the poison ones. Though the poison requests may take out the entire shard, that will only be a fraction of the requests that the system processes.

Sharded Caching

To completely illustrate the design of a sharded system, this section provides a deep dive into the design of a sharded caching system. A *sharded cache* is a cache that sits between the user requests and the actual frontend implementation. A high-level diagram of the system is shown in [Figure 7-2](#).

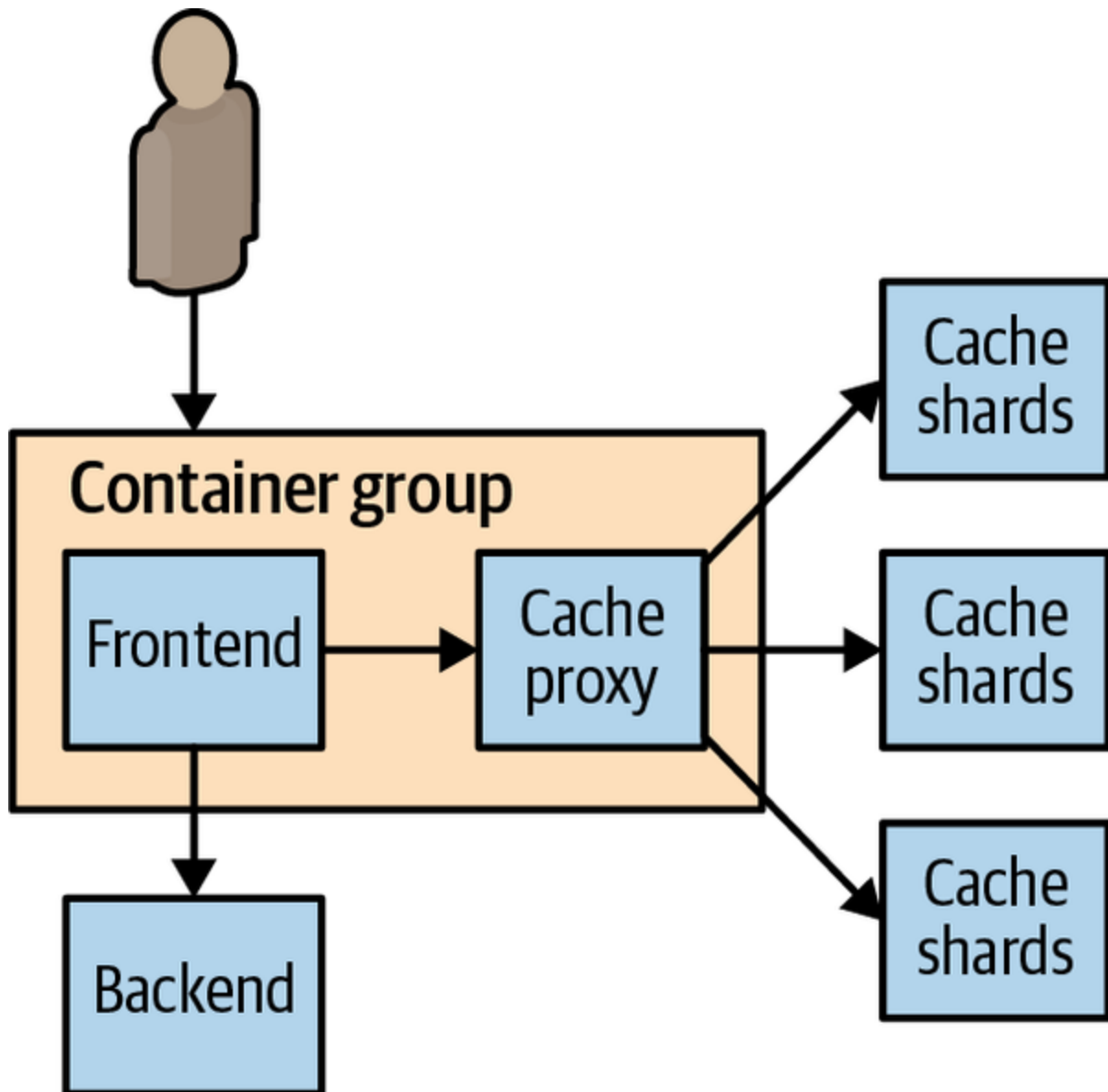

Figure 7-2. A sharded cache

In [Chapter 4](#), we discussed how an ambassador could be used to distribute data to a sharded service. This section discusses how to build that service. When designing a sharded cache, there are a number of design aspects to consider:

- Why you might need a sharded cache

- The role of the cache in your architecture
- Replicated sharded caches
- The sharding function

Why You Might Need a Sharded Cache

Reminder: the primary reason for sharding any service is to increase the size of the data being stored in the service. To understand how this helps a caching system, imagine the following system: each cache has 10 GB of RAM available to store results, and can serve 100 requests per second (RPS). Suppose then that our service has a total of 200 GB possible results that could be returned, and an expected 1,000 RPS. Clearly, we need 10 replicas of the cache in order to satisfy 1,000 RPS ($10 \text{ replicas} \times 100 \text{ requests per second per replica}$). The simplest way to deploy this service would be as a replicated service, as described in [Chapter 6](#). But deployed this way, the distributed cache can only hold a maximum of 5% ($10 \text{ GB}/200 \text{ GB}$) of the total data set that we are serving. This is because each cache replica is independent, and thus each cache replica stores roughly the exact same data in the cache. This is great for redundancy, but pretty terrible for maximizing memory utilization. If instead, we deploy a 10-way sharded cache, we can still serve the appropriate number of RPS (10×100 is still 1,000), but because each cache serves a completely unique set of data, we are able to store 50% ($10 \times 10 \text{ GB}/200 \text{ GB}$) of the total data set. This tenfold increase in cache storage means that the memory for the cache is much better utilized, since each key exists only in a single cache. The more

data we store in the cache, the faster the overall system will be able to operate since more requests can be served from the cache.

The Role of the Cache in System Performance

In [Chapter 6](#) we discussed how caches can be used to optimize end-user performance and latency, but one thing that wasn't covered was the criticality of the cache to your application's performance, reliability, and stability.

Put simply, the important question for you to consider is: if the cache were to fail, what would the impact be for your users and your service?

When we discussed the replicated cache, this question was less relevant because the cache itself was horizontally scalable, and failures of specific replicas would only lead to transient failures. Likewise, the cache could be horizontally scaled in response to increased load without impacting the end user.

This changes when you consider sharded caches. Because a specific user or request is always mapped to the same shard, if that shard fails, that user or request will always miss the cache until the shard is restored. Given the nature of a cache as transient data, this miss is not inherently a problem, and your system must know how to recalculate the data. However, this

recalculation is inherently slower than using the cache directly, and thus it has performance implications for your end users.

The performance of your cache is defined in terms of its *hit rate*. The hit rate is the percentage of the time that your cache contains the data for a user request. Ultimately, the hit rate determines the overall capacity of your distributed system and affects the overall capacity and performance of your system.

Imagine, if you will, that you have a request-serving layer that can handle 1,000 RPS. After 1,000 RPS, the system starts to return `HTTP 500` errors to users. If you place a cache with a 50% hit rate in front of this request-serving layer, adding this cache increases your maximum RPS from 1,000 RPS to 2,000 RPS. To understand why this is true, you can see that of the 2,000 inbound requests, 1,000 (50%) can be serviced by the cache, leaving 1,000 requests to be serviced by your serving layer. In this instance, the cache is fairly critical to your service, because if the cache fails, then the serving layer will be overloaded and half of all your user requests will fail. Given this, it likely makes sense to rate your service at a maximum of 1,500 RPS rather than the full 2,000 RPS. If you do this, then you can sustain a failure of half of your cache replicas and still keep your service stable.

But the performance of your system isn't just defined in terms of the number of requests that it can process. Your system's end-user performance is defined in terms of the *latency* of requests as well. A result from a cache

is generally significantly faster than calculating that result from scratch. Consequently, a cache can improve the speed of requests as well as the total number of requests processed. To see why this is true, imagine that your system can serve a request from a user in 100 milliseconds. You add a cache with a 25% hit rate that can return a result in 10 milliseconds. Thus, the average latency for a request in your system is now 77.5 milliseconds. Unlike maximum requests per second, the cache simply makes your requests faster, so there is somewhat less need to worry about the fact that requests will slow down if the cache fails or is being upgraded. However, in some cases, the performance impact can cause too many user requests to pile up in request queues and ultimately time out. It's always recommended that you load test your system both with and without caches to understand the impact of the cache on the overall performance of your system.

Finally, it isn't just failures that you need to think about. If you need to upgrade or redeploy a sharded cache, you cannot just deploy a new replica and assume it will immediately take the existing load. A newly created cache shard doesn't have any data stored in memory. Responses are cached as they are received in response to user requests. A newly deployed cache needs to be "warmed up" or filled with responses before it can provide maximal benefit. Deploying a new version of a sharded cache will generally result in temporarily losing some capacity. Another, more advanced option is to replicate your shards.

Replicated Sharded Caches

Sometimes your system is so dependent on a cache for latency or load that it is not acceptable to lose an entire cache shard if there is a failure or you are doing a rollout. Alternatively, you may have so much load on a particular cache shard that you need to scale it to handle the load. For these reasons, you may choose to deploy a sharded replicated service. A sharded replicated service combines the replicated service pattern described in [Chapter 6](#) with the sharded pattern described in previous sections. In a nutshell, rather than having a single server implement each shard in the cache, a replicated service is used to implement each cache shard.

This design is obviously more complicated to implement and deploy, but it has several advantages over a simple sharded service. Most importantly, by replacing a single server with a replicated service, each cache shard is resilient to failures and is always present during failures. Rather than designing your system to be tolerant to performance degradation resulting from cache shard failures, you can rely on the performance improvements that the cache provides. Assuming that you are willing to over-provision shard capacity, this means that it is safe for you to do a cache rollout during peak traffic, rather than waiting for a quiet period for your service.

Additionally, because each replicated cache shard is an independent replicated service, you can scale each cache shard in response to its load; this sort of “hot sharding” is discussed at the end of this chapter.

Hands On: Deploying an Ambassador and Memcache for a Sharded Cache

In [Chapter 4](#) we saw how to deploy a sharded Redis service. Deploying a sharded memcache is similar.

First, we will deploy memcache as a Kubernetes `StatefulSet` :

```
apiVersion: apps/v1
kind: StatefulSet
metadata:
  name: sharded-memcache
spec:
  serviceName: "memcache"
  replicas: 3
  template:
    metadata:
      labels:
        app: memcache
    spec:
      terminationGracePeriodSeconds: 10
      containers:
      - name: memcache
        image: memcached
        ports:
        - containerPort: 11211
          name: memcache
```

Save this to a file named *memcached-shards.yaml*, and you can deploy this with `kubectl create -f memcached-shards.yaml`. This will create three containers running memcached.

As with the sharded Redis example, we also need to create a Kubernetes **Service** that will create DNS names for the replicas we have created.

The service looks like this:

```
apiVersion: v1
kind: Service
metadata:
  name: memcache
  labels:
    app: memcache
spec:
  ports:
    - port: 11211
      name: memcache
  clusterIP: None
  selector:
    app: memcache
```

Save this to a file named *memcached-service.yaml* and deploy it with `kubectl create -f memcached-service.yaml`. You should now have DNS entries for `memcache-0.memcache`, `memcache-`

1.memcache , etc. As with Redis, we can use these names to configure [twemproxy](#):

```
memcache:
  listen: 127.0.0.1:11211
  hash: fnv1a_64
  distribution: ketama
  auto_eject_hosts: true
  timeout: 400
  server_retry_timeout: 2000
  server_failure_limit: 1
  servers:
    - memcache-0.memcache:11211:1
    - memcache-1.memcache:11211:1
    - memcache-2.memcache:11211:1
```

In this config, you can see that we are serving the memcache protocol on `localhost:11211` so that the application container can access the ambassador. We will deploy this into our ambassador pod using a Kubernetes `ConfigMap` object that we can create with: `kubectl create configmap --from-file=nutcracker.yaml twem-config`.

Finally, all of the preparations are done, and we can deploy our ambassador example. We define a pod that looks like this:

```
apiVersion: v1
kind: Pod
metadata:
  name: sharded-memcache-ambassador
spec:
  containers:
    # This is where the application container would go
    # - name: nginx
    #   image: nginx
    # This is the ambassador container
    - name: twemproxy
      image: ganomede/twemproxy
      command:
        - nutcracker
        - -c
        - /etc/config/nutcracker.yaml
        - -v
        - 7
        - -s
        - 6222
      volumeMounts:
        - name: config-volume
          mountPath: /etc/config
  volumes:
    - name: config-volume
      configMap:
        name: twem-config
```

You can save this to a file named *memcached-ambassador-pod.yaml*, and then deploy it with:

```
kubectl create -f memcached-ambassador-pod.yaml
```

Of course, we don't have to use the ambassador pattern if we don't want to. An alternative is to deploy a replicated *shard router* service. There are trade-offs between using an ambassador versus using a shard routing service. The value of the service is a reduction of complexity. You don't have to deploy the ambassador with every pod that wants to access the sharded memcache service; it can be accessed via a named and load-balanced service. The downside of a shared service is twofold. First, because it is a shared service, you will have to scale it larger as demand load increases. Second, using the shared service introduces an extra network hop that will add some latency to requests and contribute network bandwidth to the overall distributed system.

To deploy a shared routing service, you need to change the `twemproxy` configuration slightly so that it listens on all interfaces, not just localhost:

```
memcache:  
  listen: 0.0.0.0:11211  
  hash: fnv1a_64
```

```
distribution: ketama
auto_eject_hosts: true
timeout: 400
server_retry_timeout: 2000
server_failure_limit: 1
servers:
  - memcache-0.memcache:11211:1
  - memcache-1.memcache:11211:1
  - memcache-2.memcache:11211:1
```

You can save this to a file named *shared-nutcracker.yaml*, and then create a corresponding `ConfigMap` using `kubectl`:

```
kubectl create configmap --from-file=shared-nutcracker.yaml
```

Then you can turn up the replicated shard routing service as a `Deployment`:

```
apiVersion: extensions/v1
kind: Deployment
metadata:
  name: shared-twemproxy
spec:
  replicas: 3
  template:
    metadata:
```

```
  labels:
    app: shared-twemproxy
spec:
  containers:
  - name: twemproxy
    image: ganomede/twemproxy
    command:
    - nutcracker
    - -c
    - /etc/config/shared-nutcracker.yaml
    - -v
    - 7
    - -s
    - 6222
    volumeMounts:
    - name: config-volume
      mountPath: /etc/config
  volumes:
  - name: config-volume
    configMap:
      name: shared-twem-config
```

If you save this to *shared-twemproxy-deploy.yaml*, you can create the replicated shard router using `kubectl`:

```
kubectl create -f shared-twemproxy-deploy.yaml
```

To complete the shard router, we have to declare a load balancer to process requests:

```
kind: Service
apiVersion: v1
metadata:
  name: shard-router-service
spec:
  selector:
    app: shared-twemproxy
  ports:
    - protocol: TCP
      port: 11211
      targetPort: 11211
```

This load balancer can be created using `kubectl create -f shard-router-service.yaml`.

An Examination of Sharding Functions

So far we've discussed the design and deployment of both simple sharded and replicated sharded caches, but we haven't spent very much time considering how traffic is routed to different shards. Consider a sharded service where you have 10 independent shards. Given some specific user request *Req*, how do you determine which shard *S* in the range from zero to

nine should be used for the request? This mapping is the responsibility of the *sharding function*. A sharding function is very similar to a hashing function, which you may have encountered when learning about hashtable data structures. Indeed, a bucket-based hashtable could be considered an example of a sharded service. Given both *Req* and *Shard*, then the role of the sharding function is to relate them together, specifically:

- $Shard = ShardingFunction(Req)$

Commonly, the sharding function is defined using a *hashing function* and the modulo (%) operator. Hashing functions are functions that transform an arbitrary object into an integer *hash*. The hash function has two important characteristics for our sharding:

Determinism

The output should always be the same for a unique input.

Uniformity

The distribution of outputs across the output space should be equal.

For our sharded service, determinism and uniformity are the most important characteristics. Determinism is important because it ensures that a particular request *R* always goes to the same shard in the service. Uniformity is important because it ensures that load is evenly spread between the different shards.

Fortunately for us, modern programming languages include a wide variety of high-quality hash functions. However, the outputs of these hash functions are often significantly larger than the number of shards in a sharded service. Consequently, we use the modulo operator (%) to reduce a hash function to the appropriate range. Returning to our sharded service with 10 shards, we can see that we can define our sharding function as:

- $Shard = hash(Req) \% 10$

If the output of the hash function has the appropriate properties in terms of determinism and uniformity, those properties will be preserved by the modulo operator.

Selecting a Key

Given this sharding function, it might be tempting to simply use the hashing function that is built into the programming language, hash the entire object, and call it a day. The result of this, however, will not be a very good sharding function.

To understand this, consider a simple HTTP request that contains three things:

- The time of the request
- The source IP address from the client
- The HTTP request path (e.g., */some/page.html*)

If we use a simple object-based hashing function, `shard (request)`, then it is clear that `{12:00, 1.2.3.4, /some/file.html}` has a different shard value than `{12:01, 5.6.7.8, /some/file.html}`. The output of the sharding function is different because the client's IP address and the time of the request are different between the two requests. But of course, in most cases, the IP address of the client and the time of the request don't impact the response to the HTTP request. Consequently, instead of hashing the entire request object, a much better sharding function would be `shard (request . path)`. When we use `request . path` as the shard key, then we map both requests to the same shard, and thus the response to one request can be served out of the cache to service the other.

Of course, sometimes client IP *is* important to the response that is returned from the frontend. For example, client IP may be used to look up the geographic region that the user is located in, and different content (e.g., different languages) may be returned to different IP addresses. In such cases, the previous sharding function `shard (request . path)` will actually result in errors, since a cache request from a French IP address may be served a result page from the cache in English. In such cases, the cache function is too *general*, as it groups together requests that do not have identical responses.

Given this problem, it would be tempting then to define our sharding function as `shard (request . ip, request . path)`, but this

sharding function has problems as well. It will cause two different French IP addresses to map to different shards, thus resulting in inefficient sharding. This shard function is too *specific*, as it fails to group together requests that are identical. A better sharding function for this situation would be:

- `shard (country (request . ip), request . path)`

This first determines the country from the IP address, and then uses that country as part of the key for the sharding function. Thus, multiple requests from France will be routed to one shard, while requests from the United States will be routed to a different shard.

Determining the appropriate key for your sharding function is vital to the optimal design of a sharded system. Determining the correct shard key requires an understanding of the requests that you expect to see.

Consistent Hashing Functions

Setting up the initial shards for a new service is relatively straightforward: you set up the appropriate shards and the roots to perform the sharding, and you are off to the races. However, what happens when you need to change the number of shards in your sharded service? Such “re-sharding” is often a complicated process.

To understand why this is true, consider the sharded cache previously examined. Certainly, scaling the cache from 10 to 11 replicas is straightforward to do with a container orchestrator, but consider the effect of changing the scaling function from $hash(Req) \% 10$ to $hash(Req) \% 11$. When you deploy this new scaling function, a large number of requests are going to be mapped to a different shard than the one they were previously mapped to. In a sharded cache, this is going to temporarily cause a dramatic increase in your *miss rate* until the cache is repopulated with responses for the new requests that have been mapped to that cache shard by the new sharding function. In the worst case, rolling out a new sharding function for your sharded cache will be equivalent to a complete cache failure.

To resolve these kinds of problems, many sharding functions use *consistent hashing functions*. Consistent hashing functions are special hash functions that are guaranteed to only remap $\# keys / \# shards$, when being resized to $\# shards$. For example, if we use a consistent hashing function for our sharded cache, moving from 10 to 11 shards will only result in remapping $< 10\%$ ($K / 11$) keys. This is dramatically better than losing the entire sharded service.

Hands On: Building a Consistent HTTP Sharding Proxy

To shard HTTP requests, the first question to answer is what to use as the key for the sharding function. Though there are several options, a good general-purpose key is the request path as well as the fragment and query

parameters (i.e., everything that makes the request unique). Note that this does *not* include cookies from the user or the language/location (e.g., EN_US). If your service provides extensive customization to users or their location, you will need to include them in the hash key as well.

We can use the versatile `nginx` HTTP server for our sharding proxy:

```
worker_processes 5;
error_log error.log;
pid nginx.pid;
worker_rlimit_nofile 8192;

events {
    worker_connections 1024;
}

http {
    # define a named 'backend' that we can use in
    # below.
    upstream backend {
        # Has the full URI of the request and use
        hash $request_uri consistent
        server web-shard-1.web;
        server web-shard-2.web;
        server web-shard-3.web;
    }

    server {
```

```
server {  
    listen localhost:80;  
    location / {  
        proxy_pass http://backend;  
    }  
}
```

Note that we chose to use the full request URI as the key for the hash and use the key word `consistent` to indicate that we want to use a consistent hashing function.

Sharded Replicated Serving

Most of the examples in this chapter so far have described sharding in terms of cache serving. But, of course, caches are not the only kinds of services that can benefit from sharding. Sharding is useful when considering any sort of service where there is more data than can fit on a single machine. In contrast to previous examples, the key and sharding function are not a part of the HTTP request, but rather some context for the user.

For example, consider implementing a large-scale multiplayer game. Such a game world is likely to be far too large to fit on a single machine. However, players who are distant from each other in this virtual world are unlikely to interact. Consequently, the world of the game can be *sharded* across many

different machines. The sharding function is keyed off of the player's location so that all players in a particular location land on the same set of servers.

Hot Sharding Systems

Ideally the load on a sharded cache will be perfectly even, but in many cases this isn't true, and "hot shards" appear because organic load patterns drive more traffic to one particular shard.

As an example of this, consider a sharded cache for a user's photos; when a particular photo goes viral and suddenly receives a disproportionate amount of traffic, the cache shard containing that photo will become "hot." When this happens, with a replicated sharded cache, you can scale the cache shard to respond to the increased load. Indeed, if you set up autoscaling for each cache shard, you can dynamically grow and shrink each replicated shard as the organic traffic to your service shifts around. An illustration of this process is shown in [Figure 7-3](#). Initially the sharded service receives equal traffic to all three shards. Then the traffic shifts so that Shard A is receiving four times as much traffic as Shard B and Shard C. The hot sharding system moves Shard B to the same machine as Shard C, and replicates Shard A to a second machine. Traffic is now, once again, equally shared among replicas.

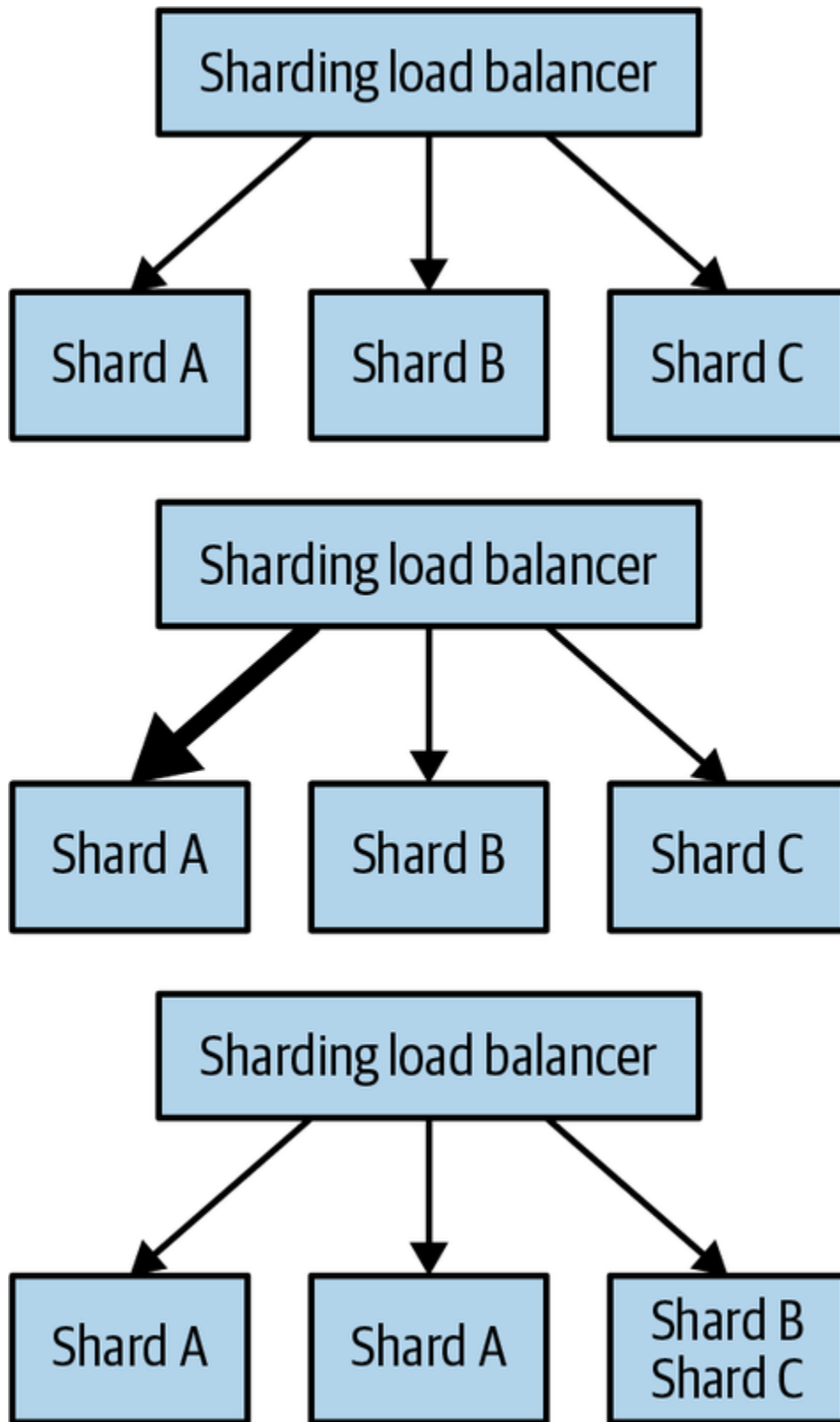

Figure 7-3. An example of a hot sharded system: initially the shards are evenly distributed, but when extra traffic comes to shard A, it is replicated to two machines, and shards B and C are combined on

a single machine

Summary

This chapter introduced the concept of sharding, which directs particular requests to particular groups of machines instead of load-balancing all traffic to all replicas of a service. An example was given of how sharding can significantly improve the efficiency and performance of a caching system attached to a serving API. Sharding is not just useful for caching, however. Systems like large-scale open world game servers and databases can scale beyond the size limits of a single machine by sharding their data across multiple different shard servers. Sharding also helps with isolation, limiting the blast radius of poison requests to a subset of all servers. Setting up a sharded system requires a careful understanding and design of both the shard key and the key hashing function. Identifying the right way to partition your data can often make the difference between a scalable system and one which runs into bottlenecks as it scales. Understanding the details of sharding is critical to building larger and more complex distributed systems.

Chapter 8. Scatter/Gather

So far we've examined systems that replicate for scalability in terms of the number of requests processed per second (the stateless replicated pattern), as well as scalability for the size of the data (the sharded data pattern). In this chapter we introduce the *scatter/gather* pattern, which uses replication for scalability in terms of time. Specifically, the scatter/gather pattern allows you to achieve parallelism in servicing requests, enabling you to service them significantly faster than you could if you had to service them sequentially.

Like replicated and sharded systems, the scatter/gather pattern is a tree pattern with a root that distributes requests and leaves that process those requests. However, in contrast to replicated and sharded systems, scatter/gather requests are simultaneously farmed out to all of the replicas in the system. Each replica does a small amount of processing and then returns a fraction of the result to the root. The root server then combines the various partial results together to form a single complete response to the request and then sends this request back out to the client. The scatter/gather pattern is illustrated in [Figure 8-1](#).

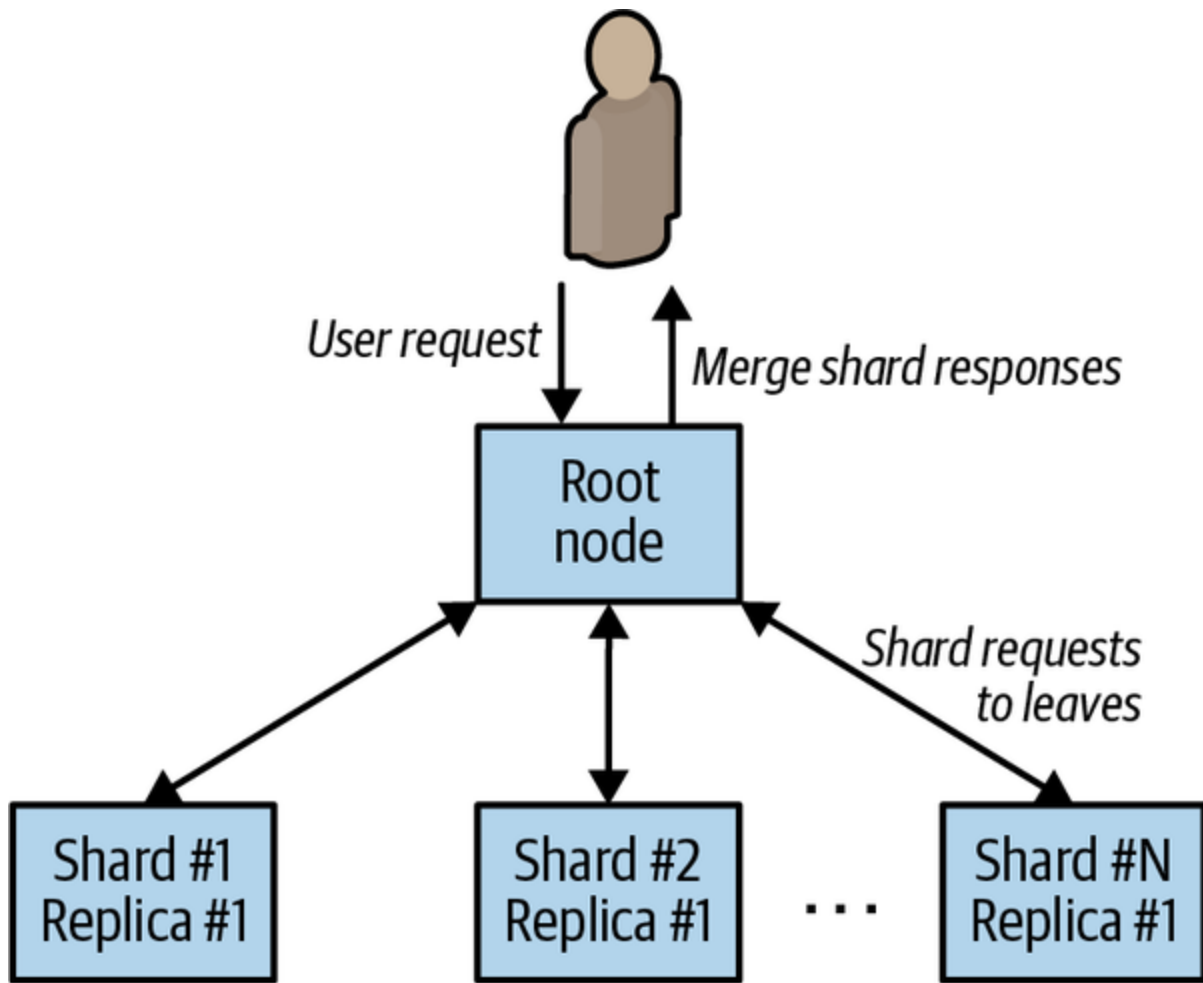

Figure 8-1. A scatter/gather pattern

Scatter/gather is quite useful when you have a large amount of mostly independent processing that is needed to handle a particular request. With such problems, it is relatively easy to spread the computation required across multiple different independent processors.

Whereas the previous examples of caching sharded the data to maximize the efficiency of memory usage, the scatter/gather algorithm shards the computation necessary to service the request, reducing the latency via

parallel processing. Though sometimes, as we will see, the data is sharded as well.

Scatter/Gather with Root Distribution

The simplest form of scatter/gather is one in which each leaf is entirely homogenous but the work is distributed to a number of different leaves in order to improve the performance of the request. This pattern is equivalent to solving an “embarrassingly parallel” problem. The problem can be broken up into many different pieces, and each piece can be put back together with all of the other pieces to form a complete answer.

To understand this in more concrete terms, imagine that you need to service a user request R , and it takes one minute for a single core to produce the answer A to this request. If we program a multithreaded application, we can parallelize this request on a single machine by using multiple cores. Given this approach and a 30-core processor (yes, typically it would be a 32-core processor, but 30 makes the math cleaner), we can reduce the time that it takes to process a single request down to 2 seconds (60 seconds of computation split across 30 threads for computation is equal to 2 seconds). But even 2 seconds is pretty slow to service a user’s web request.

Additionally, truly achieving a completely parallel speed-up on a single process is going to be tricky, as things like memory, network, or disk bandwidth start to become the bottleneck. Instead of (or in addition to)

parallelizing an application across cores on a single machine, we can use the scatter/gather pattern to parallelize requests across multiple processes on many different machines. In this way, we can improve our overall latency requests, since we are no longer bound by the number of cores we can get on a single machine, as well as ensure that the bottleneck in our process continues to be CPU, since the memory, network, and disk bandwidth are all spread across a number of different machines. Additionally, because every machine in the scatter/gather tree is capable of handling every request, the root of the tree can dynamically dispatch load to different nodes at different times depending on their responsiveness. If, for some reason, a particular leaf node is responding more slowly than other machines (e.g., it has a noisy neighbor process that is interfering with resources), then the root can dynamically redistribute load to assure a fast response.

Hands On: Distributed Document Search

To see an example of scatter/gather in action, consider the task of searching across a large database of documents for all documents that contain the words “cat” and “dog.” One way to perform this search would be to open up all of the documents, read through the entire set, searching for the words in each document, and then return to the user the set of documents that contain both words.

As you might imagine, this is quite a slow process because it requires opening and reading through a large number of files for each request. To

make request processing faster, you can build an *index*. Just like in the back of a reference book, the index is effectively a hashtable, where the keys are individual words (e.g., “cat”) and the values are a list of documents (or pages) containing that word.

Now, instead of searching through every document, finding the documents that match any one word is as easy as doing a lookup in this hashtable. However, we have lost one important ability. Remember that we were looking for all documents that contained “cat” *and* “dog.” Since the index only has single words, not conjunctions of words, we still need to find the documents that contain both words. Luckily, this is just an intersection of the sets of documents returned for each word.

We could implement this algorithm on a single machine. Step one would be to use the index to look up the list of documents containing *cat*. Step two would be to use the index to look up the list of documents containing *dog*. And the final step would be to find the intersection, the documents which are present in both lists. Looking at these steps, it’s clear that the lookup for *cat* and the lookup for *dog* are independent; they can easily be performed in parallel and can even be performed on different machines. Calculating the intersection, however, requires both lists of documents, and thus is dependent on the data from the first two steps.

Given this understanding, we can implement this document search as an example of the scatter/gather pattern. When a request comes in to the

document search root, it parses the request and farms out to two leaf machines (one for the word “cat” and one for the word “dog”). Each of these machines returns a list of documents that match one of the words, and the root node returns the list of documents containing both “cat” and “dog.”

A diagram of this process is shown in [Figure 8-2](#): the leaf returns {doc1, doc2, doc4} for “cat” and {doc1, doc3, doc4} for “dog,” so the root finds the intersection and returns {doc1, doc4} .

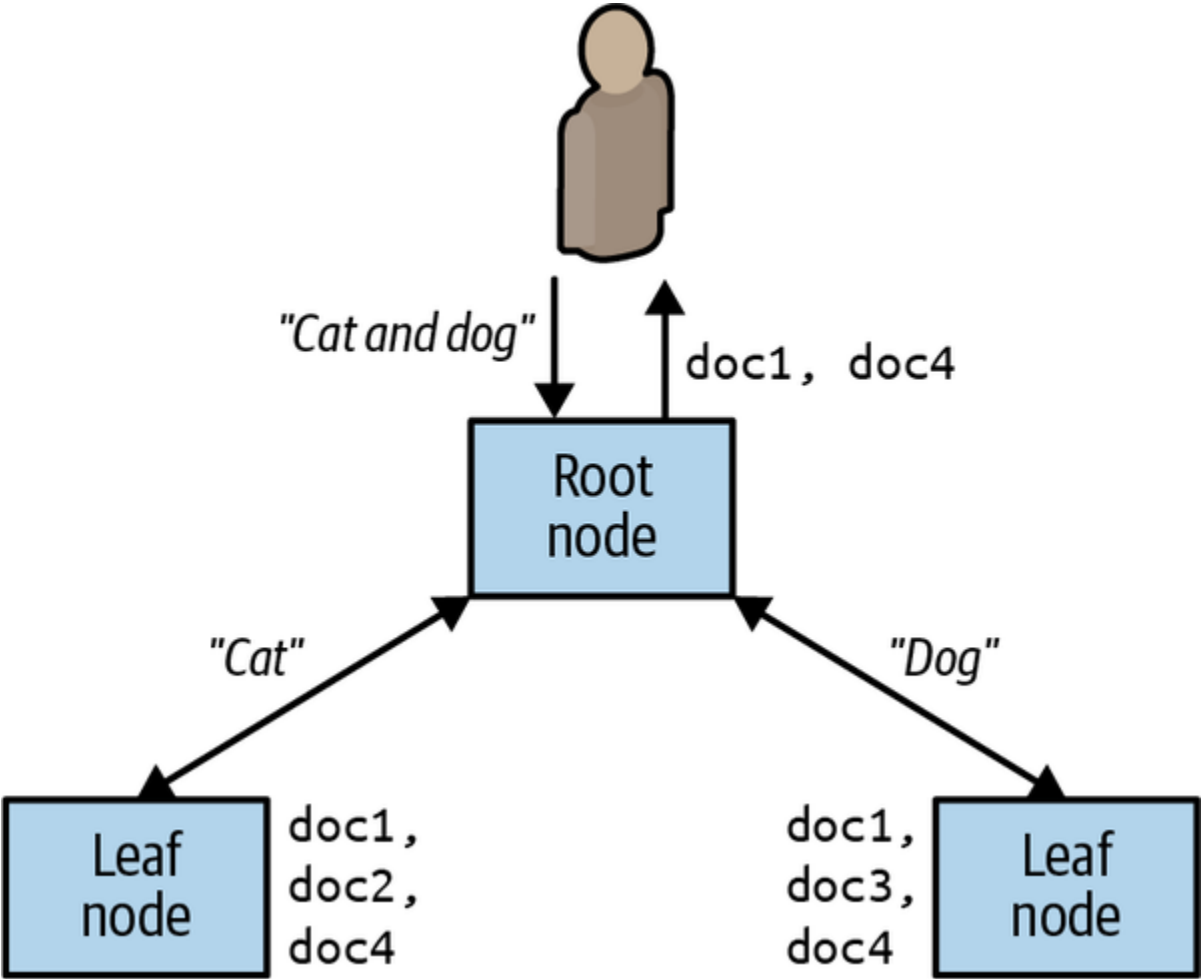

Figure 8-2. Example of a term-sharded scatter/gather system

Scatter/Gather with Leaf Sharding

While applying the replicated data scatter/gather pattern allows you to reduce the processing time required for handling user requests, it doesn't allow you to scale beyond an amount of data that can be held in the memory or disk of a single machine. Much like the replicated serving pattern that was previously described, it is simple to build a replicated scatter/gather system. But at a certain data size, it is necessary to introduce sharding in order to build a system that can hold more data than can be stored on a single machine.

Previously, when sharding was introduced to scale replicated systems, the sharding was done at a per-request level. Some part of the request was used to determine where the request was sent. That replica then handled all of the processing for the request, and the response was handed back to the user. Instead, with scatter/gather sharding, the request is sent to all of the leaf nodes (or shards) in the system. Each leaf node processes the request using the data that it has loaded in its shard. This partial response is then returned to the root node that requested data, and that root node merges all of the responses together to form a comprehensive response for the user.

As a concrete example of this sort of architecture, consider implementing search across a very large document set (all patents in the world, for example); in such a case, the data is too large to fit in the memory of a

single machine, so instead the data is sharded across multiple replicas. For example, patents 0–100,000 might be on the first machine, 100,001–200,000 on the next machine, and so forth. (Note that this is not actually a good sharding scheme since it will continually force us to add new shards as new patents are registered. In practice, we’d likely use the patent number modulo the total number of shards.)

When a user submits a request to find a particular word (e.g., “rockets”) in all of the patents in the index, that request is sent to each shard, which searches through its patent shard for patents that match the word in the query. Any matches that are found are returned to the root node in response to the shard request. The root node then collates all of these responses together into a single response that contains all the patents that match the particular word. The operation of this search index is illustrated in [Figure 8-3](#).

Hands On: Sharded Document Search

The previous example scattered the different term requests across the cluster, but this only works if all of the documents are present on all of the machines in the scatter/gather tree. If there is not enough room for all of the documents in all of the leaves in the tree, then sharding must be used to put different sets of documents onto different leaves.

This means that when a user makes a request for all documents that match the words “cat” and “dog,” the request is actually sent out to every leaf in the scatter/gather system. Each leaf node returns the set of documents that it knows about that matches “cat” and “dog.” Previously, the root node was responsible for performing the intersection of the two sets of documents returned for two different words. In the sharded case, the root node is responsible for generating the union of all of the documents returned by all of the different shards and returning this complete set of documents back up to the user.

In [Figure 8-3](#), the first leaf serves documents 1 through 10 and returns {doc1, doc5} . The second leaf serves documents 11 through 20 and returns {doc15} . The third leaf serves documents 21 through 30 and returns {doc22, doc28} . The root combines all of these responses together into a single response and returns {doc1, doc5, doc15, doc22, doc28} .

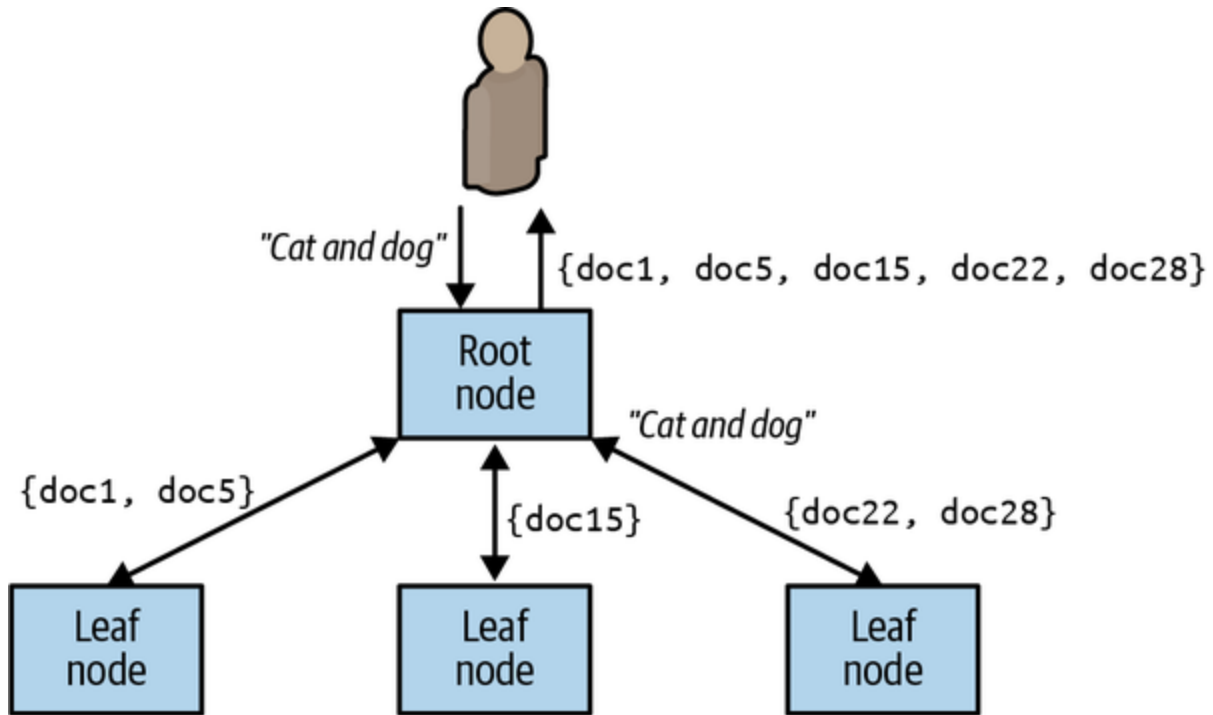

Figure 8-3. Conjunctive query executing in a scatter/gather search system

Choosing the Right Number of Leaves

It might seem that in the scatter/gather pattern, replicating out to a very large number of leaves would always be a good idea. You parallelize your computation and consequently reduce the clock time required to process any particular request. However, increased parallelization comes at a cost, and thus choosing the right number of leaf nodes in the scatter/gather pattern is critical to designing a performant distributed system.

To understand how this can happen, it's worth considering two things. The first is that processing any particular request has a certain amount of overhead. This includes the time spent parsing a request, sending requests across the network, and performing encryption. In general, the overhead

due to system request handling is constant and significantly less than the time spent in user code processing the request. Consequently, this overhead can generally be ignored when assessing the performance of the scatter/gather pattern. However, it is important to understand that you pay the cost of this overhead on every leaf node in the scatter/gather system. Each leaf node you add to increase parallelism increases the total overhead cost. Additionally, increasing the parallelism reduces the time spent performing “useful” computation on each leaf node, until eventually the time spent on the computational overhead is significantly greater than the time spent performing “useful” computation. When this happens, you can no longer improve performance by adding additional leaf nodes. This means that the gains of parallelization are asymptotic. You cannot continually add nodes and expect to improve performance.

In addition to the fact that adding more leaf nodes may not actually speed up processing, scatter/gather systems also suffer from the “straggler” problem, which you may have encountered in MapReduce big-data systems like Hadoop. To understand how this works, it is important to remember that in a scatter/gather system, the root node waits for requests from *all* of the leaf nodes to return before sending a response back to the end user. Since data from every leaf node is required, the overall time it takes to process a user request is defined by the slowest leaf node that sends a response. To understand the impact of this, imagine that we have a service that has a 99th percentile latency of 2 seconds. This means that on average one request out of every 100 has a latency of 2 seconds, or put another way,

there is a 1% chance that a request will take 2 seconds. This may be totally acceptable at first glance: a single user out of 100 has a slow request.

However, consider how this actually works in a scatter/gather system. Since the time of the user request is defined by the slowest response, we need to consider not a single request but all requests scattered out to the various leaf nodes.

Let's see what happens when we scatter out to five leaf nodes. In this situation, there is a 5% chance that one of these five scatter requests has a latency of 2 seconds ($0.99 \times 0.99 \times 0.99 \times 0.99 \times 0.99 = 0.95$). This means that our 99th percentile latency for individual requests becomes a 95th percentile latency for our complete scatter/gather system. And it only gets worse from there: if we scatter out to 100 leaves, then we are more or less guaranteeing that our overall latency for *all* requests will be 2 seconds.

Together, these complications of scatter/gather systems lead us to some conclusions:

- Increased parallelism doesn't always speed things up because of overhead on each node.
- Increased parallelism doesn't always speed things up because of the straggler problem.
- The performance of the 99th percentile is more important than in other systems because each user request actually becomes numerous requests to the service.

The same straggler problem applies to availability. If you issue a request to 100 leaf nodes, and the probability that any leaf node failing is 1 in 100, you are again practically guaranteed to fail every single user request.

Scaling Scatter/Gather for Reliability and Scale

Of course, just as with a sharded system, having a single replica of a sharded scatter/gather system is likely not the desirable design choice. A single replica means that if it fails, all scatter/gather requests will fail for the duration that the shard is unavailable because all requests are required to be processed by all leaf nodes in the scatter/gather pattern. Likewise, upgrades will take out a percentage of your shards, so an upgrade while under user-facing load is no longer possible. Finally, the computational scale of your system will be limited by the load that any single node is capable of achieving. Ultimately, this limits your scale, and as we have seen in previous sections, you cannot simply increase the number of shards in order to improve the computational power of a scatter/gather pattern.

Given these challenges of reliability and scale, the correct approach is to replicate each of the individual shards so that instead of a single instance at each leaf node, there is a replicated service that implements each leaf shard. This replicated sharded scatter/gather pattern is shown in [Figure 8-4](#).

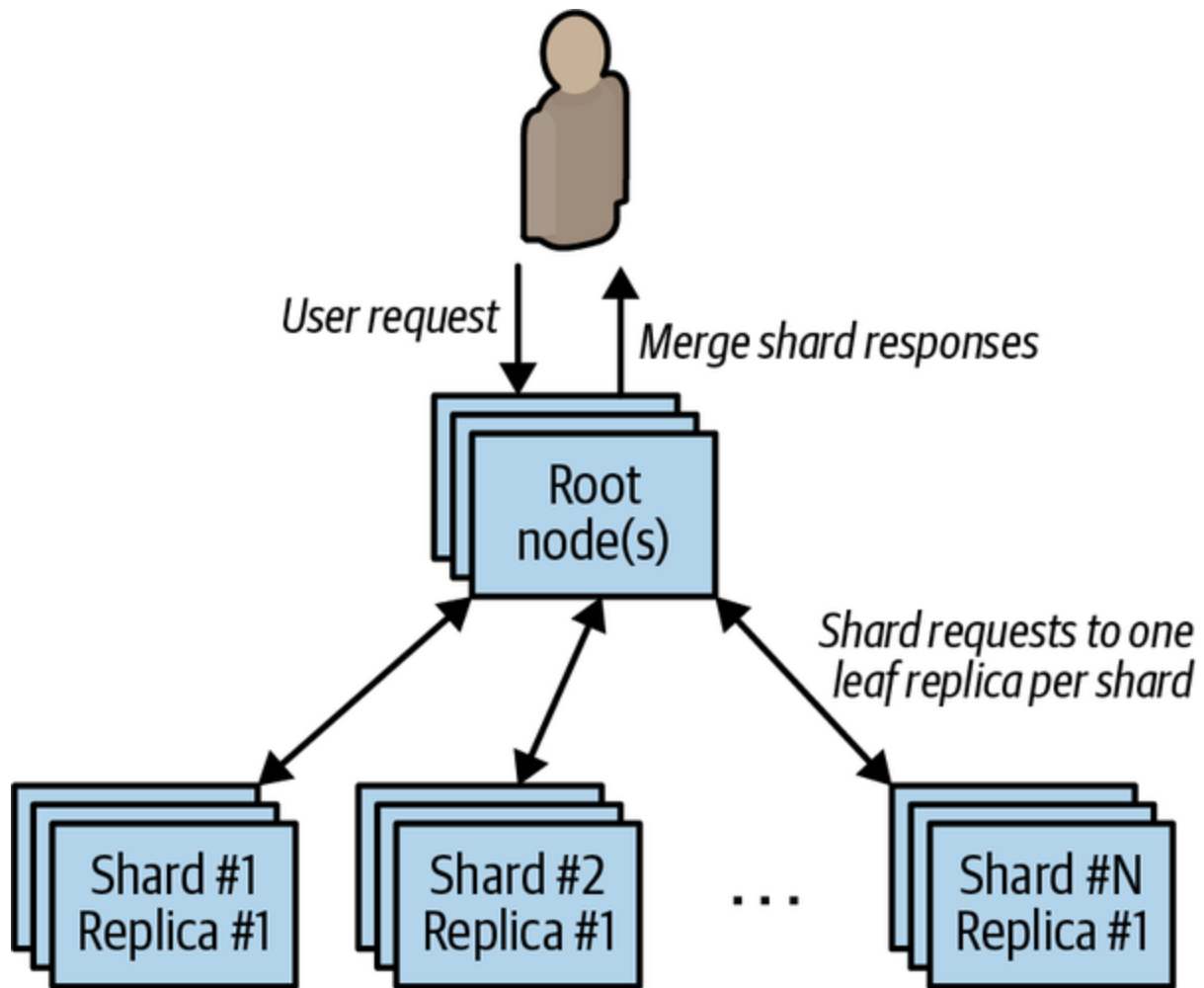

Figure 8-4. A sharded replicated scatter/gather system

Built this way, each leaf request from the root is actually load balanced across all healthy replicas of the shard. This means that if there are any failures, they won't result in a user-visible outage for your system. Likewise, you can safely perform an upgrade under load, since each replicated shard can be upgraded one replica at a time. Indeed, you can perform the upgrade across multiple shards simultaneously, depending on how quickly you want to perform the upgrade.

Summary

This chapter describes the scatter/gather pattern, a distributed system for improving computation speed and reducing the latency of handling any particular request. Whereas previous serving patterns focused on scaling for additional load or scaling for additional data, scatter/gather scales to increase responsiveness, to reduce the user-perceived time spent processing a request. We also saw how compute sharding with scatter/gather can be combined with data sharding for large indexes, as well as adding replication to improve reliability and redundancy. Any large-scale distributed system is often a combination of multiple different serving patterns.

Chapter 9. Functions and Event-Driven Processing

So far, we have examined design for systems with long-running computation. The servers that handle user requests are always up and running. This pattern is the right one for many applications that are under heavy load, keep a large amount of data in memory, or require some sort of background processing. However, there is a class of applications that might only need to temporarily come into existence to handle a single request, or simply need to respond to a specific event. This style of request or event-driven application design has flourished recently as large-scale public cloud providers have developed *function-as-a-service* (FaaS) products. More recently, FaaS implementations have also emerged running on top of cluster orchestrators in private cloud or physical environments. This chapter describes emerging architectures for this new style of computing. In many cases, FaaS is a component in a broader architecture rather than a complete solution.

NOTE

Oftentimes, FaaS is referred to as *serverless* computing. And while this is true (you don't see the servers in FaaS), it's worth differentiating between event-driven FaaS and the broader notion of serverless computing. Indeed, serverless computing can apply to a wide variety of computing services; for example, a multitenant container orchestrator (container-as-a-service) is serverless but not event-driven. Conversely, an open source FaaS running on a cluster of physical machines that you own and administer is event-driven but not serverless. Understanding this distinction enables you to determine when event-driven, serverless, or both is the right choice for your application.

Determining When FaaS Makes Sense

As with many tools for developing a distributed system, it can be tempting to see a particular solution like event-driven processing as a universal hammer. However, the truth is that it is best suited to a particular set of problems. Within a particular context it is a powerful tool, but stretching it to fit all applications or systems will lead to overly complicated, brittle designs. Especially since FaaS is a relatively new computing tool, before discussing specific design patterns, it is worth discussing the benefits, limitations, and optimal situations for employing event-driven computing.

The Benefits of FaaS

The benefits of FaaS are primarily for the developer. It dramatically simplifies the distance from code to running service. Because there is no artifact to create or push beyond the source code itself, FaaS makes it

simple to go from code on a laptop or web browser to running code in the cloud.

Likewise, the code that is deployed is managed and scaled automatically. As more traffic is loaded onto the service, more instances of the function are created to handle that increase in traffic. If a function fails due to application or machine failures, it is automatically restarted on some other machine.

Finally, much like containers, functions are an even more granular building block for designing distributed systems. Functions are stateless, and thus any system you build on top of functions is inherently more modular and decoupled than a similar system built into a single binary. But, of course, this is also the challenge of developing systems in FaaS. The decoupling is both a strength and a weakness. The following section describes some of the challenges that come from developing systems using FaaS.

The Challenges of FaaS

As described in [“The Benefits of FaaS”](#), developing systems using FaaS forces you to strongly decouple each piece of your service. Each function is entirely independent. The only communication is across the network, and each function instance cannot have local memory, requiring all states to be stored in a storage service. This forced decoupling can improve the agility

and speed with which you can develop services, but it can also significantly complicate the operations of the same service.

In particular, it is often quite difficult to obtain a comprehensive view of your service, determine how the various functions integrate with one another, and understand when things go wrong, and why they go wrong. Additionally, the request-based and serverless nature of functions means that certain problems are quite difficult to detect. As an example, consider the following functions:

- *functionA()* which calls *functionB()*
- *functionB()* which calls *functionC()*
- *functionC()* which calls back to *functionA()*

Now consider what happens when a request comes into any of these functions: it kicks off an infinite loop that only terminates when the original request times out (and possibly not even then) or when you run out of money to pay for requests in the system. Obviously, the above example is quite contrived, but it is actually quite difficult to detect in your code. Since each function is radically decoupled from the other functions, there is no real representation of the dependencies or interactions between different functions. These problems are not unsolvable, and I expect that as FaaS mature, more analysis and debugging tools will provide a richer experience to understand how and why an application comprised of FaaS is performing the way that it does.

For now, when adopting FaaS, you must be vigilant to adopt rigorous monitoring and alerting for how your system is behaving so that you can detect situations and correct them before they become significant problems. Of course, the complexity introduced by monitoring flies somewhat in the face of the simplicity of deploying to FaaS, which is friction that your developers must overcome.

The Need for Background Processing

FaaS is inherently an event-based application model. Functions are executed in response to discrete events that occur and trigger the execution of the functions. Additionally, because of the serverless nature of the implementation of these services, the runtime of any particular function instance is generally time bounded. This means that FaaS is usually a poor fit for situations that require processing. Examples of such background processing might be transcoding a video, compressing log files, or other sorts of low-priority, long-running computations. In many cases, it is possible to set up a scheduled trigger that synthetically generates events in your functions on a particular schedule. Though this is a good fit for responding to temporal events (e.g., firing a text-message alarm to wake someone up), it is still not sufficient infrastructure for generic background processing. To achieve that, you need to launch your code in an environment that supports long-running processes. And this generally

means switching to a pay-per-consumption rather than pay-per-request model for the parts of your application that do background processing.

The Need to Hold Data in Memory

In addition to the operational challenges, there are some architectural limitations that make FaaS ill-suited for some types of applications. The first of these limitations is the need to have a significant amount of data loaded into memory in order to process user requests. There are a variety of services (e.g., serving a search index of documents) that require a great deal of data to be loaded in memory in order to service user requests. Even with a relatively fast storage layer, loading such data can take significantly longer than the desired time to service a user request. Because with FaaS, the function itself may be dynamically spun up in response to a user request *while the user is waiting*, the need to load a lot of detail may significantly impact the latency that the user perceives while interacting with your service. Of course, once your FaaS has been created, it may handle a large number of requests, so this loading cost can be amortized across a large number of requests. But if you have a sufficient number of requests to keep a function active, then it's likely you are overpaying for the requests you are processing.

The Costs of Sustained Request-Based Processing

The cost model of public cloud FaaS is based on per-request pricing. This approach is great if you only have a few requests per minute or hour. In such a situation, you are idle most of the time, and given a pay-per-request model, you are only paying for the time when your service is actively serving requests. In contrast, if you service requests via a long-running service, either in a container or a virtual machine, then you are always paying for processor cycles that are largely sitting around waiting for a user request.

However, as a service grows, the number of requests that you are servicing grows to the point where you can keep a processor continuously active servicing user requests. At this point, the economics of a pay-per-request model start to become bad, and only get worse because the cost of cloud virtual machines generally decreases as you add more cores (and also via committed resources like reservations or sustained use discounts), whereas the cost per-request largely grows linearly with the number of requests.

Consequently, as your service grows and evolves, it's highly likely that your use of FaaS will evolve as well. One ideal way to scale FaaS is to run an open source FaaS that runs on a container orchestrator like Kubernetes. That way, you can still take advantage of the developer benefits of FaaS, while taking advantage of the pricing models of virtual machines.

Patterns for FaaS

In addition to understanding the trade-offs in deploying event-driven or FaaS architectures as part of your distributed system, understanding the best ways to deploy FaaS is critical to the design of a successful system. This section describes some canonical patterns for incorporating FaaS.

The Decorator Pattern: Request or Response Transformation

FaaS is ideal for deploying simple functions that can take an input, transform it into an output, and then pass it on to a different service. This general pattern can be used to augment or decorate HTTP requests to or from a different service. A basic illustration of this pattern is shown in [Figure 9-1](#).

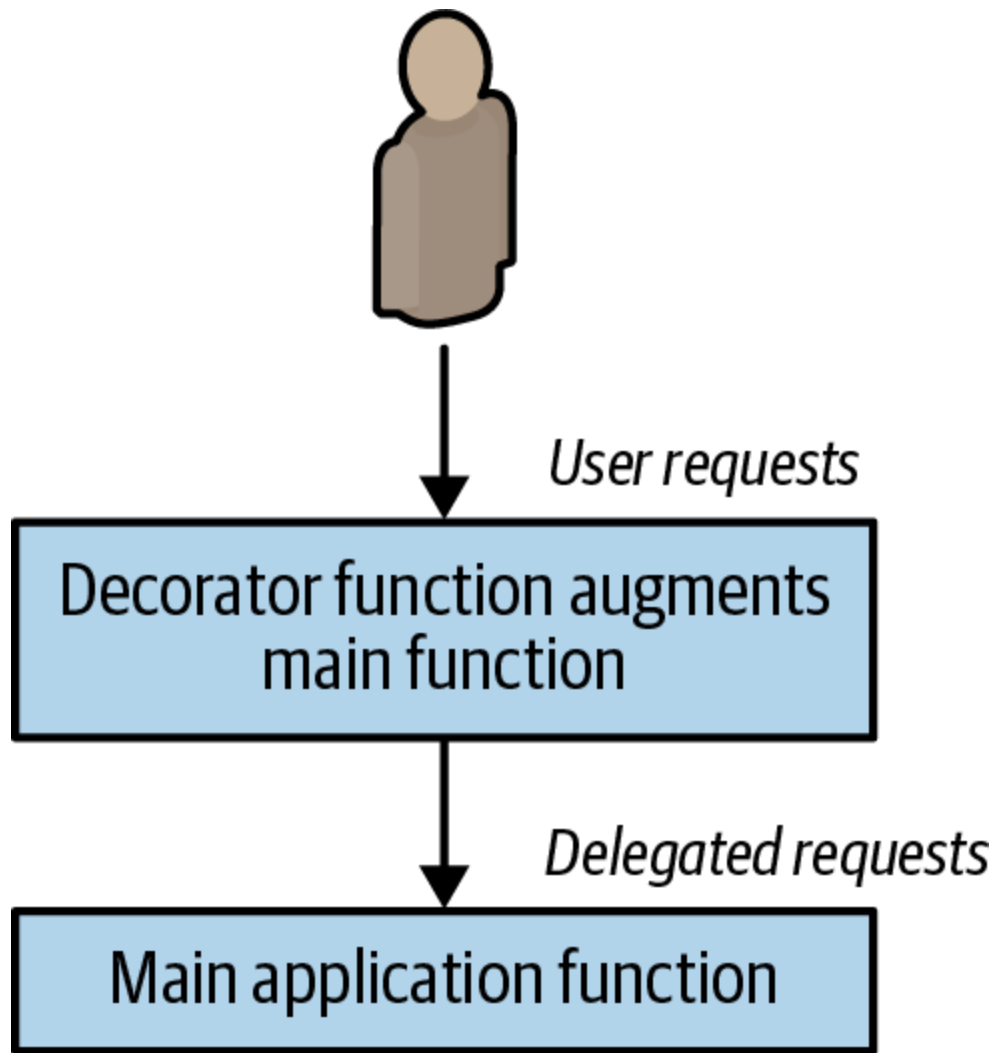

Figure 9-1. The decorator pattern applied to HTTP APIs

Interestingly, there are several analogies to this pattern in programming languages. In particular, the *decorator* pattern from Python is a close analogue for the services that a request or response decorator can perform. Because decoration transformations are generally stateless, and also because they are often added after the fact to existing code as the service evolves, they are ideal services to implement via FaaS. Additionally, the lightness of FaaS means that you can experiment with a variety of different

decorators before finally adopting one and pulling it more completely into the implementation of the service.

A great example of the value of the decorator pattern is adding defaults to the input to an HTTP RESTful API. In many cases in the API, there are fields whose values should have sane defaults if they are left empty. For example, you may want a field to default to `true`, but it's difficult to accomplish this in classical JSON, because the default value for a field is `null`, which is generally understood to be `false`. To resolve this, we can add defaulting logic either in the front of the API server or within the application code itself (e.g., `if (field == null) field = true`). However, both of these solutions are somewhat unappealing since the defaulting mechanism is fairly conceptually independent from the handling of the request. Instead, we can use the FaaS decorator pattern to transform the request in between the user and the service implementation.

Given the previous discussion of the adapter pattern in the single-node section, you may be wondering why we don't simply package this defaulting as an adapter container. And this is a totally reasonable approach, but it does mean that we are going to couple the scale of the defaulting service with the API service itself. The defaulting is actually a lightweight operation, and we are likely to need far fewer instances of it than the service itself to handle the load.

NOTE

For the examples in this chapter, we are going to use the [kubeless FaaS framework](#). Kubeless is deployed on top of the Kubernetes container orchestration service. Assuming that you have provisioned a Kubernetes cluster, you can install Kubeless from its [releases page](#). Once you have the `kubeless` binary installed, you can install it into your cluster with the following commands:

```
kubeless install.
```

Kubeless installs itself as a native Kubernetes third-party API. This means that once it is installed, you can use the native `kubectl` command-line tool. For example, you can see deployed functions using `kubectl get functions`. Currently, you should have no functions deployed.

Hands On: Adding Request Defaulting Prior to Request Processing

To demonstrate the utility of the decorator pattern for FaaS, consider the task of adding default values to a RESTful function call if the values are missing. This is quite straightforward to do using FaaS. We'll write the defaulting function using the Python programming language:

```
# Simple handler function for adding default values
def handler(context):
    # Get the input value
    obj = context.json
    # If the 'name' field is not present, set it to a random name
    if obj.get("name", None) is None:
        obj["name"] = random_name()
    # If the 'color' field is not present, set it to a random color
```

```
if obj.get("color", None) is None:
    obj["color"] = "blue"
# Call the actual API, potentially with the new
# values, and return the result
return call_my_api(obj)
```

Save this function in a file named *defaults.py*. You obviously will want to update the `call_my_api` code so that it points to the actual API you want to call. Once you have finished writing the code, this defaulting function can be installed as a `kubeless` function using:

```
kubeless function deploy add-defaults \
  --runtime python27 \
  --handler defaults.handler \
  --from-file defaults.py \
  --trigger-http
```

If you want to test the handling of this function, you can also use the `kubeless` tool:

```
kubeless function call add-defaults --data '{"name": "test"}
```

The decorator pattern shows just how easy it is to adapt and extend existing APIs with additional features like validation or defaulting.

Handling Events

While most systems are request-driven, handling a steady stream of user and API requests, many other systems are more event-driven in nature. The differentiation, in my mind at least, between a request and an event has to do with the notion of *session*. Requests are part of a larger series of interactions or sessions; generally each user request is part of a larger interaction with a complete web application or API. *Events*, as I see them, instead tend to be single-instance and asynchronous in nature. Events are important and need to be properly handled, but they are fired off from a main interaction and responded to some time later. Examples of events include a user signing up for a new service (which might trigger a welcome email), someone uploading a file to a shared folder (which might send notifications to everyone who has access to the folder), or even a machine being about to reboot (which might notify an operator or automated system to take appropriate action).

Because these events tend to be largely independent and stateless in nature, and because the rate of events can be highly variable, they are ideal candidates for event-driven and FaaS architectures. In this role, they are often deployed alongside a production application server as augmentation to the main user experience, or to handle some sort of reactive, background processing. Additionally, because new events are often dynamically added to the service, the lightweight nature of deploying functions is a good match for defining new event handlers. Likewise, because each event is

conceptually independent, the forced decoupling of a functions-based system actually helps *reduce* the conceptual complexity by enabling a developer to focus on the steps required to handle just a single type of event.

A concrete example of integrating an event-based component to an existing service is implementing two-factor authentication. In this case, the event is the user logging into a service. The service can generate an event for this action, fire it into a function-based handler that takes the code and the user's contact information, and sends the two-factor code via text message.

Hands On: Implementing Two-Factor Authentication

Two-factor authentication requires that the user both have something that they know (e.g., a password) as well as something that they possess (e.g., a phone) to be able to log in to the system. Two-factor authentication is significantly more secure than passwords alone since it requires two different security compromises (a thief learning your password *and* a thief stealing your phone) to enable a true security problem.

When considering how to implement two-factor authentication, one of the challenges is how to handle the request to generate a random code and register it with the login service as well as send the text message. It is possible to add this code to the main login web server. But it is complicated

and monolithic, and forces the act of sending a text message, which can have some latency, to be inline with the code that renders the login web page. This latency produces a substandard user experience.

A better option is to register a FaaS to asynchronously generate the random number, register it with the login service, and send the number to the user's phone. In this way, the login server can simply fire an asynchronous web-hook request to a FaaS, and that FaaS can handle the somewhat slow and asynchronous task of registering the two-factor code and sending the text message.

To see how this works in practice, consider the following code:

```
def two_factor(context):
    # Generate a random six-digit code
    code = random.randint(100000, 999999)

    # Register the code with the login service
    user = context.json["user"]
    register_code_with_login_service(user, code)

    # Use the twillio library to send texts
    account = "my-account-sid"
    token = "my-token"
    client = twilio.rest.Client(account, token)

    user number = context.json["phoneNumber"]
```

```
msg = "Hello {} your authentication code is: {}".format(
    message = client.api.account.messages.create(to=phone_number,
    from=phone_number, body=msg)

return {"status": "ok"}
```

We can then register this FaaS with `kubeless` :

```
kubeless function deploy add-two-factor \
  --runtime python27 \
  --handler two_factor.two_factor \
  --from-file two_factor.py \
  --trigger-http
```

This function can then be made asynchronously from client-side JavaScript whenever the user successfully provides their password. The web UX can then immediately display a page to enter the code, and the user (once they receive the code as a text message) can supply it to the service, where the code has already been registered via our FaaS.

Again, developing a simple, asynchronous, event-based service that is triggered whenever a user logs in is made dramatically simpler using FaaS.

Event-Based Pipelines

There are some applications that are inherently easier to think about in terms of a pipeline of decoupled events. These event pipelines often resemble the flowcharts of old. They can be represented as a directed graph of connected event syncs. In the event pipeline pattern, each node is a different function or webhook, and the edges linking the graph together are HTTP or other network calls to the function/webhook. In general, there is no shared state between the different pieces of the pipeline, but there may be a context or other reference point that can be used to look up information in shared storage.

So, what is the difference between this type of pipeline and a “microservices” architecture? There are two central differences. The first is the main difference between functions in general and long-running services, which is that an event-based pipeline is by its very nature event-driven. Conversely, a microservices architecture features a collection of long-running services. Additionally, event-driven pipelines may be highly asynchronous and diverse in the things that they connect together. For example, while it is difficult to see how a human approving a ticket in a ticketing system like Jira could be integrated into a microservices application, it’s quite easy to see how that event could be incorporated into an event-driven pipeline.

As an example of this, imagine a pipeline in which the original event is code being submitted into a source control system. This event then triggers a build. The build may take multiple minutes to complete, and when it does,

it fires an event to a build analysis function. This function takes different actions if the build is successful or fails. If the build succeeds, a ticket is created for a human to approve it to be pushed to production. Once the ticket is closed, the act of closing is an event that triggers the actual push to production. If the build fails, a bug is filed on the failure, and the event pipeline terminates.

Hands On: Implementing a Pipeline for New User Signup

Consider the task of implementing a new user signup flow. When a new user account is created, there are certain things that are always done, such as sending a welcome email. And there are some things that are optionally done, such as registering a user to receive product updates (sometimes known as “spam”) via their email.

One approach to implementing this logic would be to place everything into a single monolithic *user-creation* server. However, this factoring means that a single team owns the entirety of the user-creation service, and that the entire experience is deployed as a single service. Both of these mean that it is more difficult to perform experiments or make changes to the user experience.

Consider, instead, implementing the user login experience as an event pipeline with a series of FaaS. In this factoring, the user-creation function is

actually unaware of the details of what happens on user login. Instead, the main user-creation service simply has two lists:

- A list of required actions (e.g., sending a welcome mail)
- A list of optional actions (e.g., subscribing the user to a mailing list)

Each of these actions is also implemented as a FaaS, and the list of actions is actually just a list of webhooks. Consequently, the main user creation function looks like this:

```
def create_user(context):
    # For required event handlers, call them unconditionally
    for key, value in required.items():
        call_function(value.webhook, context.json)

    # For optional event handlers, check and call them
    # conditionally
    for key, value in optional.items():
        if context.json.get(key, None) is not None:
            call_function(value.webhook, context.json)
```

Now we can also use FaaS to implement each of these handlers:

```
def email_user(context):
    # Get the user name
    user = context.json['username']
```

```
msg = 'Hello {} thanks for joining my awesome s  
send_email(msg, contex.json['email'])
```

```
def subscribe_user(context):  
    # Get the user name  
    email = context.json['email']  
    subscribe_user(email)
```

Factored in this way, each FaaS is simple, containing only a few lines of code and focused on implementing one specific piece of functionality. This microservices-based approach is simple to write but might lead to complexity if we actually had to deploy and manage three different microservices. This is where FaaS can shine, since it makes it trivially easy to host these small code snippets. Additionally, by visualizing our user-creation flow as an event-driven pipeline, it is also straightforward to have a high-level understanding of what exactly happens on user login, simply by following the flow of the context through the various functions in the pipeline.

Summary

Functions as a service, or FaaS, is a powerful tool for easily hosting simple, scalable applications. As with any tool, the key to using it for maximal value lies in understanding what it is best at. The simplicity of functions as a service comes with restrictions that may limit ways in which your application can develop or libraries that your application can use. However, FaaS can also radically reduce your time to market. As you gain experience with distributed systems, you will see that the ideal design is often a combination of different pieces. Combining FaaS with more flexible infrastructure or IaaS primitives, like the core of the Kubernetes API, often allows you to gain the best of both possible worlds and blend power and flexibility with simplicity and automation for the optimal system design.

Chapter 10. Ownership Election

The previous patterns that we have seen have been about distributing requests in order to scale requests per second, the state being served, or the time to process a request. This final chapter on multinode serving patterns is about how you scale assignment. In many different systems, there is a notion of *ownership* where a specific process owns a specific task. We have previously seen this in the context of sharded and hot-sharded systems where specific instances owned specific sections of the sharded key space.

In the context of a single process on a single server, you have likely already learned how to manage concurrency using primitives like *locks* or *mutexes* that are present in modern programming languages. A lock establishes ownership within the context of a single application running on a single machine because it uses storage in the memory of that machine and primitives in the processor and operating system to establish exclusive access. Even in the context of a single machine, concurrency can be challenging to implement, and mistakes in concurrency are at the root of some of the most challenging bugs you may encounter.

Unfortunately, restricting ownership to a single application limits scalability, since the task can't be replicated, and reliability, since if the task fails, it is unavailable for a period of time. If you want to build a large-scale reliable system that requires ownership, you need to build distributed locks.

Distributed locks introduce additional complexity since you cannot rely on shared memory or processors between different containers in your distributed system.

A general diagram of distributed ownership is shown in [Figure 10-1](#). In the diagram, there are three replicas that could be the owner or leader. Initially, the first replica is the leader. Then that replica fails, and replica number three then becomes the leader. Finally, replica number one recovers and returns to the group, but replica three remains as the leader/owner.

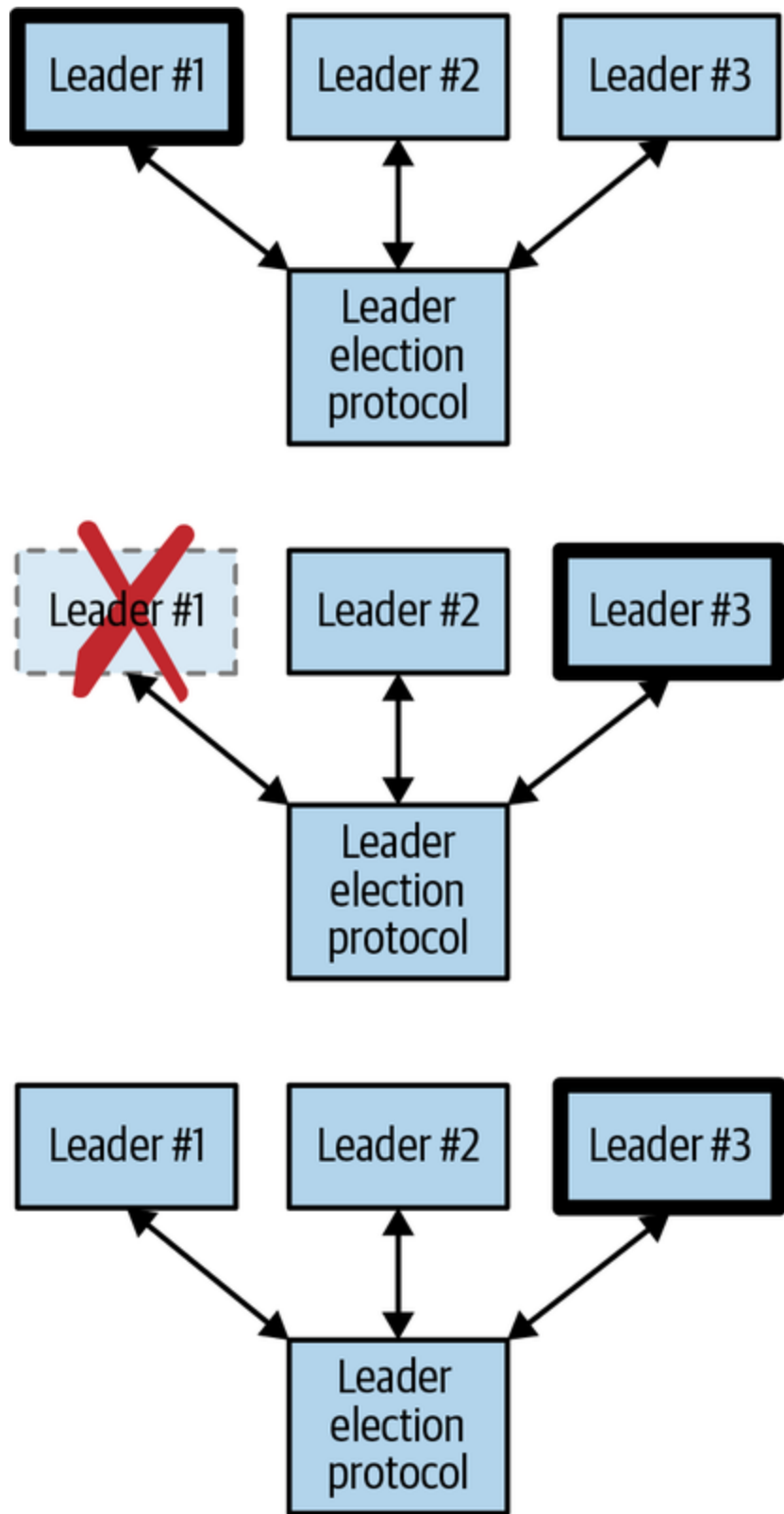

Figure 10-1. A leader election protocol in operation: initially the first leader is selected, but when it fails, the third leader takes over

Often, establishing distributed ownership is both the most complicated and most important part of designing a reliable distributed system.

Determining If You Even Need Leader Election

The simplest form of ownership is to just have a single replica of the service. Since there is only one instance running at a time, that instance implicitly owns everything without any need for election. This has advantages of simplifying your application and deployment, but it has disadvantages in terms of downtime and reliability. However, for many applications, the simplicity of this singleton pattern may be worth the reliability trade-off. Let's look at this further.

Assuming that you run your singleton in a container orchestration system like Kubernetes, you have the following guarantees:

- If the container crashes, it will automatically be restarted.
- If the container hangs, and you implement a health check, it will automatically be restarted.
- If the machine fails, the container will be moved to a different machine.

Because of these guarantees, a singleton of a service running in a container orchestrator has pretty good uptime. To take the definition of “pretty good”

a little further, let's examine what happens in each of these failure modes. If the container process fails or the container hangs, your application will be restarted in a few seconds. Assuming your container crashes once a day, this is roughly three to four nines of uptime (2 seconds of downtime / day \approx 99.99% uptime). If your container crashes less often, it's even better than that. If your machine fails, it takes a while for Kubernetes to decide that the machine has failed and move your workload over to a different machine; let's assume that takes around 5 minutes. Given that, if every machine in your cluster fails every day, then your service will have two nines of uptime. And honestly, if every machine in your cluster fails every day, then you have way worse problems than the uptime of your leader-elected service.

It's worth considering, of course, that there are more reasons for downtime than just failures. When you are rolling out new software, it takes time to download and start the new version. With a singleton, you cannot have both old and new versions running at the same time, so you will need to take down the old version for the duration of the upgrade, which may be several minutes if your image is large. Consequently, if you deploy daily and it takes two minutes to upgrade your software, you will only be able to run a two nines service, and if you deploy hourly, it won't even be a single nine service. Of course, there are ways that you can speed up your deployment by pre-pulling the new image onto the machine before you run the update. This can reduce the time it takes to deploy a new version to a few seconds,

but the trade-off is added complexity, which was what we were trying to avoid in the first place.

Regardless, there are many applications (e.g., background asynchronous processing) where such an SLA is an acceptable trade-off for application simplicity. One of the key components of designing a distributed system is deciding when the “distributed” part is actually unnecessarily complex. But there are certainly situations where high availability (four+ nines) is a critical component of the application, and in such systems, you need to run multiple replicas of the service, where only one replica is the designated owner. The design of these types of systems is described in the sections that follow.

The significant downside of just using a singleton is that for the period that the leader is down, your entire application will be unable to process requests. While you may be able to achieve a reasonable uptime measured across a day, for the seconds or minutes that you might be down, your service is completely down. For a system which is interactive, like a game, retail, or banking system, being completely down even for a short period of time will likely lead to significant customer dissatisfaction.

The Basics of Leader Election

Imagine that there is a service *Foo* with three replicas: *Foo-1*, *Foo-2*, and *Foo-3*. There is also some object *Bar* that must only be “owned” by one of the replicas (e.g., *Foo-1*) at a time. Often this replica is called the *leader*, hence the term *leader election* used to describe the process of how this leader is selected as well as how a new leader is selected if that leader fails.

There are two ways to implement this leader election. This first is to implement a distributed consensus algorithm like Paxos or RAFT, but the complexity of these algorithms make them beyond the scope of this book and not worthwhile to implement. Implementing one of these algorithms is akin to implementing locks on top of assembly code compare-and-swap instructions. It’s an interesting exercise for an undergraduate computer science course, but it is not something that is generally worth doing in practice.

Fortunately, there are a large number of distributed key-value stores that have implemented such consensus algorithms for you. At a general level, these systems provide a replicated, reliable data store and the primitives necessary to build more complicated locking and election abstractions on top. Examples of these distributed stores include etcd, ZooKeeper, and Consul. The basic primitives that these systems provide is the ability to perform a compare-and-swap operation for a particular key. Compare-and-swap atomically writes a new value if the existing value matches the expected value. If the value doesn’t match, it returns `false`. If the value doesn’t exist and `currentValue` is not null, it returns an error. If you

haven't seen compare-and-swap before, it is basically an atomic operation that looks like this:

```
lock := sync.Mutex{}
store := map[string]string{}

func compareAndSwap(key, nextValue, currentValue
    lock.Lock()
    defer lock.Unlock()
    _, containsKey := store[key]
    if !containsKey {
        if len(currentValue) == 0 {
            store[key] = nextValue
            return true, nil
        }
        return false, fmt.Errorf(
            "Expected value %s for key %s, but found er
    }
    if store[key] == currentValue {
        store[key] = nextValue
        return true, nil
    }
    return false, nil
}
```

In addition to compare-and-swap, the key-value stores allow you to set a time-to-live (TTL) for a key. Once the TTL expires, the key is set back to empty.

Put together, these functions are sufficient to implement a variety of distributed synchronization primitives.

Hands On: Deploying etcd

`etcd` is a distributed lock server originally developed by CoreOS and now donated to the [Cloud Native Computing Foundation \(CNCF\)](#) and maintained by the community. It is robust and proven in production at high scale, and is used by a variety of projects, including Kubernetes.

The easiest way to run `etcd` is to run it locally. The project makes available binaries for Linux, MacOS X, and Windows. You can [download those binaries from GitHub](#); version 3.5.16 was the latest at the time of writing, but you may want to check for later versions.

Once you have downloaded the archive for the release, you can unpack it, and you will find three executable binaries, `etcd`, `etcdctl`, and `etcdutl`, as well as some documentation. For the purposes of this exercise, you can just run `etcd` locally by running the command `etcd`; this will start `etcd` running on localhost (127.0.0.1).

Obviously, running `etcd` locally is not a very robust or permanent solution. If you would rather, you can run `etcd` inside a Kubernetes cluster using the open source package manager Helm. If you don't already have Helm installed, [you can do so from the Helm website](#).

Once you have the `helm` tool installed in your environment, you can install the `etcd` operator using `helm`, as follows:

```
# Initialize helm
helm init

# Install etcd using helm
helm install my-release oci://registry-1.docker...
```

Once the `etcd` chart is installed, you can use `kubectl get pods` to see the replicas in your `etcd` cluster.

Implementing Locks

The simplest form of synchronization is the mutual exclusion lock (a.k.a. mutex). Anyone who has done concurrent programming on a single machine is familiar with locks, and the same concept can be applied to distributed replicas. Instead of local memory and assembly instructions, these distributed locks can be implemented in terms of the distributed key-value stores described previously.

As with locks in memory, the first step is to acquire the lock:

```
func (Lock l) simpleLock() boolean {
    // compare and swap "1" for "0"
    locked, _ = compareAndSwap(l.lockName, "1", "0")
    return locked
}
```

But of course, it's possible that the lock doesn't already exist, because we are the first to claim it, so we need to handle that case, too:

```
func (Lock l) simpleLock() boolean {
    // compare and swap "1" for "0"
    locked, error = compareAndSwap(l.lockName, "1", "0")
    // lock doesn't exist, try to write "1" with a
    // non-existent
    if error != nil {
        locked, _ = compareAndSwap(l.lockName, "1", "0")
    }
    return locked
}
```

Traditional lock implementations block until the lock is acquired, so we actually want something like this:

```
func (Lock l) lock() {
    while (!l.simpleLock()) {
        sleep(2)
    }
}
```

This implementation, though simple, has the problem that you will always wait at least a second after the lock is released before you acquire the lock. Fortunately, many key-value stores let you watch for changes instead of polling, so you can implement:

```
func (Lock l) lock() {
    while (!l.simpleLock()) {
        waitForChanges(l.lockName)
    }
}
```

Given this locking function, we can also implement unlock:

```
func (Lock l) unlock() {
    compareAndSwap(l.lockName, "0", "1")
}
```

You might now think that we are done, but remember that we are building this for a distributed system. A process could fail in the middle of holding

the lock, and at that point there is no one left to release it. In such a situation, our system will become stuck. To resolve this, we take advantage of the TTL functionality of the key-value store. We change our `simpleLock` function so that it always writes with a TTL, so if we don't unlock within a given time, the lock will automatically unlock:

```
func (Lock l) simpleLock() boolean {
    // compare and swap "1" for "0"
    locked, error = compareAndSwap(l.lockName, "1", "0")
    // lock doesn't exist, try to write "1" with a TTL
    // non-existent

    if error != nil {
        locked, _ = compareAndSwap(l.lockName, "1", "0", l.ttl)
    }
    return locked
}
```

NOTE

When using distributed locks, it is critical to ensure that any processing you do doesn't last longer than the TTL of the lock. One good practice is to set a watchdog timer when you acquire the lock. The watchdog contains an assertion that will crash your program if the TTL of the lock expires before you have called `unlock`. If you don't do this, you may perform computation when you have lost the lock.

By adding TTL to our locks, we have actually introduced a bug into our `unlock` function. Consider the following scenario:

1. Process-1 obtains the lock with TTL t .
2. Process-1 runs really slowly for some reason, for longer than t .
3. The lock expires.
4. Process-2 acquires the lock, since Process-1 has lost it due to TTL.
5. Process-1 finishes and calls `unlock`.
6. Process-3 acquires the lock.

At this point, Process-1 believes that it has unlocked the lock that it held at the beginning; it doesn't understand that it has actually lost the lock due to TTL, and in fact unlocked the lock held by Process-2. Then Process-3 comes along and also grabs the lock. Now both Process-2 and Process-3 believe they own the lock, which means that your system likely has unexpected failures or data corruption.

Fortunately, the key-value store provides a *resource version* for every write that is performed. Whenever a new write is performed, the resource version changes. We can use this resource version as a precondition for any subsequent write to ensure ordering. Our lock function stores the resource version and uses it in `compareAndSwap` to ensure that not only is the value as expected, but the resource version is the same as when the lock operation occurred. This changes our simple `LOCK` function to look like this:

```
func (Lock l) simpleLock() boolean {
    // compare and swap "1" for "0"
    locked, l.version, error = compareAndSwap(l.lockName, "0", "1", l.version)
    // lock doesn't exist, try to write "1" with a
    // non-existent
    if error != null {
        locked, l.version, _ = compareAndSwap(l.lockName, "0", "1", l.version)
    }
    return locked
}
```

And the `unlock` function then looks like this:

```
func (Lock l) unlock() {
    compareAndSwap(l.lockName, "1", "0", l.version)
}
```

This ensures that the lock is only unlocked if the TTL has not expired. The lock cannot be unlocked accidentally if someone else has acquired it after the TTL expired. In such a case, the new owner of the lock has to have written a value into the storage system which results in a new resource version, and our attempt to unlock using the old resource version will fail.

Hands On: Implementing Locks in etcd

To implement locks in `etcd`, you can use a key as the name of the lock and pre-condition writes to ensure that only one lock holder is allowed at a time. For simplicity, we'll use the `etcdctl` command line to lock and unlock the lock. In reality, of course, you would want to use a programming language; there are `etcd` clients for most popular programming languages.

Let's start by creating a lock named `my-lock`:

```
kubectl exec my-etcd-cluster-0000 -- sh -c \  
  "ETCD_API=3 etcdctl --endpoints=${ETCD_ENDPOINTS} set --swap-with-value unlocked my-lock"
```

This creates a key in `etcd` named `my-lock` and sets the initial value to `unlocked`.

Now let's suppose that Alice and Bob both want to take ownership of `my-lock`. Alice and Bob both try to write their name to the lock, using a precondition that the value of the lock is `unlocked`.

Alice first runs:

```
kubectl exec my-etcd-cluster-0000 -- sh -c \  
  "ETCD_API=3 etcdctl --endpoints=${ETCD_ENDPOINTS} set --swap-with-value unlocked my-lock alice"
```

And obtains the lock. Now Bob attempts to obtain the lock:

```
kubectl exec my-etcd-cluster-0000 -- sh -c \  
  "ETCD_API=3 etcdctl --endpoints=${ETCD_ENDPOINTS} \  
    set --swap-with-value unlocked my-lock bob \  
Error: 101: Compare failed ([unlocked != alice])"
```

You can see that Bob's attempt to claim the lock has failed, since Alice currently owns the lock.

To unlock the lock, Alice writes `unlocked` with a precondition value of `alice`:

```
kubectl exec my-etcd-cluster-0000 -- sh -c \  
  "ETCD_API=3 etcdctl --endpoints=${ETCD_ENDPOINTS} \  
    set --swap-with-value alice my-lock unlocked"
```

Implementing Ownership

While locks are great for establishing temporary ownership of some critical component, sometimes you want to take ownership for the duration of the time that the component is running. For example, in a highly available deployment of Kubernetes, there are multiple replicas of the scheduler but only one replica is actively making scheduling decisions. Further, once it

becomes the active scheduler, it remains the active scheduler until that process fails for some reason.

Obviously, one way to do this would be to extend the TTL for the lock to a very long period (say a week or longer), but this has the significant downside that if the current lock owner fails, a new lock owner wouldn't be chosen until the TTL expired a week later.

Instead, we need to create a *renewable lock*, which can be periodically renewed by the owner so that the lock can be retained for an arbitrary period of time.

We can extend the existing `LOCK` that we defined previously to create a *renewable lock*, which enables the lock holder to renew the lock:

```
func (Lock l) renew() boolean {
    locked, _ = compareAndSwap(l.lockName, "1", "1")
    return locked
}
```

Of course, you probably want to do this repeatedly in a separate thread so that you hold onto the lock indefinitely. Notice that the lock is renewed every `tTTL/2` seconds; that way there is significantly less risk that the lock will accidentally expire due to timing subtleties:

```
for {
  if !l.renew() {
    handleLockLost()
  }
  sleep(ttl/2)
}
```

Of course, you need to implement the `handleLockLost()` function so that it terminates all activity that required the lock in the first place. In a container orchestration system, the easiest way to do this may simply be to terminate the application and let the orchestrator restart it. This is safe, because some other replica has grabbed the lock in the interim, and when the restarted application comes back online it will become a secondary listener waiting for the lock to become free.

Hands On: Implementing Leases in etcd

To see how we implement leases using `etcd`, we will return to our earlier locking example and add the `--ttl=<seconds>` flag to our lock create and update calls. The `ttl` flag defines a time after which the lock that we create is deleted. Because the lock disappears after the `ttl` expires, instead of creating with the value of `unlocked`, we will assume that the absence of the lock means that it is unlocked. To do this, we use the `mk` command instead of the `set` command. `etcdctl mk` only succeeds if the key does *not* currently exist.

Thus, to lock a leased lock, Alice executes:

```
kubectl exec my-etcd-cluster-0000 -- \
  sh -c "ETCD_API=3 etcdctl --endpoints=${ETCD_
    --ttl=10 mk my-lock alice"
```

This creates a leased lock with a duration of 10 seconds.

For Alice to continue to hold the lock, she needs to execute:

```
kubectl exec my-etcd-cluster-0000 -- \
  sh -c "ETCD_API=3 etcdctl --endpoints=${ETCD_
    set --ttl=10 --swap-with-value alice my-"
```

It may seem odd that Alice is continually rewriting her own name into the lock, but this is the way the lock lease is extended beyond the 10-second TTL.

If, for some reason, the TTL expires, then the lock update will fail, and Alice will go back to creating the lock using the `etcd mk` command, or Bob may also use the `mk` command to obtain the lock for himself. Bob will likewise need to set and update the lock every 10 seconds to maintain ownership.

Handling Concurrent Data Manipulation

Even with all of the locking mechanisms we have described, it is still possible for two replicas to simultaneously believe they hold the lock for a very brief period of time. To understand how this can happen, imagine that the original lock holder becomes so overwhelmed that its processor stops running for minutes at a time. This can happen on extremely overscheduled machines. In such a case, the lock will time out and some other replica will own the lock. Now the processor frees up the replica that was the original lock holder. Obviously, the `handleLockLost()` function will quickly be called, but there will be a brief period where the replica still believes it holds the lock. Although such an event is fairly unlikely, systems need to be built to be robust to such occurrences. The first step to take is to double-check that the lock is still held, using a function like this:

```
func (Lock l) isLocked() boolean {  
    return l.locked && l.lockTime + 0.75 * l.ttl >  
}
```

If this function executes prior to any code that needs to be protected by a lock, then the probability of two leaders being active is significantly reduced, but—it is important to note—it is not completely eliminated. The lock timeout could always occur between the time that the lock was checked and the guarded code was executed. To protect against these

scenarios, the system that is being called from the replica needs to validate that the replica sending a request is actually still the leader. To do this, the hostname of the replica holding the lock is stored in the key-value store in addition to the state of the lock. That way, others can double-check that a replica asserting that it is the leader is in fact the leader.

This system diagram is shown in [Figure 10-2](#). In the image, `shard2` is the owner of the lock, and when a request is sent to the worker, the worker double-checks with the lock server and validates that `shard2` is actually the current owner.

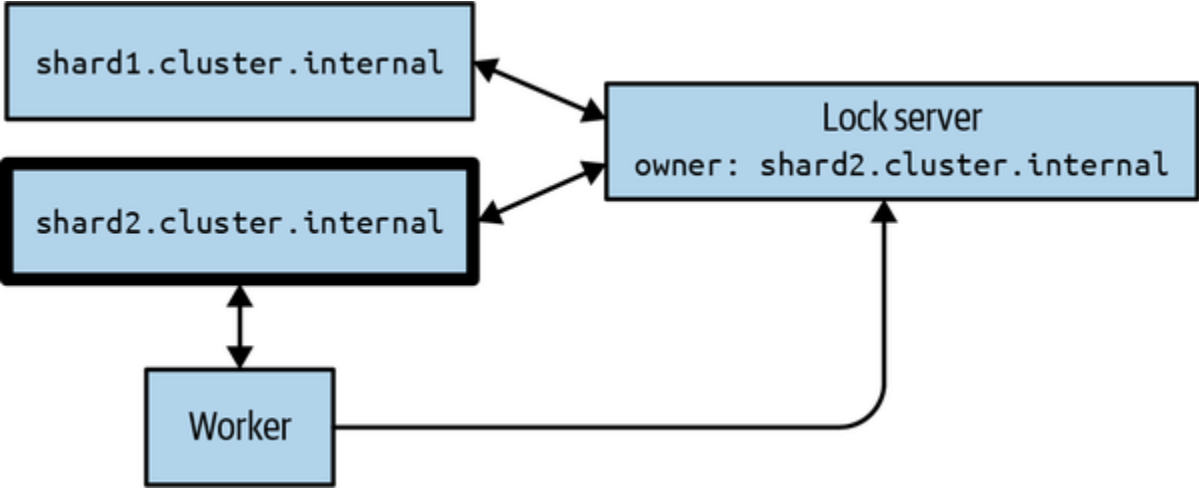

Figure 10-2. A worker double-checking to validate that the requester who sent a message is actually the current owner of the shard

In the second case, `shard2` has lost ownership of the lock, but it has not yet realized this, so it continues to send requests to the worker node. This time, when the worker node receives a request from `shard2`, it double-

checks with the lock service and realizes that `shard2` is no longer the lock owner, and thus the requests are rejected.

To add one final further complicating wrinkle, it's always possible that ownership could be obtained, lost, and then re-obtained by the system, which could actually cause a request to succeed when it should actually be rejected. To understand how this is possible, consider the following sequence of events:

1. `shard1` obtains ownership to become leader.
2. `shard1` sends a request `R1` as leader at time `T1`.
3. The network hiccups and delivery of `R1` is delayed.
4. `shard1` fails TTL because of the network and loses lock to `shard2`.
5. `shard2` becomes leader and sends a request `R2` at time `T2`.
6. Request `R2` is received and processed.
7. `shard2` crashes and loses ownership back to `shard1`.
8. Request `R1` finally arrives, and `shard1` is the current leader, so it is accepted, but this is bad because `R2` has already been processed.

Such sequences of events seem byzantine, but in reality, in any large system they occur with disturbing frequency. Fortunately, this is similar to the case described previously, which we resolved with the resource version in `etcd`. We can do the same thing here. In addition to storing the name of the current owner in `etcd`, we also send the resource version along with each request. So in the previous example, `R1` becomes `(R1,`

Version1) . Now when the request is received, the double-check validates both the current owner *and* the resource version of the request. If either match fails, the request is rejected. This patches up this example.

Ultimately, in designing a distributed ownership system, you have to choose between at-most once processing, which is possible, but requires you to possibly lose availability for a period of time. Or you can have at least once processing, which can provide higher availability, but will occasionally result in double processing of some request. Depending on the type of system you are building, duplicate processing may simply waste some resources (e.g., compute time on a GPU); in which case, if it is infrequent, it is likely acceptable. However, some systems may involve actual transactions (e.g., transferring money between accounts) where you would rather lose availability but preserve consistency. Understanding these trade-offs is a critical part of distributed system design.

Summary

In this chapter we have explored one of the most complicated parts of distributed system design, distributed ownership and locks. While parallel concurrent processing is a key part of building reliable, scalable systems, the concurrency also introduces challenges in systems where ownership of specific work is important. Distributed ownership or locks enable pieces of your distributed system to maintain exclusive access to a particular part of

the data store or compute operations. Implementing locks involves interacting with consensus-based distributed storage, like `etcd` or ZooKeeper, with very specific coding patterns. In many languages, code for distributed locks have already been implemented. Since writing this code yourself is a challenge, if there's already a library for your programming language, it's a best practice to rely on pre-existing production-grade code. Finally, some simple systems don't need locks and can get away with using Singletons and in-process concurrency. Such systems trade availability for simplicity.

Part IV. Batch Computational Patterns

The preceding chapters described patterns for reliable, long-running server applications. This section describes patterns for batch processing. In contrast to long-running applications, batch processes are expected to only run for a short period of time. Examples of a batch process include generating aggregation of user telemetry data, analyzing sales data for daily or weekly reporting, or transcoding video files. Batch processes are generally characterized by the need to process large amounts of data quickly using parallelism to speed up the processing. The most famous pattern for distributed batch processing is the MapReduce pattern, which has become an entire industry in itself. However, there are several other patterns that are useful for batch processing, which are described in the following chapters.

Chapter 11. Work Queue Systems

The simplest form of batch processing is a *work queue*. In a work queue system, there is a batch of work to be performed. Each piece of work is wholly independent of the other and can be processed without any interactions. Generally, the goals of the work queue system are to ensure that each piece of work is processed within a certain amount of time. Workers are scaled up or scaled down to ensure that the work can be handled. An illustration of a generic work queue is shown in [Figure 11-1](#).

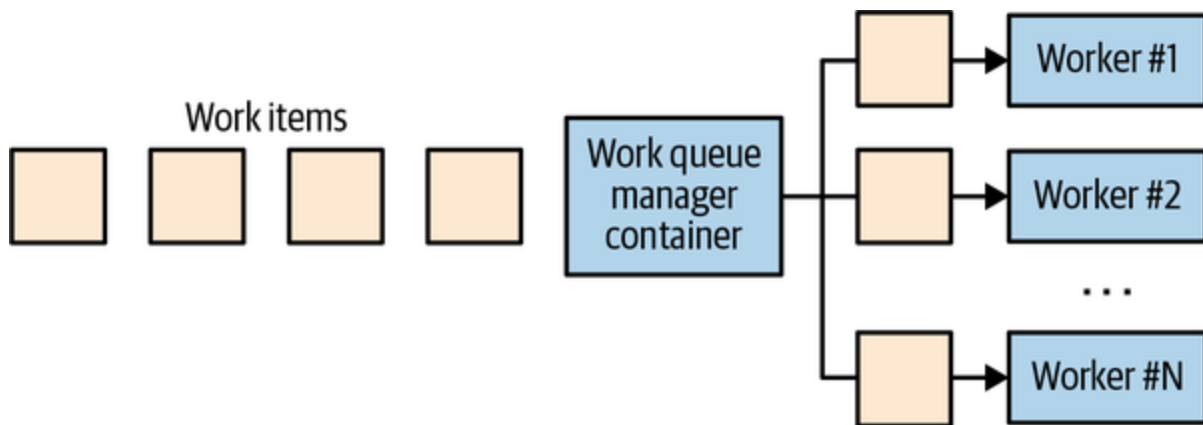

Figure 11-1. A generic work queue

A Generic Work Queue System

The work queue is an ideal way to demonstrate the power of distributed system patterns. Most of the logic in the work queue is wholly independent of the actual work being done, and in many cases the delivery of the work can be performed in an independent manner as well. To illustrate this point,

consider the work queue illustrated in [Figure 11-1](#). If we take a look at it again and identify functionality that can be provided by a shared set of *library containers*, it becomes apparent that most of the implementation of a containerized work queue can be shared across a wide variety of users, as shown in [Figure 11-2](#).

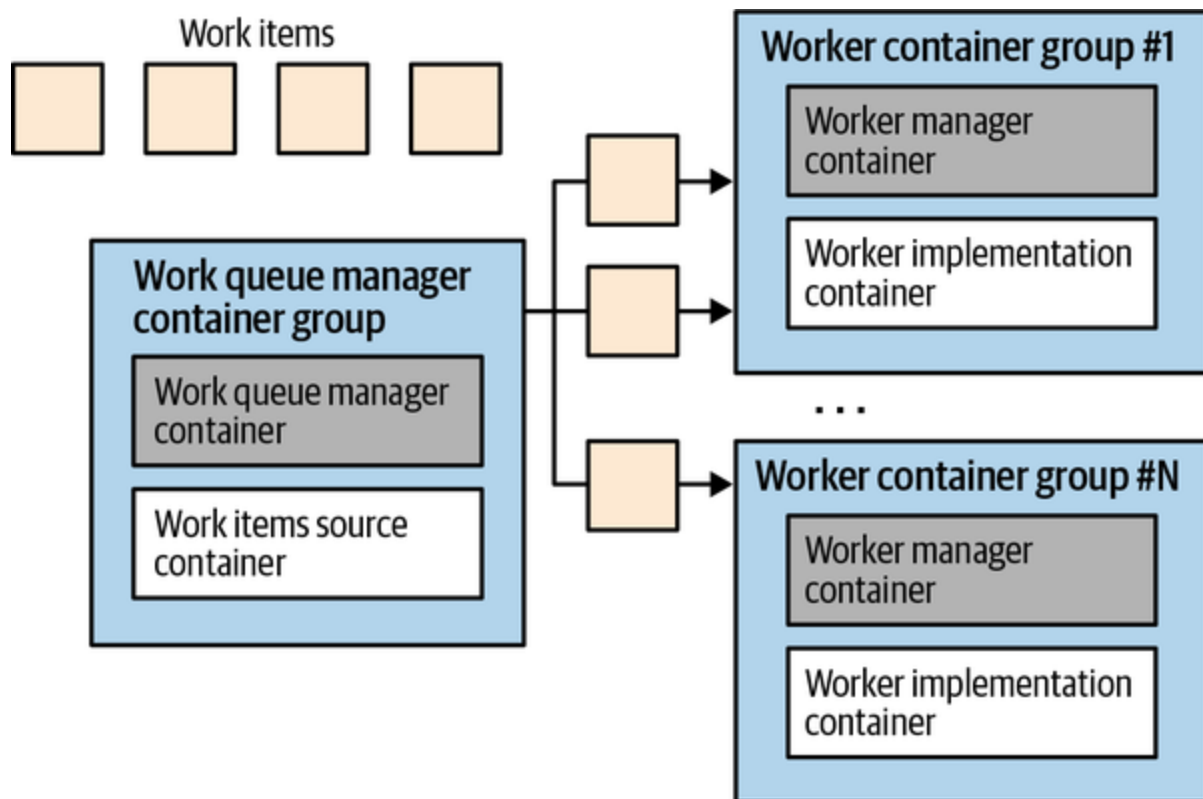

Figure 11-2. The same work queue as shown in [Figure 11-1](#), but this time using reusable containers; the reusable system containers are shown in white, while the user-supplied container is shown in the darker shaded boxes

Building a reusable container-based work queue requires the definition of interfaces between the generic library containers and the user-defined application logic. In the containerized work queue, there are two interfaces: the source container interface, which provides a stream of work items that

need processing, and the worker container interface, which knows how to actually process a work item.

The Source Container Interface

To operate, every work queue needs a collection of work items that need processing. There are many different sources of work items for the work queue, depending on the specific application of the work queue. However, once the set of items has been obtained, the actual operation of the work queue is quite generic. Consequently, we can separate the application-specific queue source logic from the generic queue processing logic. Given the previously defined patterns of container groups, this can be seen as an example of the ambassador pattern defined previously. The generic work queue container is the primary application container, and the application-specific source container is the ambassador that proxies the generic work queue's requests out to the concrete definition of the work queue out in the real world. This container group is illustrated in [Figure 11-3](#).

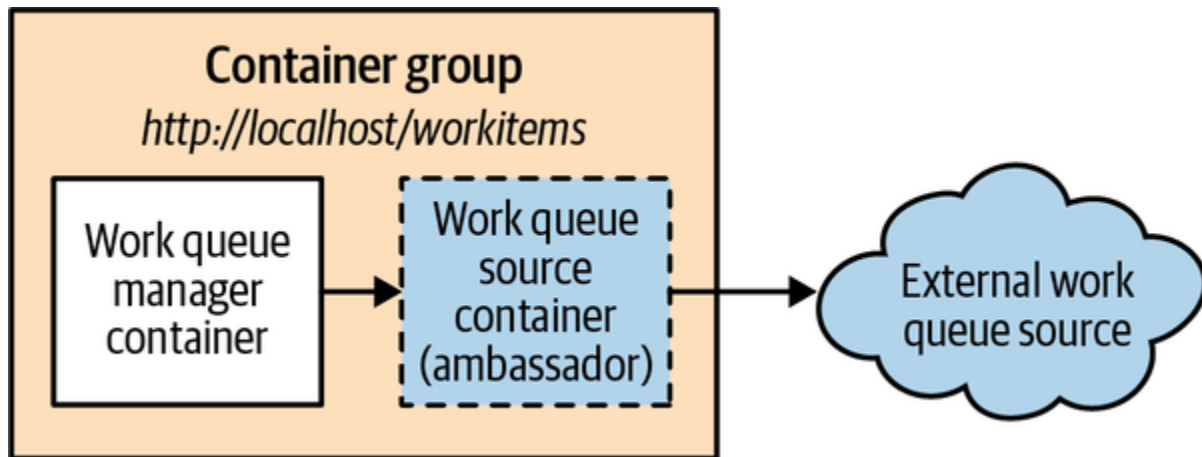

Figure 11-3. The work queue container group

Interestingly, while the ambassador container is clearly application-specific, there is also a variety of generic implementations of the work queue source API. For example, a source might be a list of pictures stored in a cloud storage API, a collection of files stored on network storage, or a queue in a pub/sub system like Kafka or Redis. In these cases, though the user chooses the particular work queue ambassador that fits their scenario, they should be reusing a single generic “library” implementation of the container itself. This minimizes work and maximizes code reuse.

Work Queue API

Given this coordination between the generic work-queue manager and the application-specific ambassador, we need a formal definition of the interface between the two containers. Though there are a variety of different protocols, an HTTP RESTful API is both the easiest to implement as well

as the de facto standard for such an interface. The coordinating work queue expects the ambassador to implement the following URLs:

- GET `http://localhost/api/v1/items`
- GET `http://localhost/api/v1/items/<item-name>`

NOTE

You might wonder why we include a `v1` in the API definition. Will there ever be a `v2` of this interface? It may not seem logical, but it costs very little to version your API when you initially define it. Refactoring versioning onto an API without it, on the other hand, is very expensive. Consequently, it is a best practice to always add versions to your APIs even if you're not sure they will ever change. Better safe than sorry.

The `/items/` URL returns a complete list of all items:

```
{
  kind: ItemList,
  apiVersion: v1,
  items: [
    "item-1",
    "item-2",
    ...
  ]
}
```

The `/items/<item-name>` URL provides the details for a specific item:

```
{
  kind: Item,
  apiVersion: v1,
  data: {
    "some": "json",
    "object": "here",
  }
}
```

Importantly, you will notice that this API doesn't have any affordances for recording that a work item has been processed. We could have designed a more complicated API and then pushed more implementation into the ambassador container, but remember, the goal of this effort is to place as much of the generic implementation inside of the generic work queue manager as possible. To that end, the work queue manager itself is responsible for tracking which items have been processed and which items remain to be processed.

The item details are obtained from this API, and the `item.data` field is passed along to the worker interface for processing.

The Worker Container Interface

Once a particular work item has been obtained by the work queue manager, it needs to be processed by a worker. This is the second container interface

in our generic work queue. This container and interface are slightly different than the previous work queue source interface for a few reasons. The first is that it is a one-off API: a single call is made to begin the work, and no other API calls are made throughout the life of the worker container. Secondly, the worker container is not inside a container group with the work queue manager. Instead, it is launched via a container orchestration API and scheduled to its own container group. This means that the work queue manager has to make a remote call to the worker container in order to start work. It also means that we may need to be more careful about security to prevent a malicious user in our cluster from injecting extra work into the system.

With the work queue source API, we used a simple HTTP-based API for sending items back to the work queue manager. This was because we needed to make repeated calls to the API, and security wasn't a concern since everything was running on localhost. With the worker container, we only need to make a single call, and we want to ensure that other users in the system can't accidentally or maliciously add work to our workers. Consequently, for the worker container, we will use a file-based API. Namely, when the worker container is created, it will receive an environment variable named `WORK_ITEM_FILE`; this will point to a file in the container's local filesystem, where the `data` field from a work item has been written to a file. Concretely, as you will see below, this API can be implemented via a Kubernetes `ConfigMap` object that can be mounted into a container group as a file, as illustrated in [Figure 11-4](#).

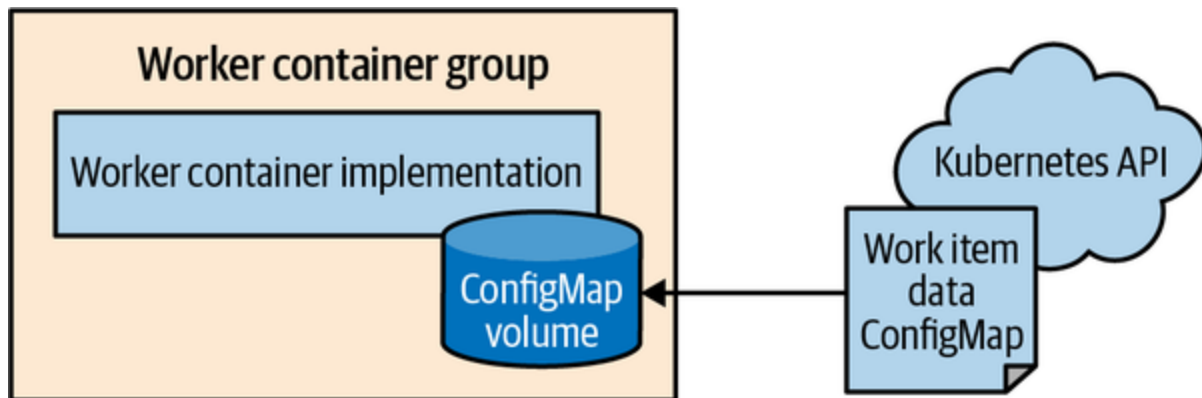

Figure 11-4. The work queue worker API

This file-based API pattern is also easier for the container to implement. Often a work queue worker is simply a shell script across a few command-line tools. In that context, spinning up a web server to manage the work to perform is an unnecessary complexity. As was true with the work queue source implementation, most of the worker containers will be special-purpose container images built for specific work queue applications, but there are also generic workers that can be applied to multiple different work queue applications.

Consider the example of a work queue worker that downloads a file from cloud storage and runs a shell script with that file as input, and then copies its output back up to cloud storage. Such a container can be mostly generic but then have the specific script to execute supplied to it as a runtime parameter. In this way, most of the work of file handling can be shared by multiple users/work queues and only the specifics of file processing need to be supplied by the end user.

The Shared Work Queue Infrastructure

Given implementations of the two container interfaces described previously, what is left to implement our reusable work queue implementation? The basic algorithm for the work queue is fairly straightforward:

1. Load the available work by calling into source container interface.
2. Consult with work queue state to determine which work items have been processed or are being processed currently.
3. For these items, spawn jobs that use the worker container interface to process the work item.
4. When one of these worker containers finishes successfully, record that the work item has been completed.

While this algorithm is simple to express in words, it is somewhat more complicated to implement in reality. Fortunately for us, the Kubernetes container orchestrator contains a number of features that make it significantly easier to implement. Namely, Kubernetes contains a `Job` object that allows for the reliable execution of the work queue. The `Job` can be configured to either run the worker container once or to run it until it completes successfully. If the worker container is set to run to completion, then even if a machine in the cluster fails, the job will eventually be run to success. This dramatically simplifies the task of building a work queue because the orchestrator takes on responsibility for the reliable operation of each work item.

Additionally, Kubernetes has annotations for each `Job` object that enable us to mark each job with the work item it is processing. This enables us to understand which items are being processed as well as those that have completed in either failure or success.

Put together, this means that we can implement a work queue on top of the Kubernetes orchestration layer without using any storage of our own.

Thus, the expanded operation of our work queue container looks like this:

```
Repeat forever
  Get the list of work items from the work source
  Get the list of all jobs that have been created in the
  queue.
  Difference these lists to find the set of work items that
  have not been processed.
  For these unprocessed items, create new Job objects and
  launch appropriate worker containers.
```

Here is a simple Python script that implements this work queue:

```
import requests
import json
from kubernetes import client, config
import time
```

```
namespace = "default"

def make_container(item, obj):
    container = client.V1Container()
    container.image = "my/worker-image"
    container.name = "worker"
    return container

def make_job(item):
    response = requests.get("http://localhost:8000")
    obj = json.loads(response.text)
    job = client.V1Job()
    job.metadata = client.V1ObjectMeta()
    job.metadata.name = item
    job.spec = client.V1JobSpec()
    job.spec.template = client.V1PodTemplate()
    job.spec.template.spec = client.V1PodTemplateSpec()
    job.spec.template.spec.restart_policy = "Never"
    job.spec.template.spec.containers = [
        make_container(item, obj)
    ]
    return job

def update_queue(batch):
    response = requests.get("http://localhost:8000")

    obj = json.loads(response.text)
    items = obj['items']
```

```
ret = batch.list_namespaced_job(namespace, wa

for item in items:
    found = False
    for i in ret.items:
        if i.metadata.name == item:
            found = True
    if not found:
        # This function creates the job object
        # brevity
        job = make_job(item)
        batch.create_namespaced_job(namespace

config.load_kube_config()
batch = client.BatchV1Api()

while True:
    update_queue(batch)
    time.sleep(10)
```

Hands On: Implementing a Video Thumbnailer

To provide a concrete example of how we might use a work queue, consider the task of generating thumbnails for videos. These thumbnails help users determine which videos they want to watch.

To implement this video thumbnailer, we need two different user containers. The first is the work item source container. The simplest way for this to work is for the work items to appear on a shared disk, such as a Network File System (NFS) share. The work item source simply lists the files in this directory and returns them to the caller. Here's a simple `node` program that does this:

```
const http = require('http');
const fs = require('fs');

const port = 8080;
const path = process.env.MEDIA_PATH;

const requestHandler = (request, response) => {
  console.log(request.url);
  fs.readdir(path + '/*.mp4', (err, items) {
    var msg = {
      'kind': 'ItemList',
      'apiVersion': 'v1',
      'items': []
    };
    if (!items) {
      return msg;
    }
  });
};
```

```
        }
        for (var i = 0; i < items.length; i++) {
            msg.items.push(items[i]);
        }
        response.end(JSON.stringify(msg));
    });
}

const server = http.createServer(requestHandler);

server.listen(port, (err) => {
    if (err) {
        return console.log('Error starting server');
    }

    console.log(`server is active on ${port}`);
});
```

This source of defines the queue of movies to thumbnail. We use the `ffmpeg` utility to actually perform the thumbnailing work.

You can create a container that uses the following as its command line:

```
ffmpeg -i ${INPUT_FILE} -frames:v 100 thumb.png
```

This command will take one frame every 100 frames (that's the `-frames:v 100` flag) and output it as a PNG file (e.g., `thumb1.png`, `thumb2.png`, etc.).

You can create the `ffmpeg` container using a base image of your choice and installing the `ffmpeg` executable in that container. There is also an open source project with Dockerfiles for many popular operating systems [on GitHub](#). You can use those scripts as a starting point for your container image.

By defining a simple source container as well as an even simpler worker container, we can clearly see the power and utility of a generic container-based queuing system. It dramatically reduces the time/distance between an idea for implementing a work queue and the corresponding concrete implementation.

Dynamic Scaling of the Workers

The previously described work queue is great for processing work items as quickly as they arrive in the work queue, but this can lead to bursty resource loads being placed onto a container orchestrator cluster. This is good if you have a lot of different workloads that will burst at different times and thus keep your infrastructure evenly utilized. But if you don't have a sufficient number of different workloads, this feast or famine approach to scaling your

work queue might require that you over-provision resources to support the bursts that will lie idle (and cost too much money) while you don't have work to perform.

To address this problem, you can limit the overall number of `Job` objects that your work queue is willing to create. This will naturally serve to limit the number of work items you process in parallel and consequentially limit the maximum amount of resources that you use at a particular time.

However, doing this will increase the time to completion (latency) for each work item being completed when under heavy load. If the load is bursty, then this is probably OK because you can use the slack times to catch up with the backlog that developed during a burst of usage. However, if your steady-state usage is too high, your work queue may never be able to catch up, and the time to completion will simply get longer and longer.

When your work queue is faced with this situation, you need to have it dynamically adjust itself to increase the parallelism that it is willing to create (and correspondingly the resources it is willing to use) so that it can keep up with the incoming work. Fortunately, there are mathematical formulas that we can use to determine when we need to dynamically scale up our work queue.

Consider a work queue where a new work item arrives an average of once every minute, and each work item takes an average of 30 seconds to complete. Such a system is capable of keeping up with all of the work it

receives. Even if a large batch of work arrives all at once and creates a backlog, on average the work queue processes two work items for every one work item that arrives, and thus it will be able to gradually work through its backlog.

If, instead, a new work item arrives on average once every minute and it takes an average of one minute to process each work item, then the system is perfectly balanced, but it does not handle variance well. It can catch up with bursts—but it will take a while, and it has no slack or capacity to absorb a sustained increase in the rate at which new work items arrive. This is probably not an ideal way to run, as some safety margin for growth and other sustained increases in work (or unexpected slowdowns in processing) is needed to preserve a stable system.

Finally, consider a system in which a work item arrives every minute and each item takes two minutes to process. In such a system, we are always losing ground. The queue of work will grow without bound, and the latency of any one item in the queue will grow toward infinity (and our users will become very frustrated).

Thus, we can keep track of both of these metrics for our work queue, and the average time between work items over an extended period of time ($\#$ work items / 24 hours) will give us the *interarrival time* for new work. We can also keep track of the average *latency*, the time to process any one item once we start working on it, not counting any time spent waiting in the

queue. To have a stable work queue, we need to adjust the number of resources so that latency is less than the interarrival time of new items. If we are processing work items in parallel, we also divide the processing time for a work item by the parallelism. For example, if each item takes one minute to process but we process four items in parallel, the effective time to process one item is 15 seconds, and thus we can sustain an interarrival period of 16 or more seconds.

This approach makes it fairly straightforward to build an autoscaler to dynamically size up our work queue. Sizing down the work queue is somewhat trickier, but you can use the same math as well as a heuristic for the amount of spare capacity for the safety margin you want to maintain. For example, you can reduce the parallelism until the processing time for an item is 90% of the interarrival time for new items. While in some cases it is more efficient to build your own scaler, many times it is better to use an open source solution. That is where the [Kubernetes Event-Driven Autoscaling \(KEDA\) project](#) is useful. KEDA provides numerous different event-based scalers, which can be used to scale your application. KEDA supports event sources ranging from files on disk to events in pub/sub systems and many more.

The Multiworker Pattern

One of the themes of this book has been the use of containers for encapsulation and reuse of code. The same holds true for the work queue patterns described in this chapter. In addition to the patterns for reusing containers for driving the work queue itself, you can also reuse multiple different containers to compose a worker implementation. Suppose, for example, that you have three different types of work that you want to perform on a particular work queue item. For example, you might want to detect faces in an image, tag those faces with identities, and then blur the faces in the image. You could write a single worker to perform this complete set of tasks, but this would be a bespoke solution that would not be reusable the next time you want to identify something else, such as cars, yet still provide the same blurring.

To achieve this kind of code reuse, the *multiworker pattern* is something of a specialization of the adapter pattern described in previous chapters. In this case, the multiworker pattern transforms a collection of different worker containers into a single unified container that implements the worker interface, yet delegates the actual work to a collection of different reusable containers. This process is illustrated in [Figure 11-5](#).

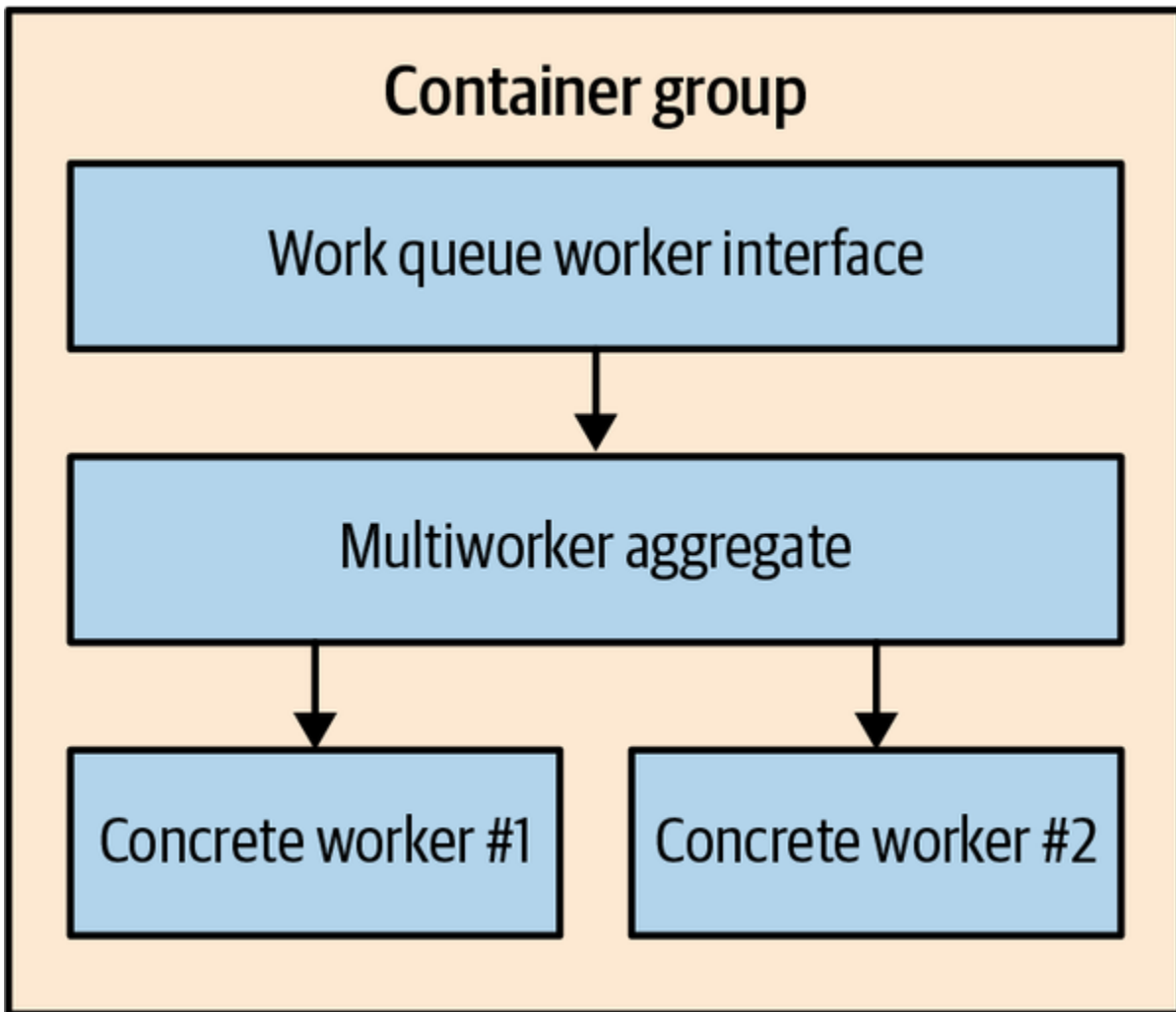

Figure 11-5. The multiworker aggregator pattern as a group of containers

Because of this code reuse, the composition of multiple different worker containers means an increase in the reuse of code and a reduction in effort for people designing batch-oriented distributed systems.

Summary

This chapter begins the discussion of batch systems by introducing *workflows*. A workflow is a sequence of discrete actions which, when put together in a sequence, achieve some goal like the processing of an order or the machine-learning analysis of a video. This chapter showed how containers can be used to build modular workflows with sidecar containers providing workflow orchestration while application containers supply the specific processing necessary for your workflow. Workflow is a key part of most distributed batch systems. Its generic pattern is easy to adapt and extend to meet the specific needs of your workload.

Chapter 12. Event-Driven Batch Processing

In [Chapter 11](#), we saw a generic framework for work queue processing, as well as a number of example applications of simple work queue processing. Work queues are great for enabling individual transformations of one input to one output. However, there are a number of batch applications where you want to perform more than a single action, or you may need to generate multiple different outputs from a single data input. In these cases, you start to link work queues together so that the output of one work queue becomes the input to one or more other work queues, and so on. This forms a series of processing steps that respond to events, with the events being the completion of the preceding step in the work queue that came before it.

These sort of event-driven processing systems are often called *workflow* systems, since there is a flow of work through a directed, acyclic graph that describes the various stages and their coordination. A basic illustration of such a system is shown in [Figure 12-1](#).

The most straightforward application of this type of system simply chains the output of one queue to the input of the next queue. But as systems become more complicated, there are a series of different patterns that emerge for linking a series of work queues together. Understanding and designing in terms of these patterns is important for comprehending how

the system is working. The operation of an event-driven batch processor is similar to event-driven FaaS. Consequently, without an overall blueprint for how the different event queues relate to each other, it can be hard to fully understand how the system is operating. Furthermore, though the initial design of a work queue can be straightforward, correctly handling errors and other unexpected conditions rapidly makes a simple work queue much more complicated.

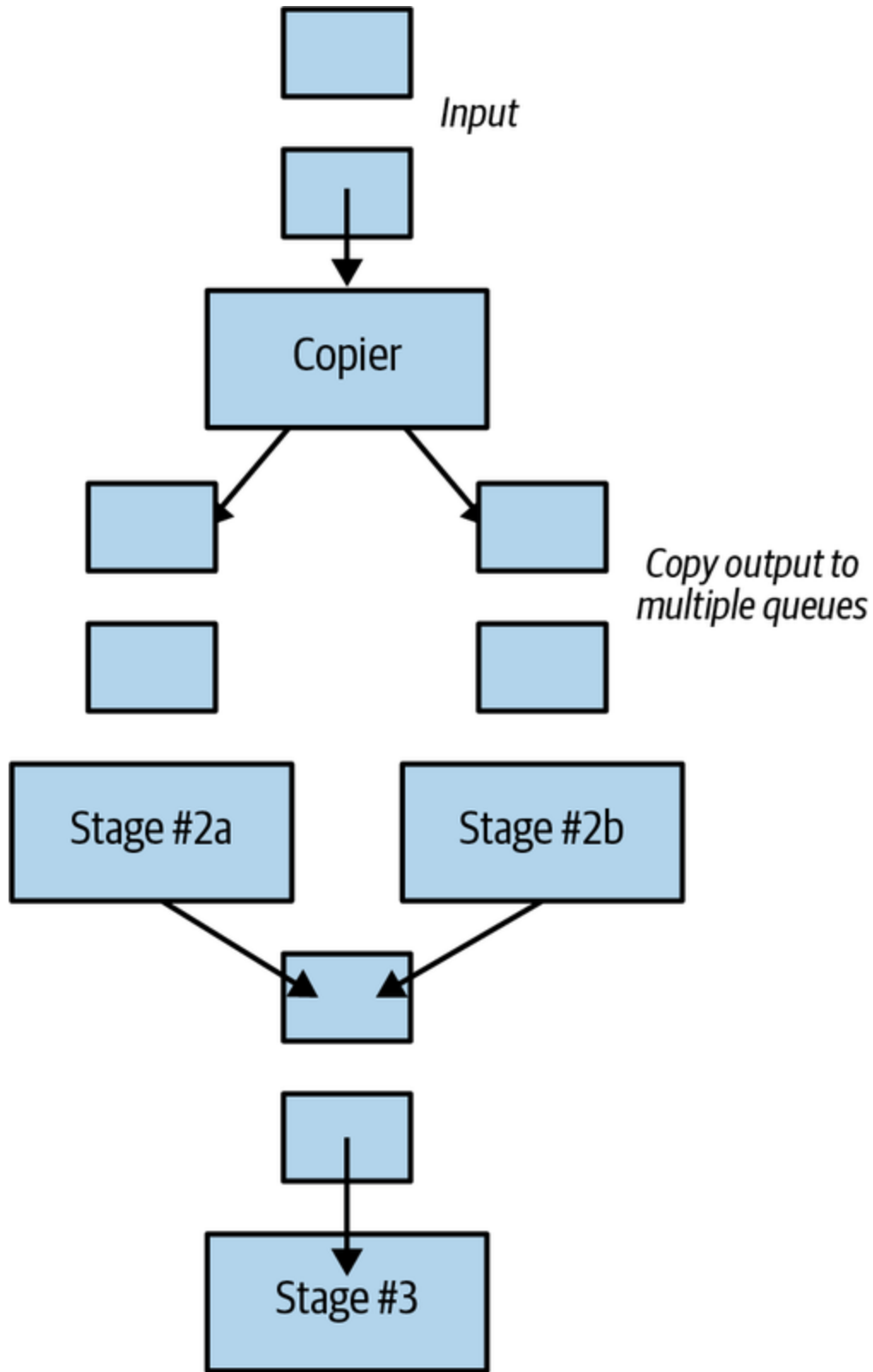

Figure 12-1. This workflow combines copying work into multiple queues (Stage 2a, 2b), parallel processing of those queues, and combining the result back into a single queue (Stage 3)

Patterns of Event-Driven Processing

Beyond the simple work queue described in [Chapter 11](#), there are a number of patterns for linking work queues together. The simplest pattern—one where the output of a single queue becomes the input to a second queue—is straightforward enough that we won't cover it here. We will describe patterns that involve the coordination of multiple different queues or the modification of the output of one or more work queues.

Copier

The first pattern for coordinating work queues is a copier. The job of a copier is to take a single stream of work items and duplicate it out into two or more identical streams. This pattern is useful when there are multiple different pieces of work to be done on the same work item. An example of this might be rendering a video. When rendering a video, there are a variety of different formats that are useful, depending on where the video is intended to be shown. There might be a 4K high-resolution format for playing off of a hard drive, a 1080-pixel rendering for digital streaming, a low-resolution format for streaming to mobile users on slow networks, and an animated GIF thumbnail for displaying in a movie-picking user interface. All of these work items can be modeled as separate work queues for each render, but the input to each work item is identical. An illustration of the copier pattern applied to transcoding is shown in [Figure 12-2](#).

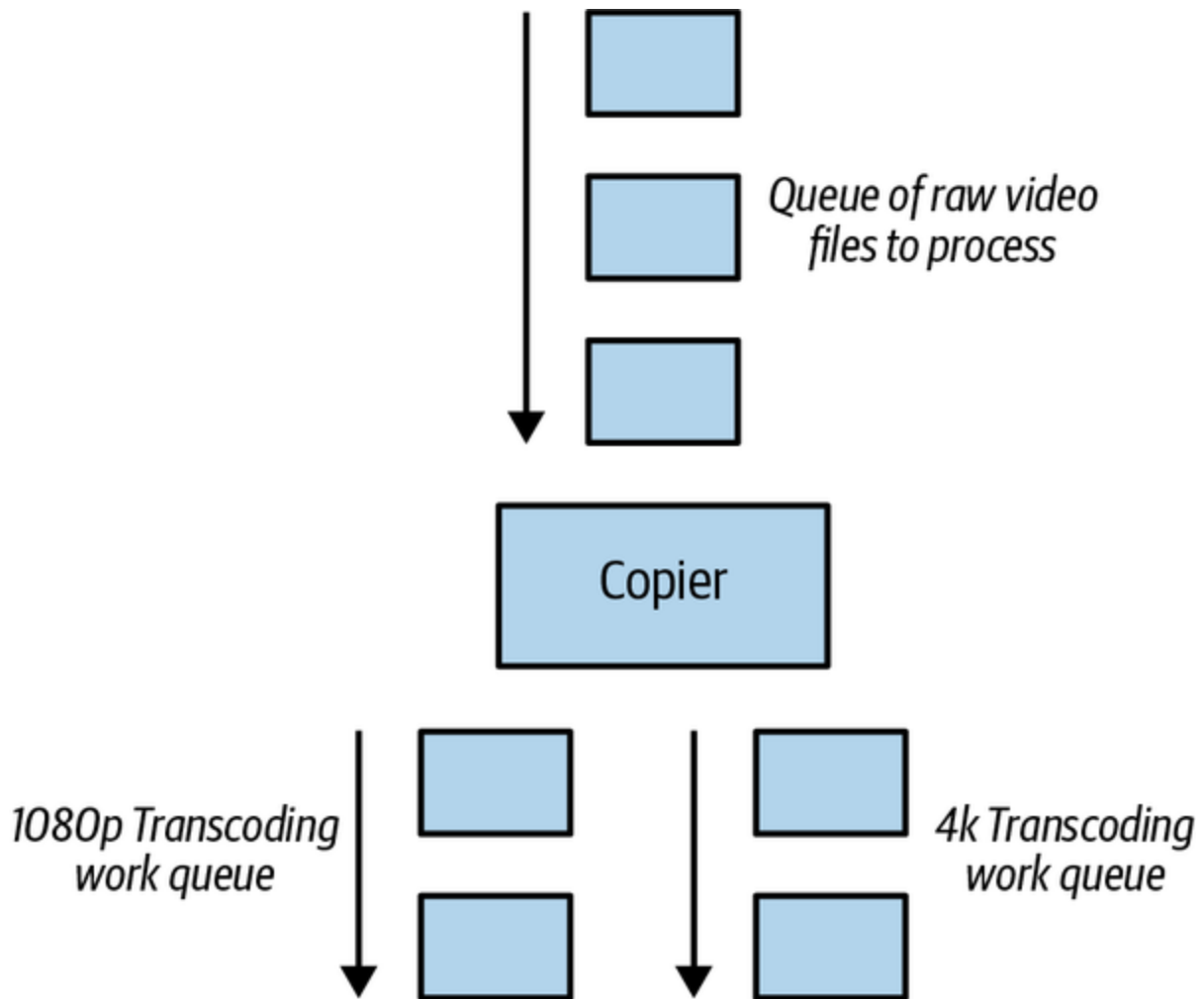

Figure 12-2. The copier batch pattern for transcoding

The copy pattern can also be used to trade additional computational power for increased reliability or performance. Imagine that you have a worker processing work that usually takes one second to run, but occasionally takes one minute (60x slowdown). If you process every work item twice and take whichever result completes first, you are much less likely to be impacted by this slowdown. Similarly, if your worker crashes 1% of the time, you can go from a two-nines (99% reliable) system to a four-nines (99.99% reliable) simply by processing every item twice. Obviously, in both cases, doing the

engineering work to improve the system is a better long-term solution. But sometimes as a temporary workaround, or in situations where the engineering work isn't possible, it's useful to be able to just throw resources at the problem.

Filter

The second pattern for event-driven batch processing is a filter. The role of a filter is to reduce a stream of work items to a smaller stream of work items by filtering out work items that don't meet particular criteria. As an example of this, consider setting up a batch workflow that handles new users signing up for a service. Some set of those users will have ticked the checkbox that indicates that they wish to be contacted via email for promotions and other information. In such a workflow, you can filter the set of newly signed-up users to only be those who have explicitly opted into being contacted.

Ideally you would compose a filter work queue source as an ambassador that wraps up an existing work queue source. The original source container provides the complete list of items to be worked on, and the filter container then adjusts that list based on the filter criteria and only returns those filtered results to the work queue infrastructure. An illustration of this use of the adapter pattern is shown in [Figure 12-3](#).

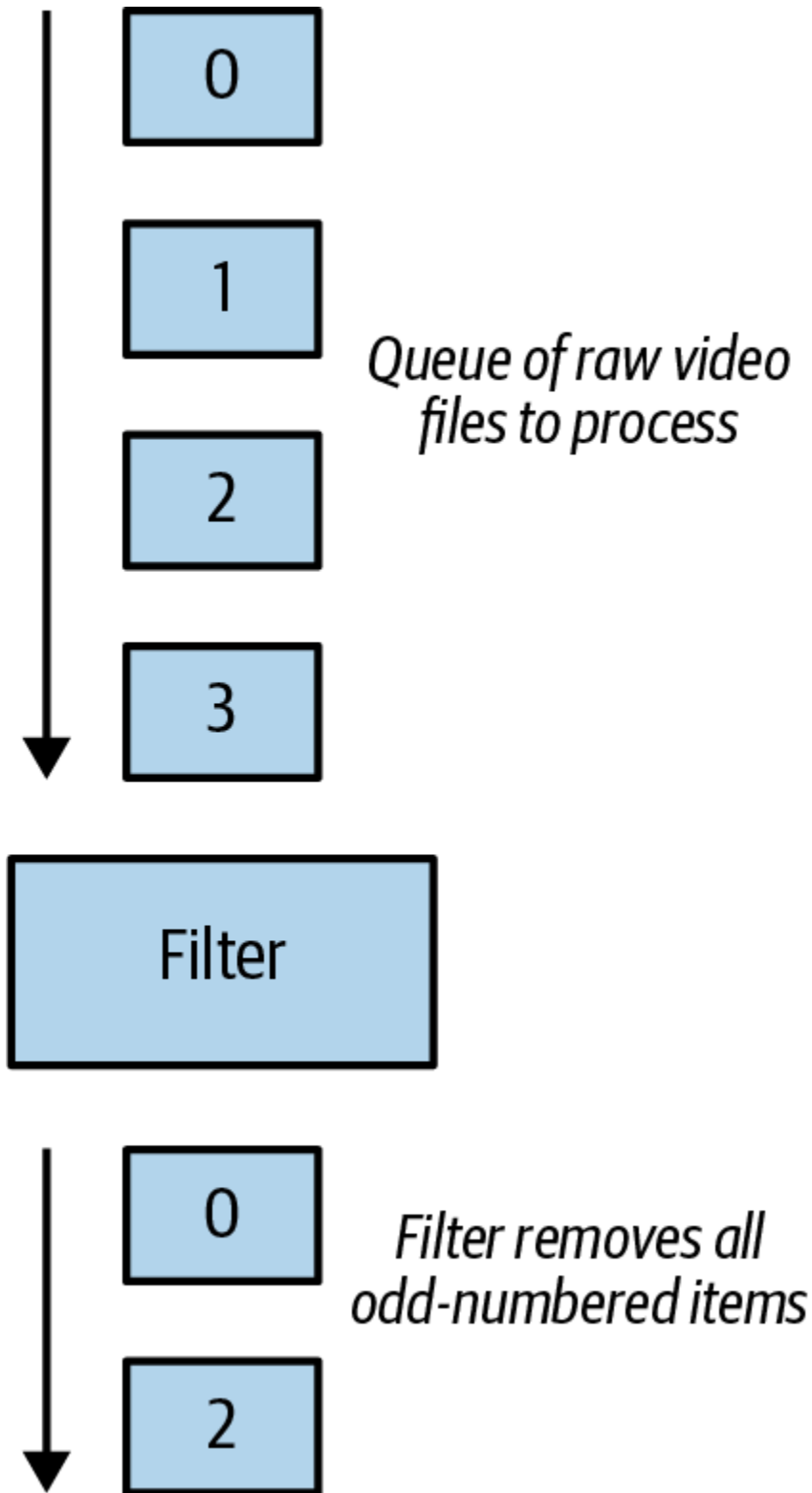

Figure 12-3. An example of a filter pattern that removes all odd-numbered work items

Splitter

Sometimes you don't want to just filter things out by dropping them on the floor, but rather you have two different kinds of input present in your set of work items, and you want to divide them into two separate work queues without dropping any of them. For this task, you want to use a splitter. The role of a splitter is to evaluate some criteria—just like a filter—but instead of eliminating input, the splitter sends different inputs to different queues based on that criteria.

An example of an application of the splitter pattern is processing online orders where people can receive shipping notifications either by email or text message. Given a work queue of items that have been shipped, the splitter divides it into two different queues: one that is responsible for sending emails and another devoted to sending text messages. A splitter can also be a copier if it sends the same output to multiple queues, such as when a user selects both text messages and email notifications in the previous example. It is interesting to note that a splitter can actually also be implemented by a copier and two different filters. But the splitter pattern is a more compact representation that captures the job of the splitter more succinctly. This is a little like the fact that an XOR (exclusive or) logic gate can actually be implemented with OR/NOT/AND gates, but it is convenient to think of it as an XOR. An example of using the splitter pattern to send shipping notifications to users is shown in [Figure 12-4](#).

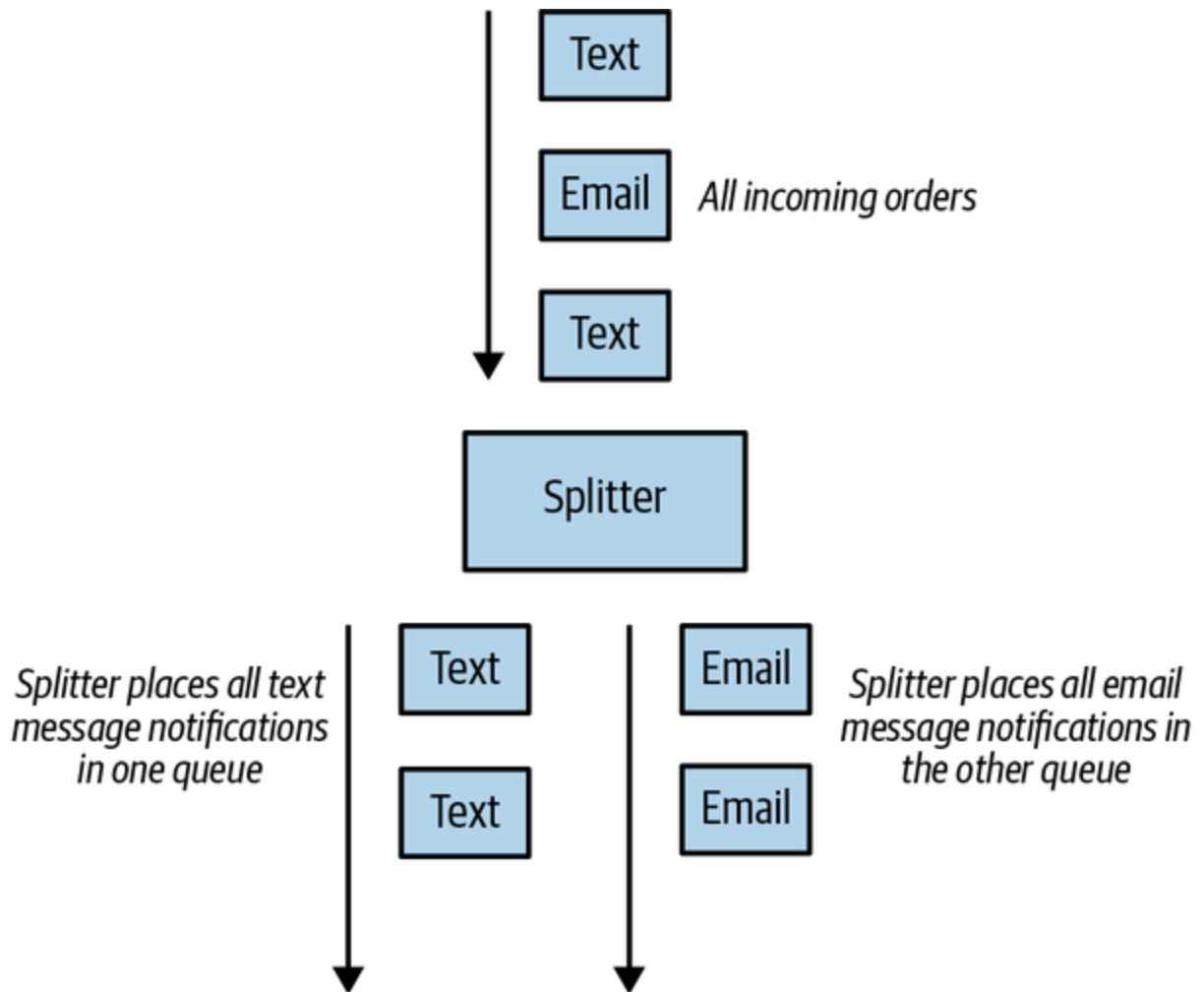

Figure 12-4. An example of the batch splitter pattern splitting shipping notifications into two different queues

Sharder

A slightly more generic form of splitter is a sharder. Much like the sharded server that we saw in earlier chapters, the role of a sharder in a workflow is to divide up a single queue into an evenly divided collection of work items based upon some sort of *sharding function*. There are several different reasons why you might consider sharding your workflow. One of the first is for reliability. If you shard your work queue, then the failure of a single

workflow due to a bad update, infrastructure failure, or other problem only affects a fraction of your service.

For example, imagine that you push a bad update to your worker container, which causes your workers to crash and your queue to stop processing work items. If you only have a single work queue that is processing items, then you will have a complete outage for your service with all users affected. If, instead, you have sharded your work queue into four different shards, you have the opportunity to do a staged rollout of your new worker container. Assuming you catch the failure in the first phase of the staged rollout, sharding your queue into four different shards means that only one-quarter of your users would be affected.

An additional reason to shard your work queue is to more evenly distribute work across different resources. If you don't really care which region or data center is used to process a particular set of work items, you can use a sharder to evenly spread work across multiple data centers to even out utilization of all data centers/regions. As with updates, spreading your work queue across multiple failure regions also has the benefit of providing reliability against data center or region failures. An illustration of a sharded queue when everything is working correctly is shown in [Figure 12-5](#).

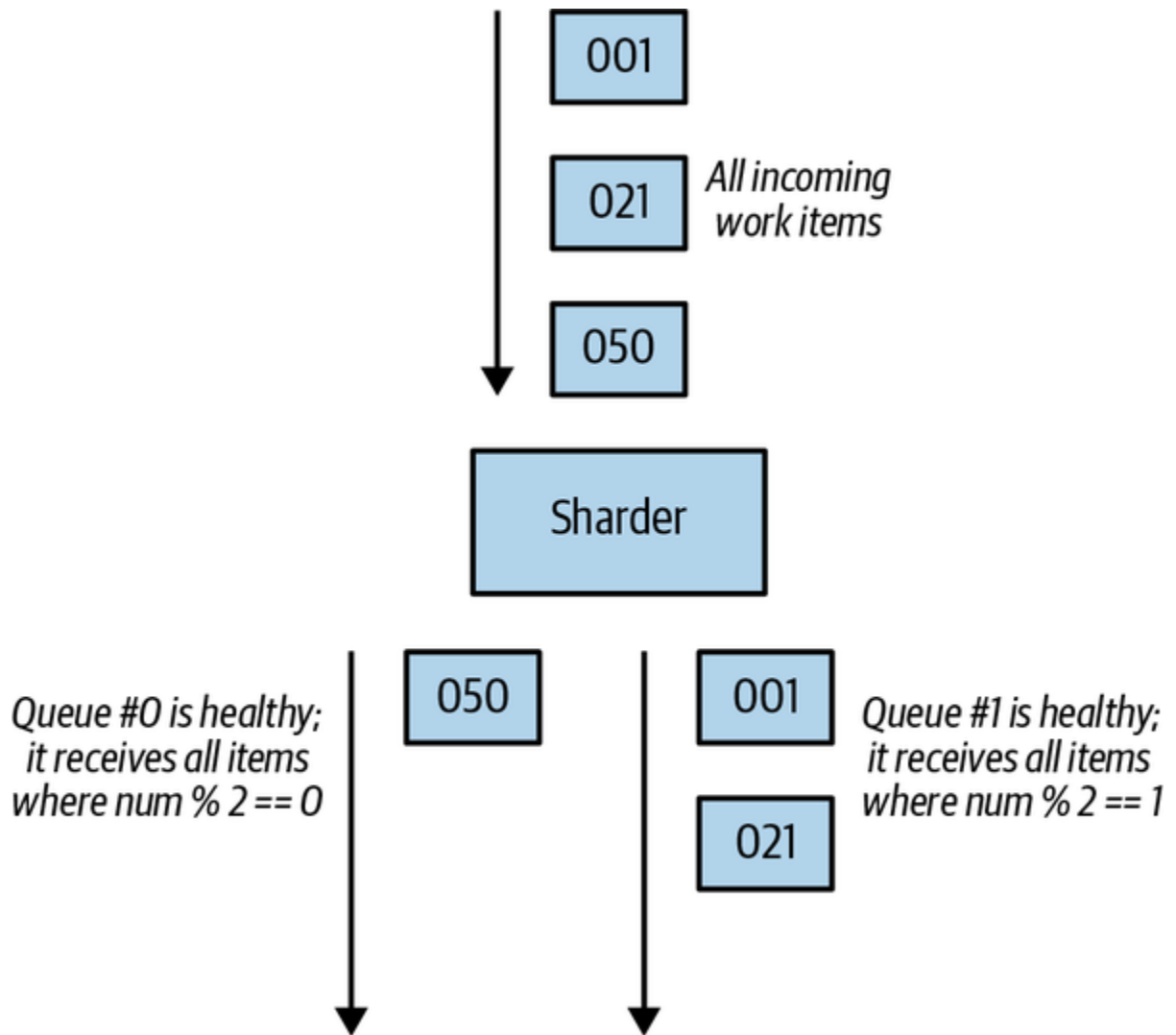

Figure 12-5. An example of the sharding pattern in a healthy operation

When the number of healthy shards is reduced due to failures, the sharding algorithm dynamically adjusts to send work to the remaining healthy work queues, even if only a single queue remains.

This is illustrated in [Figure 12-6](#).

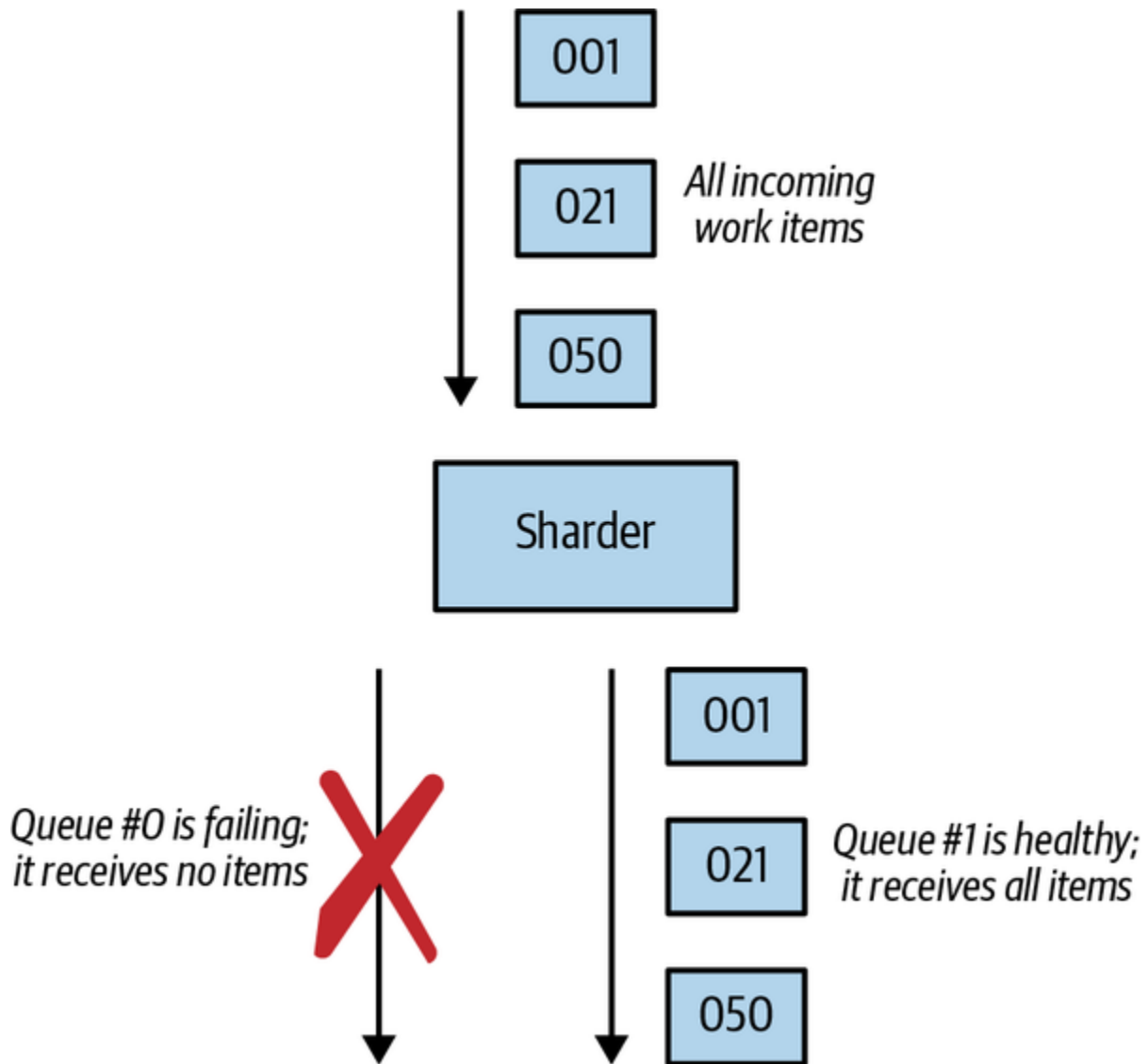

Figure 12-6. When one work queue is unhealthy, the remaining work spills over to a different queue

Merger

The last pattern for event-driven or workflow batch systems is a *merger*. A merger is the opposite of a copier; the job of a merger is to take two different work queues and turn them into a single work queue. Suppose, for example, that you have a large number of different source repositories all

adding new commits at the same time. You want to take each of these commits and perform a build-and-test for it. It is not scalable to create a separate build infrastructure for each source repository. We can model each of the different source repositories as a separate work queue source that provides a set of commits. We can transform all of these different work queue inputs into a single merged set of inputs using a merger adapter. This merged stream of commits is then the single source to the build system that performs the actual build. The merger is another great example of the adapter pattern, though in this case, the adapter is actually adapting multiple running source containers into a single merged source.

This multiadapter pattern is shown in [Figure 12-7](#).

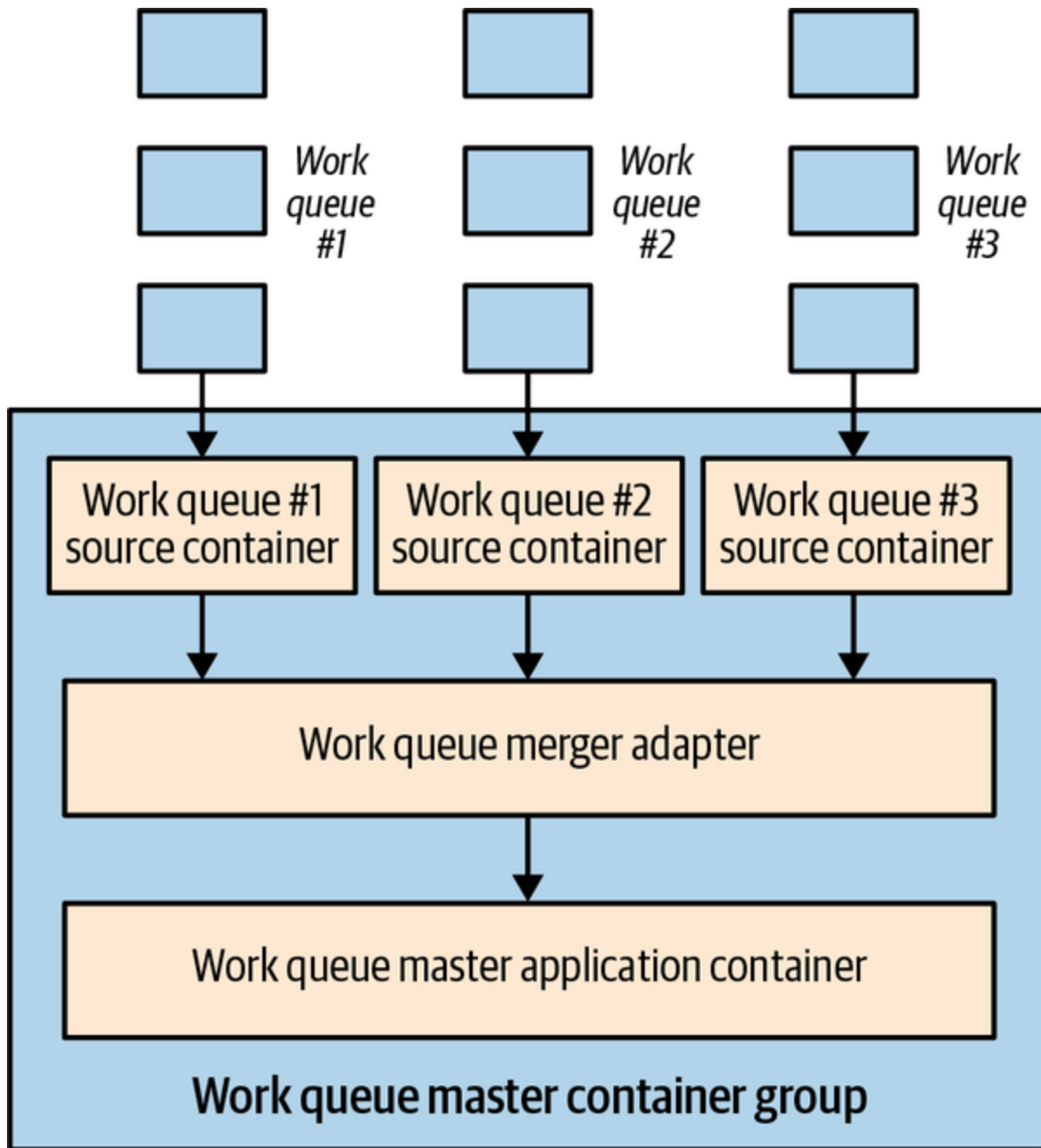

Figure 12-7. Using multiple levels of containers to adapt multiple independent work queues into a single shared queue

Hands On: Building an Event-Driven Flow for New User Signup

A concrete example of a workflow helps show how these patterns can be put together to form a complete operating system. The problem this example will consider is a new user signup flow.

Imagine that our user acquisition funnel has two stages. The first is user verification. After a new user signs up, the user then has to receive an email notification to validate their email. Once the user validates their email, they are sent a confirmation email. Then they are optionally registered for email, text message, both, or neither for notifications.

The first step in the event-driven workflow is the generation of the verification email. To achieve this reliably, we will use the shard pattern to shard users across multiple different geographic failure zones. This ensures that we will continue to process new user signups, even in the presence of partial failures. Each work queue shard sends a verification email to the end user. At this point, this substage of the workflow is complete. This first stage of the flow is illustrated in [Figure 12-8](#).

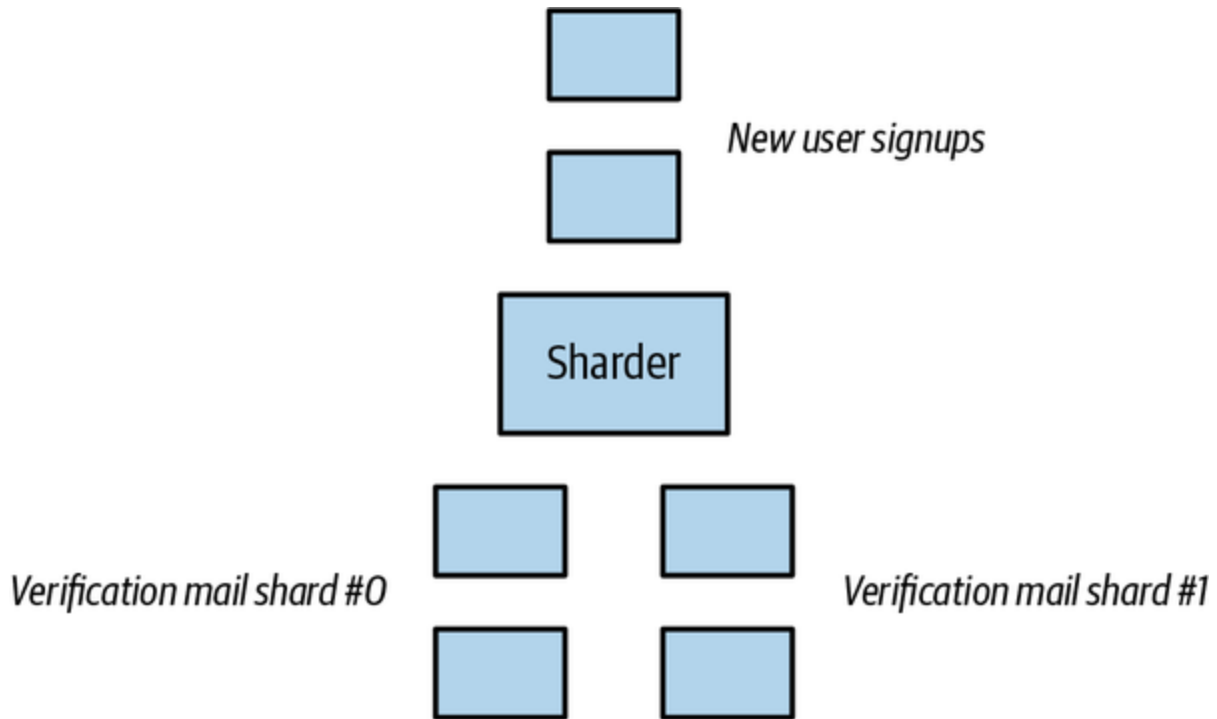

Figure 12-8. The first stage of the workflow for user signup

The workflow begins again when we receive a verification email from the end user. These emails become new events in a separate (but clearly related) workflow that sends welcome emails and sets up notifications. The first stage of this workflow is an example of the copier pattern, where the user is copied into two work queues. The first work queue is responsible for sending the welcome email, and the second work queue is responsible for setting up user notifications.

Once the work items have been duplicated between the queues, the email-sending queue simply takes care of sending an email message, and the workflow exits. But remember that because of the use of the copier pattern, there is still an additional copy of the event active in our workflow. This

copier triggers an additional work queue to handle notification settings. This work queue feeds into an example of the filter pattern, which splits the work queue into separate email and text message notification queues. These specific queues register the user for email, text, or both notifications.

The remainder of this workflow is shown in [Figure 12-9](#).

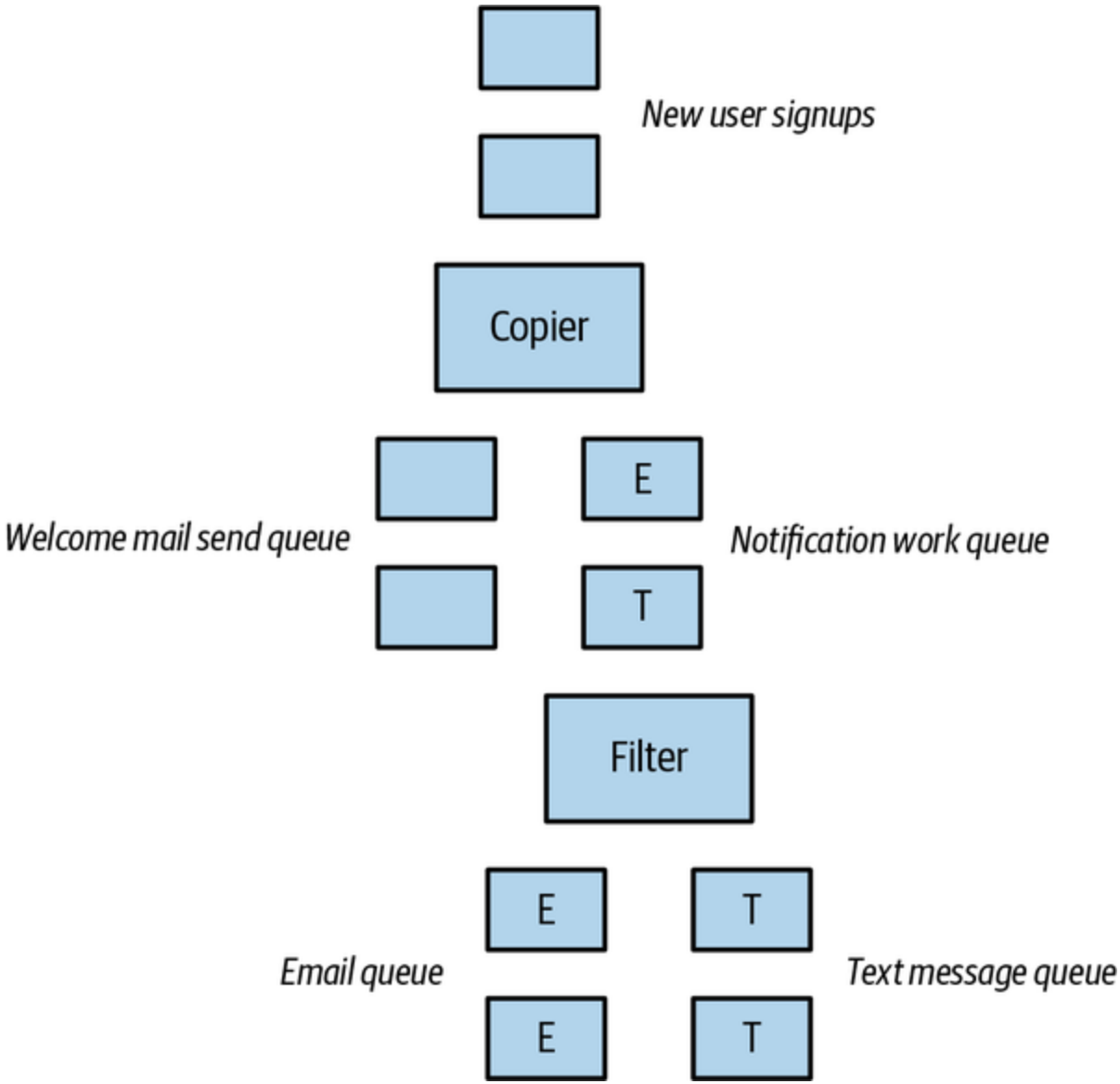

Figure 12-9. The user notification and welcome email work queue

Publisher/Subscriber Infrastructure

We have seen a variety of abstract patterns for linking together different event-driven batch processing patterns. But when it comes time to actually build such a system, we need to figure out how to manage the stream of data that passes through the event-driven workflow. The simplest thing to do would be to simply write each element in the work queue to a particular directory on a local filesystem, and then have each stage monitor that directory for input. But of course doing this with a local filesystem limits our workflow to operating on a single node. We can introduce a network filesystem to distribute files to multiple nodes, but this introduces increasing complexity both in our code and in the deployment of the batch workflow.

Instead, a popular approach to building a workflow like this is to use a publisher/subscriber (pub/sub) API or service. A pub/sub API allows a user to define a collection of queues (sometimes called topics). One or more *publishers* publishes messages to these queues. Likewise, one or more *subscribers* is listening to these queues for new messages. When a message is published, it is reliably stored by the queue and subsequently delivered to subscribers in a reliable manner.

At this point, most public clouds feature a pub/sub API such as Azure's EventGrid or Amazon's Simple Queue Service. Additionally, the open

source [Kafka project](#) provides a very popular pub/sub implementation that you can run on your own hardware as well as on cloud virtual machines. For the remainder of this overview of pub/sub APIs, we'll use Kafka for our examples, but they are relatively simple to port to alternate pub/sub APIs.

Hands On: Deploying Kafka

There are obviously many ways to deploy Kafka, and one of the easiest ways is to run it as a container using a Kubernetes cluster and the Helm package manager.

Helm is a package manager for Kubernetes that makes it easy to deploy and manage prepackaged off-the-shelf applications like Kafka. If you don't already have the `helm` command-line tool installed, [you can install it from the Helm website](#).

Once the `helm` tool is on your machine, you need to initialize it. Initializing Helm deploys a cluster-side component named `tiller` to your cluster and installs some templates to your local filesystem:

```
helm init
```

Now that Helm is initialized, you can install Kafka using this command:

```
helm repo add incubator http://storage.googleapis.com/kube-incubator
```

```
helm install --name kafka-service incubator/kafka
```

NOTE

Helm templates have different levels of production hardening and support. `stable` templates are the most strictly vetted and supported, whereas `incubator` templates like Kafka are more experimental and have less production mileage. Regardless, incubator templates are useful for quick proof of concepts as well as a place to start from when implementing a production deployment of a Kubernetes-based service.

Once you have Kafka up and running, you can create a topic to publish to. Generally in batch processing, you're going to use a topic to represent the output of one module in your workflow. This output is likely to be the input for another module in the workflow.

For example, if you are using the `Sharder` pattern described previously, you would have a topic for each of the output shards. If you called your output `PHOTOS` and you chose to have three shards, then you would have three topics: `PHOTOS-1`, `PHOTOS-2`, and `PHOTOS-3`. Your sharder module would output messages to the appropriate topic after applying the sharding function.

Here's how you create a topic. First, create a container in the cluster so that you can access Kafka:

```
for x in 0 1 2; do
```

```
kubectl run kafka --image=solsson/kafka:0.11.0
  ./bin/kafka-topics.sh --create --zookeeper ka
  --replication-factor 3 --partitions 10 --to
done
```

Note that there are two interesting parameters in addition to the topic name and the ZooKeeper service. They are `--replication-factor` and `--partitions`. The replication factor is how many different machines messages in the topic will be replicated to. This is the redundancy that is available in case things crash. A value of 3 or 5 is recommended. The second parameter is the number of partitions for the topic. The number of partitions represents the maximum distribution of the topic onto multiple machines for purposes of load balancing. In this case, since there are 10 partitions, there can be at most 10 different replicas of the topic for load balancing.

Now that we have created a topic, we can send messages to that topic:

```
kubectl run kafka-producer --image=solsson/kafka
  ./bin/kafka-console-producer.sh --broker-list
  --topic photos-1
```

Once that command is up and connected, you should see the Kafka prompt, and you can then send messages to the topic(s). To receive messages, you

can run:

```
kubectl run kafka-consumer --image=solsson/kafka
  ./bin/kafka-console-consumer.sh --bootstrap-s
  --topic photos-1 \
  --from-beginning
```

Of course, running these command lines only gives you a taste of how to communicate via Kafka messages. To build a real-world event-driven batch processing system, you would likely use a proper programming language and Kafka SDK to access the service. But on the other hand, never underestimate the power of a good bash script!

This section has shown how installing Kafka into your Kubernetes cluster can dramatically simplify the task of building a work queue-based system.

Resiliency and Performance in Work Queues

So far in this chapter, we have designed workflows to optimize the design of the work queue to match the problem being addressed by the work queue. This is an important part of engineering. The clearer the design of

the system matches the task, the easier it is to understand, update, and extend. However, an additional critical part of engineering is anticipating and designing systems for both the performance and reliability requirements of the users.

So far, in all of the designs we have assumed that all of the work in the system is roughly identical and each piece of work is equally reliable. Unfortunately, in the real world, neither one of these assumptions is typically true. Unless your system is very, very unusual, it contains a mix of different work. Different videos, different emails, different builds—work queues are constantly dealing with similar but different individual pieces of work.

Work Stealing

The net result of this is that some pieces of work take longer than other pieces of work. Sometimes this is inherent (that movie is just larger), but often it is because of design decisions in our code which are better or worse fits for a specific work item. We may have optimized our code for lots of files and few directories, and the work item might be the opposite: deep directory trees with relatively few files. Oftentimes the latency of individual work items might not matter; if they generally land on different queues via something like sharding, the overall average times generally work out. But unfortunately, sometimes this average performance doesn't work out, and all of the slow items end up on one queue. When this happens, the inputs to

the queue pile up and latency increases, much like a slow checkout lane in a grocery store. Just like in the grocery store, the best option is to move from the slow lane to a lane with a shorter line. This algorithm is called “work stealing.”

The basic algorithm for work stealing says that for any worker, as long as that worker has work on their queue, the work on the queue is performed as you would expect. When there is no work on a worker’s queue, instead of sleeping until more work arrives, the worker takes work off of the back of the longest queue of any other worker. In this way, the maximum length of any work queue is kept to a minimum since workers with shorter work queues remove work from workers with longer queues. Work is taken from the back of the queue because that removal can be done safely without worrying about whether the work may be performed by multiple workers.

Errors, Priority, and Retry

The other problems that can occur in a work queue system come when there are errors processing the work itself. The first problem that can happen is if your worker crashes in the middle of processing the work. In the worst case, the work that was being removed from the queue is lost. Fortunately, most queue systems have semantics where the message being processed is initially removed from the queue for processing. This initial removal hides the message from other workers, but it doesn’t actually remove it from the queue. When the work has been processed, a second “completed” message

is sent to the queue, which permanently removes the work from the queue. Typically a message queue has a timeout after which, if the work has not been “completed,” the work item is returned to the head of the queue for other workers to pick it up.

Unfortunately, recovering from this error results in an additional complication. What if the first worker is merely running slowly, not crashed? Now we have two workers processing the same work item. The easiest way to deal with this situation is to make each work item idempotent. That way the additional processing is wasted computation, but it does not cause any additional errors. If it isn't possible to make your work idempotent, there are various distributed locking methods discussed in previous chapters that can be used. The important takeaway is that when writing a worker, you must assume that multiple workers could be operating on the same work item.

Assuming idempotent work, we're now safe from workers crashing, right? Sadly, it's not that easy. Imagine if the crashing worker is not due to random bugs in the worker's code, but something about the work item itself. Suppose there is a “poison” work item which crashes a worker 100% of the time. In such a situation, where one worker is recovering from the crash, the poison work is picked up by another worker, which itself crashes, causing another worker to pick up the poison and so on and so forth until all of your workers are crashing. Even if you are lucky and your workers recover

quickly, poison work can cause you to lose a significant percentage of your worker capacity and slow down your work queue significantly.

Much as with error handling, the first solution to poison work is to keep track of the number of times that a particular piece of work has been removed from the message queue. We can then use exponential backoff to increase the timeout for the poison message larger and larger until we remove it from processing entirely. Generally, exponential backoff will solve the problem of poison work.

Unfortunately, requeuing work for processing introduces additional problems. To understand why, consider the case where workers are crashing for reasons unrelated to the work. Perhaps a downstream dependency is returning bad data and causing the crash. In this situation, the work queue effectively stalls, and more and more work piles up in the queue. Since no workers can make progress, even work stealing described previously won't help. Suppose the situation resolves itself and the workers can start making progress, like a traffic jam long after an accident; all of the work that has piled up in the queue means that new requests are still experiencing significant latency. This is often made especially bad in user-facing situations where the old work items are often no longer relevant, but the new work has value *if* it can be completed in time.

To address this problem of a backlog, it is often useful to actually have two queues of work items. The first queue is used for all work items which have

never had an attempt made at processing. The second queue is the “retry” queue, which is used for any message which has had at least one (unsuccessful) attempt at processing. Using this dual queue approach, in the above situation, there will be a lot of work piled up in the retry queue waiting for processing, but new work is no longer standing at the back of the line of retries. It has an equal chance of being processed along with the retry work. This two-queue approach is an example of a general priority queue approach, where different work queues have different priority and work is taken off the higher priority queue until it is empty, and then the next highest priority queue, etc. This can ensure that performance goes to where it is needed most to achieve latency goals.

Summary

This chapter has introduced the idea of a workflow. Workflows combine multiple work queues together into an orchestration of work to achieve some more complex objective. Multiple patterns for building workflows, from copying, to filtering, sharding, and merging were introduced. Finally, the important considerations of both performance and reliability in the face of slow work and worker crashes was examined. Using these patterns and error handling approaches, any complex work can be broken into an easily reasoned-about and constructed workflow for processing data reliably and efficiently.

Chapter 13. Coordinated Batch Processing

[Chapter 12](#) described a number of patterns for splitting and chaining queues together to achieve more complex batch processing. Duplicating and producing multiple different outputs is often an important part of batch processing, but sometimes it is equally important to pull multiple outputs back together in order to generate some sort of aggregate output. A generic illustration of such a pattern is shown in [Figure 13-1](#).

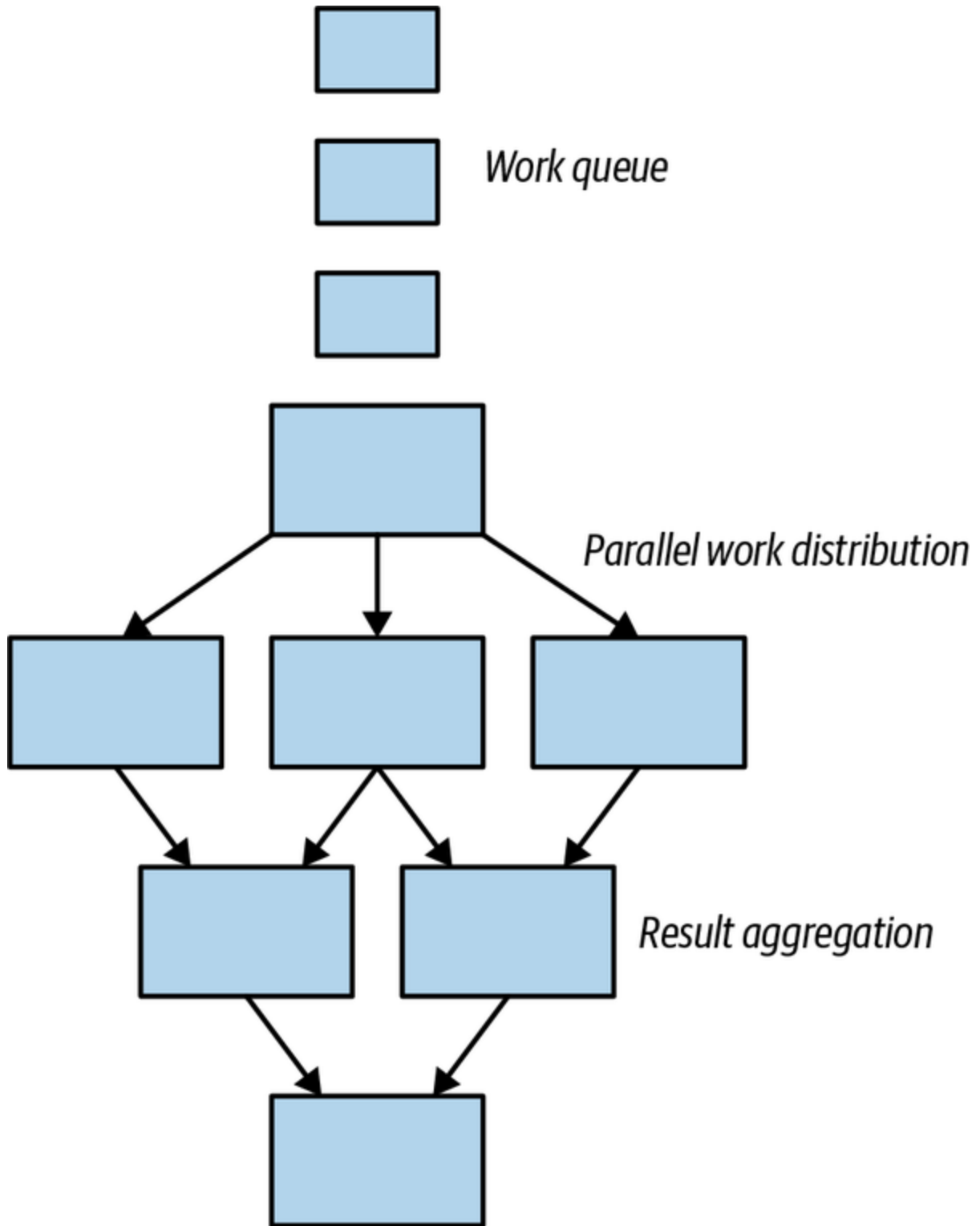

Figure 13-1. A generic parallel work distribution and result aggregation batch system

Probably the most canonical example of this aggregation is the *reduce* part of the MapReduce pattern. It's easy to see that the map step is an example of sharding a work queue, and the reduce step is an example of coordinated processing that eventually reduces a large number of outputs down to a single aggregate response. However, there are a number of different aggregate patterns for batch processing, and this chapter discusses a number of them in addition to real-world applications.

Join (or Barrier Synchronization)

In previous chapters, we saw patterns for breaking up work and distributing it in parallel on multiple nodes. In particular, we saw how a sharded work queue could distribute work in parallel to a number of different work queue shards. However, sometimes when processing a workflow, it is necessary to have the complete set of work available to you before you move on to the next stage of the workflow.

One option for doing this was shown in [Chapter 12](#), which was to merge multiple queues together. However, merge simply blends the output of two work queues into a single work queue for additional processing. While the merge pattern is sufficient in some cases, it does not ensure that a complete data set is present prior to the beginning of processing. This means that there can be no guarantees about the completeness of the processing being

performed, as well as no opportunity to compute aggregate statistics for all of the elements that have been processed.

To give a concrete example of the necessity of the *join* pattern, consider the creation of a digitally animated film. Each frame of the film is an independent work item; it can be rendered in parallel without reference to any of the other frames in the movie. However, consider transforming each frame of the movie into one second of video. You clearly need to have all thirty frames that make up that one second present before they are transformed into video.

We need a stronger, coordinated primitive for batch data processing, and that primitive is the join pattern. Join is similar to joining a thread. The basic idea is that all of the work is happening in parallel, but work items aren't released out of the join until all of the work items that are processed in parallel are completed. This is also generally known as *barrier* synchronization in concurrent programming. An illustration of the join pattern for a coordinated batch is shown in [Figure 13-2](#).

Coordination through join ensures that no data is missing before some sort of aggregation phase is performed (e.g., finding the sum of some value in a set). The value of the join is that it ensures that all of the data in the set is present. The downside of the join pattern is that it requires that all data be processed by a previous stage before subsequent computation can begin. This reduces the parallelism that is possible in the batch workflow, and thus

increases the overall latency of running the workflow, as discussed in [Chapter 12](#). This latency increase can be compensated for by trading compute for time and duplicating the processing of all of the work items to reduce the impact of tail latency.

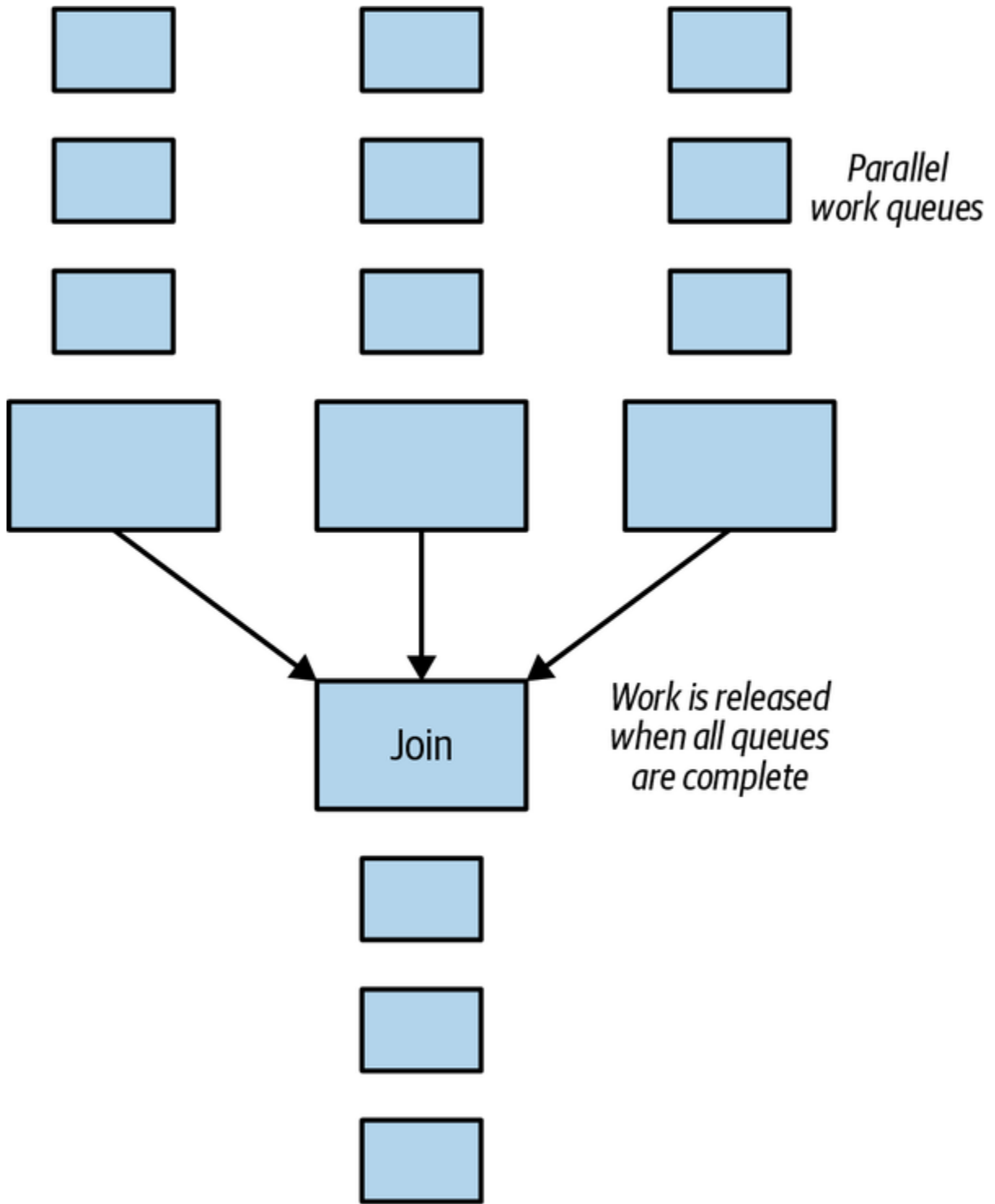

Figure 13-2. The join pattern for batch processing

Reduce

If sharding a work queue is an example of the *map* phase of the canonical MapReduce algorithm, then what remains is the *reduce* phase. Reduce is an example of a coordinated batch processing pattern because it can happen regardless of how the input is split up, and it is used similar to join; that is, to group together the parallel output of a number of different batch operations on different pieces of data.

However, in contrast to the join pattern described previously, the goal of reduce is not to wait until all data has been processed, but rather to optimistically merge together all of the parallel data items into a single comprehensive representation of the full set.

With the reduce pattern, each step in the reduce merges several different outputs into a single output. This stage is called “reduce” because it reduces the total number of outputs. Additionally, it reduces the data from a complete data item to simply the representative data necessary for producing the answer to a specific batch computation. Because the reduce phase operates on a range of input and produces a similar output, the reduce phase can be repeated as many or as few times as necessary in order to successfully reduce the output down to a single output for the entire data set.

This is a fortunate contrast to the join pattern, because unlike join, it means that reduce can be started in parallel while there is still processing going on as part of the map/shard phase. Of course, in order to produce a complete

output, all of the data must be processed eventually, but the ability to begin early means that the batch computation executes more quickly overall.

Hands On: Count

To understand how the reduce pattern works, consider the task of counting the number of instances of a particular word in a book. We can first use sharding to divide up the work of counting words into a number of different work queues. As an example, we could create 10 different sharded work queues with 10 different people responsible for counting words in each queue. We can shard the book among these 10 work queues by looking at the page number. All pages that end in the number 1 will go to the first queue, all pages that end in the number 2 will go to the second, and so forth.

Once all of the people have finished processing their pages, they write down their results on a piece of paper. For example, they might write:

```
a: 50
the: 17
cat: 2
airplane: 1
...
```

This can be output to the reduce phase. Remember that the reduce pattern reduces by combining two or more outputs into a single output.

Given a second output:

```
a: 30
the: 25
dog: 4
airplane: 2
...
```

The reduction proceeds by summing up all of the counts for the various words, in this example producing:

```
a: 80
the 42
dog: 4
cat: 2
airplane: 3
...
```

It's clear to see that this reduction phase can be repeated on the output of previous reduce phases until there is only a single reduced output left. This is valuable since this means that reductions can be performed in parallel.

Ultimately, in this example you can see that the output of the reduction will be a single output with the count of all of the various words that are present in the book. Of course, the number of times reduce is run has an impact on the overall performance of the batch processing. Too many reduce

operations cause significant wasted computation, while too few begin to resemble the synchronization of the join pattern.

Sum

A similar but slightly different form of reduction is the summation of a collection of different values. This is like counting, but rather than simply counting one for every value, you actually add together a value that is present in the original output data.

Suppose, for example, you want to sum the total population of the United States. Assume that you will do this by measuring the population in every town and then summing them all together.

A first step might be to shard the work into work queues of towns, sharded by state. This is a great first sharding, but it's clear that even when distributed in parallel, it would take a single person a long time to count the number of people in every town. Consequently, we perform a second sharding to another set of work queues, this time by county.

At this point, we have parallelized first to the level of states, then to the level of counties, and then each work queue in each county produces a stream of outputs of (town, population) tuples.

Now that we are producing output, the reduce pattern can kick in.

In this case, the reduce doesn't even really need to be aware of the two-level sharding that we performed. It is sufficient for the reduce to simply grab two or more output items, such as (Seattle, 4,000,000) and (Northampton, 25,000), and sum them together to produce a new output (Seattle-Northampton, 4,025,000). It's clear to see that, like counting, this reduction can be performed an arbitrary number of times with the same code running at each interval, and at the end, there will only be a single output containing the complete population of the United States. Importantly, again, nearly all of the computation required is happening in parallel.

Histogram

As a final example of the reduce pattern, consider that while we are counting the population of the United States via parallel sharding/mapping and reducing, we also want to build a model of the average American family. To do this, we want to develop a *histogram* of family size; that is, a model that estimates the total number of families with zero to 10 children. We will perform our multilevel sharding exactly as before (indeed, we can likely use the same workers).

However, this time, the output of the data collection phase is a histogram per town:

```
0: 15%
1: 25%
2: 45%
3: 10%
4: 5%
```

From the previous examples, we can see that if we apply the reduce pattern, we should be able to combine all of these histograms to develop a comprehensive picture of the United States. At first blush, it may seem quite difficult to understand how to merge these histograms, but when combined with the population data from the summation example, we can see that if we multiply each histogram by its relative population, then we can obtain the total population for each item being merged. If we then divide this new total by the sum of the merged populations, it is clear that we can merge and update multiple different histograms into a single output. Given this, we can apply the reduce pattern as many times as necessary until a single output is produced.

Hands On: An Image Tagging and Processing Pipeline

To see how coordinated batch processing can be used to accomplish a larger batch task, consider the job of tagging and processing a set of images. Let us assume that we have a large collection of images of highways at rush

hour, and we want to count both the numbers of cars, trucks, and motorcycles, as well as distribution of the colors of each of the vehicles. Let us also suppose that there is a preliminary step to blur the license plates of all of the vehicles to preserve anonymity.

The images are delivered to us as a series of HTTPS URLs where each URL points to a raw image. The first stage in the pipeline is to find and blur the license plates. To simplify each task in the work queue, we will have one worker that detects a license plate, and a second worker that blurs that location in the image. We will combine these two different worker containers into a single container group using the multiworker pattern described in [Chapter 12](#).

This separation of concerns may seem unnecessary, but it facilitates container image reuse. Imagine if the API to our container is an image and a box to blur. The same container that blurs license plates can be reused to blur people's faces in a different pipeline.

Additionally, to ensure reliability and to maximize parallel processing, we will shard the images across multiple worker queues. This complete workflow for sharded image blurring is shown in [Figure 13-3](#).

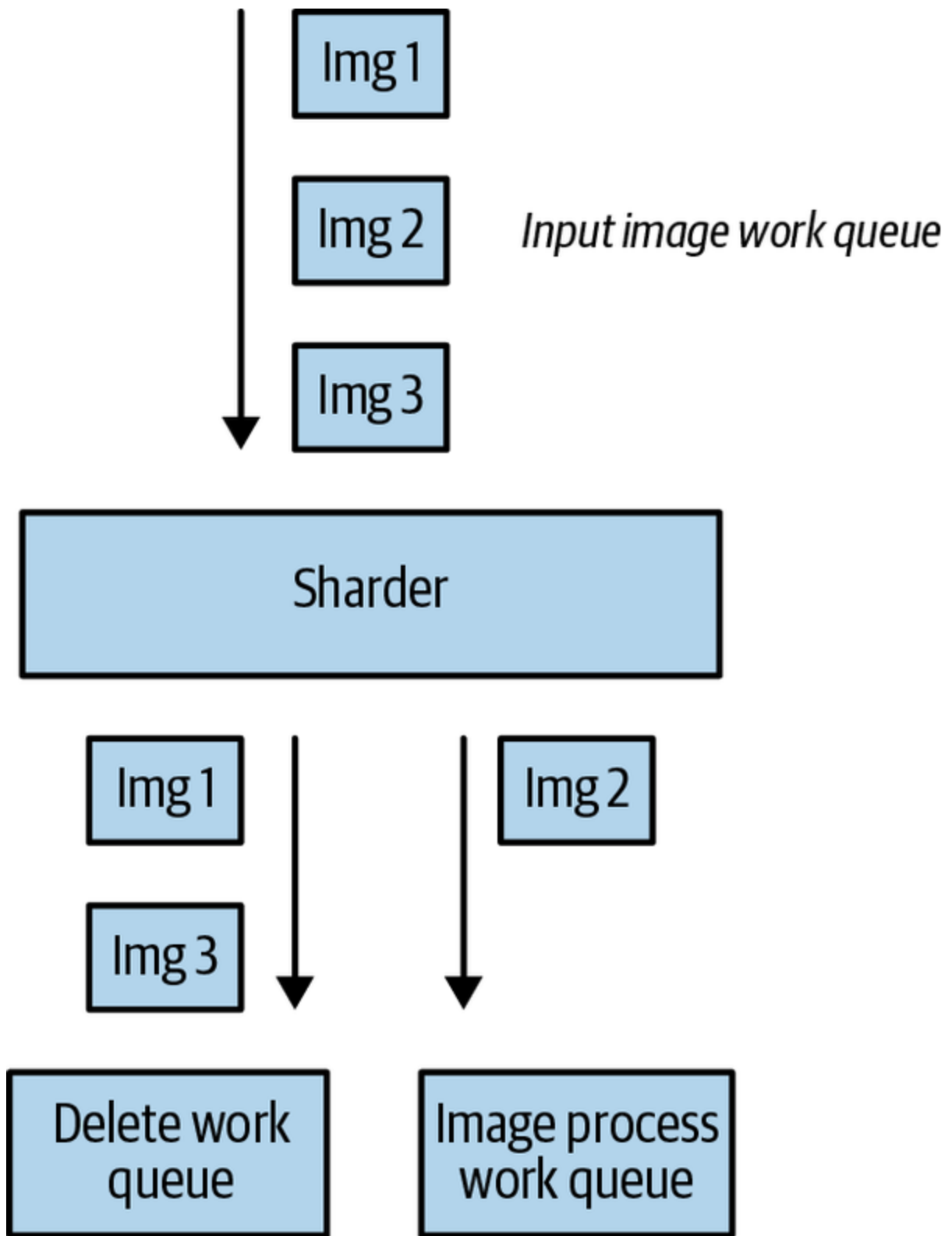

Figure 13-3. The sharded work queue and the multiple blurring shards

Once each image has been successfully blurred, we will upload it to a different location, and we will then delete the originals. However, we don't want to delete the original until *all* of the images have been successfully blurred in case there is some sort of catastrophic failure and we need to rerun this entire pipeline. Thus, to wait for all of the blurring to complete, we use the join pattern to merge the output of all of the sharded blurring work queues into a single queue that will only release its items after all of the shards have completed the work.

Now we are ready to delete the original images as well as begin work on vehicle model and color detection. Again, we want to maximize the throughput of this pipeline, so we will use the copier pattern from [Chapter 12](#) to duplicate the work queue items to two different queues:

- A work queue that deletes the original images
- A work queue that identifies the type of vehicle (car, truck, motorcycle) and the color of the vehicle

[Figure 13-4](#) shows these stages of the processing pipeline.

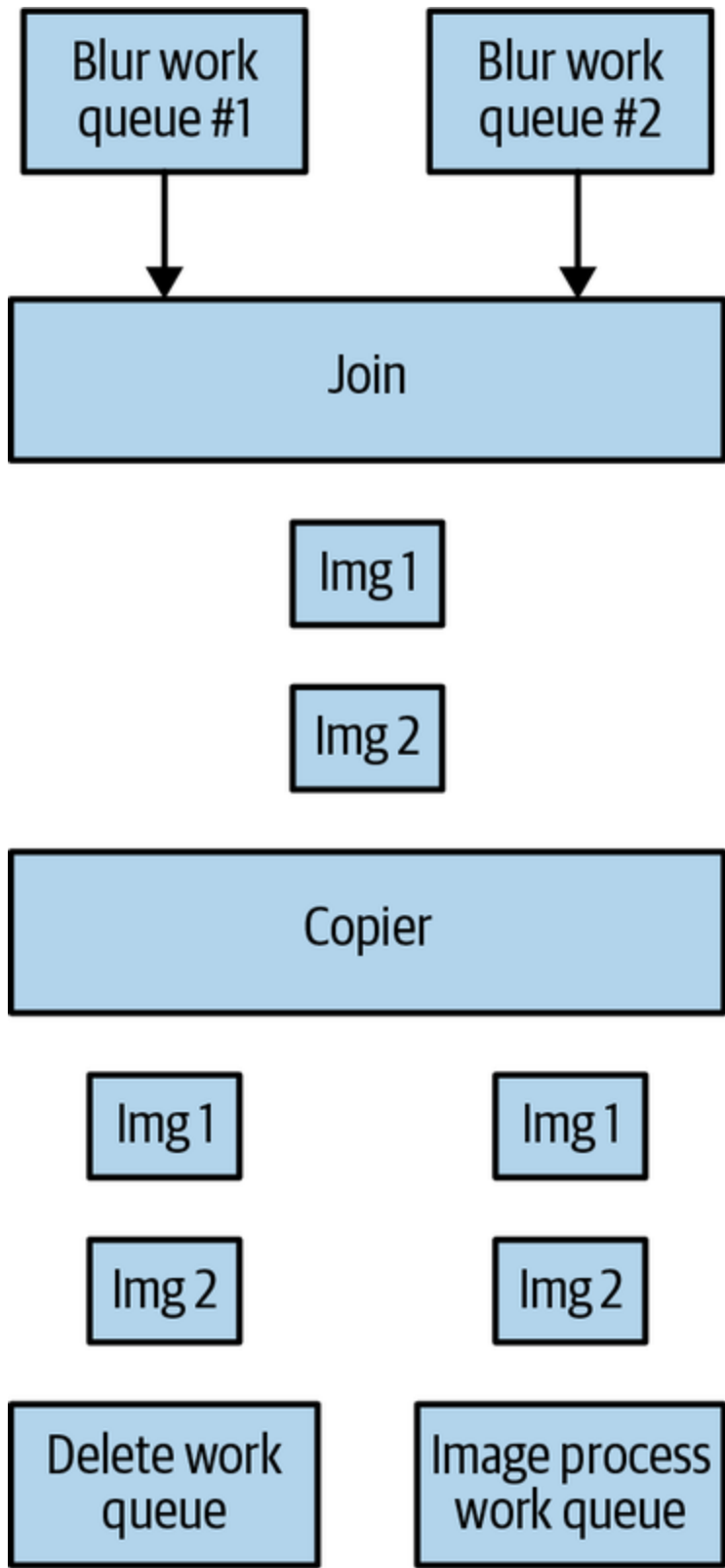

Figure 13-4. The output join, copier, deletion, and image recognition parts of the pipeline

Finally, we need to design the queue that identifies vehicles and colors and aggregates these statistics into a final count. To do this, we first again apply the shard pattern to distribute the work out to a number of queues. Each of these queues has two different workers: one that identifies the location and type of each vehicle and one that identifies the color of a region.

We will again join these together using the multiworker pattern described in [Chapter 12](#). As before, the separation of code into different containers enables us to reuse the color detection container for multiple tasks beyond identifying the color of the vehicles.

The output of this work queue is a JSON tuple that looks like this:

```
{
  "vehicles": {
    "car": 12,
    "truck": 7,
    "motorcycle": 4
  },
  "colors": {
    "white": 8,
    "black": 3,
    "blue": 6,
    "red": 6
  }
}
```

This data represents the information found in a single image. To aggregate all of this data together, we will use the reduce pattern described previously and made famous by MapReduce to sum everything together just as we did in the count example above. At the end, this reduce pipeline stage produces the final count of images and colors found in the complete set of images.

Summary

This chapter describes *coordinated batch processing*, which is used to synchronize workflows for preconditions or to combine output from previous workflows into a merged output. The *join* pattern is used as a barrier synchronizer to ensure that all of the necessary output is ready before proceeding to the next stage. Reduce combines output from multiple shards into an output that can be reduced further until the final output is ready. Sum and histogram are specific types of reduce operations that are useful for obtaining specific statistical results from your data. Taken together, these patterns for coordination in batch processing can ensure that you can build the workflow that is necessary for any batch operation or calculation you need to perform.

Part V. Universal Concepts

So far we have focused on patterns for building your applications, all the way from single nodes to complex distributed systems. In addition to these patterns, there are parts of our systems that are universal to all applications that you build. The following chapters in this section cover some of these universal concepts. [Chapter 14](#) discusses observability for your application via logging, monitoring and alerting. Observability is critical for you to understand if your application is operating correctly. [Chapter 15](#) covers AI, which is revolutionizing the way that we think of applications and user interfaces. Finally, [Chapter 16](#) ends this section by including common mistakes and errors that occur with unfortunate regularity in distributed systems that people build. No matter your application, all of these chapters will enable you to make it more intelligent and more reliable.

Chapter 14. Monitoring and Observability Patterns

One of the core differences between client applications and distributed systems is that generally distributed systems implement services. Services are always on, always available for users around the world in all time zones and ways of working. Because of the 24/7 nature of these systems, monitoring and observability become critical to building reliable systems. To deliver reliability, you must notice a problem before the customer notices a problem; and to solve any problems you find, you need to be able to understand how your system is operating. This chapter focuses on best practices for such monitoring and observability.

Monitoring and Observability Basics

Before we get into the details of implementing monitoring and observability, it is useful to ground ourselves in the core set of concepts that make up any monitoring and observability solution.

In any system, there are four key concepts which make up our solutions:

- Logging
- Metrics
- Alerting

- Tracing

We'll step through each of these in a little more detail.

It's highly likely that anyone who has built even the smallest system has implemented logging, even if they don't realize that they have. The simplest version of logging is the humble `printf` statement. Of course, there are many more sophisticated ways to do logging, but ultimately they all serve the same purpose as that print statement. Namely, they show us that a particular place in our code has executed, and they record data associated with that place in the code. Logging records data that helps us understand specific executions of our code.

The contrast to logging are metrics or monitoring. While logging is associated with a specific execution of our source code, a metric is generally related to aggregate data across multiple requests. Examples of metrics could be the number of times this particular function has been called in the last minute, or the average length of time spent in that function across all of these calls. While logging provides us a perspective to understand a specific execution of our service, metrics provide us a global perspective of how our service is executing in general.

The purpose of logging and metrics are to help us understand our systems when we are looking at them, or when we know that there is a problem. If we spent all of our time staring at graphs of metrics and logging interfaces,

that might be all we need; but of course, in real life we spend much of our time in other environments. Consequently, we need *alerting* to detect problems and notify us that we need to interrupt our lives and go look at the logging or metrics. Effectively, alerts are rules that are applied to either logs or metrics which trigger an event. Generally, this event triggers a notification which is intended to draw our attention to a problem (or potential problem) in our systems. Crafting high-quality alerts is a key part of building a reliable system.

The final component in our system relates to the distributed part of our distributed system. One of the hardest problems in building out a distributed system is understanding how all of the pieces work together, or even harder, understanding why they may fail in certain circumstances. From a naive point of view, every individual request to a microservice is unique and individual. But the truth is that from the broader perspective of the application, there is often a larger request, which is being serviced by a chain of calls through all of the microservices. *Tracing* is the act of rebuilding this context so that instead of seeing individual, unique requests at each microservice, we can understand that all of these individual pieces are part of a broader user request. This global perspective, in turn, enables us to understand (for example) why a particular user's request is running slowly or failing to work at all. Tracing takes all of the pieces of a distributed system and reconstructs the user's perspective.

In the coming sections, we'll dive deeper into each of these components and see how you can use them to build a reliable system.

Logging

Once you figure out how to log information, one of the first things that you notice in a distributed system is just how much information gets logged. The volume of logs, or “log spam” can often be a significant problem in terms of understanding a problem, or even just the raw cost of storing and searching all of those logs.

The truth is that the value of logging is very contextual. When you are debugging a specific problem in a specific component, then verbose, detailed logging can be critical to identifying the problem. On the other hand, during standard execution, where everything is working correctly, most of the logging is just wasted noise, except those logs which trigger alerts because of system errors.

Consequently, only the simplest distributed systems use logging like basic printing. Nearly every system uses some sort of logging library. These logging libraries provide important capabilities that make it much easier to deal with lots and lots of logs. The most basic capability provided by such libraries is basic timestamping. Oftentimes we are trying to understand what happened and in what sequence; and without a shared notion of time in every log line, it is difficult to know (for example) the amount of time that

passed between different logs. In addition to timestamp, most logging libraries enable the addition of other types of context to the logs. In any multithreaded system, many requests may be processed in parallel, and thus many different identical logs may be issued. To differentiate between these logs and understand how they relate to a specific request, context like the thread identifier, user ID, or request ID help differentiate between otherwise identical logs on the same server and filter to the context of a specific request. The final, and often most valuable, service provided by logging libraries is leveled logging. Leveled logs allow you to express the type of logs being emitted. The specific number of different levels often vary by library, but in general they include:

Debug

Verbose logs, generally only useful when doing detailed debugging.

Info

Often useful but not exceptional messages tied to the operation of the service.

Warning

Something that is concerning, but not necessarily fatal to the entire application.

Error

Something very bad has happened, and someone should take a look as soon as possible.

Fatal

Something unrecoverable has happened, and the application will terminate after writing this log.

Leveled logging enables you to filter only to certain types of messages, and it allows you to leave detailed logging in your code, for when it is needed, without filling up your log streams with many, many spammy log messages. Generally, your log level for an application is set to Info or Warning depending on your logging style. Debug messages are reserved for conditional activation to debug specific problems.

In addition to the request context, a valuable context for the logging library is the location of the log call itself. Typically, logging systems understand which class or component contains the log. This enables *conditionally logging* where you dynamically activate detailed debug logging for specific classes or other components on running servers. Conditional logging enables you to respond to a reported incident or a problem seen by a specific user without requiring the storage or latency of detailed logging for every request. Some care should be used when performing conditional logging, as it can significantly increase the latency of end-user requests. Nothing is worse than causing a worse incident or outage in the process of investigating an outage.

Of course, to make logging useful, you must have a clear sense of what the purpose of logging is in the first place. Ultimately, logging provides insight into the operation of your service or application. One common joke is that the way to know what to log is to remember what you were missing when you initially debugged the problem. That is, logging is often a retrospective exercise “I wish I had logged....” It goes without saying that the most useful things to log are exceptional or erroneous situations. Every error or exception should probably be logged unless you are completely confident in the error-handling code (and sometimes even then). Beyond errors, often the most interesting things to log are the things that are weird. For example, some requests are just slow. You can stare at metrics (see [“Metrics”](#)) showing that your 99th-percentile requests take a ridiculous amount of time, but without logs indicating which parts of request handling are exceptionally slow, it is hard to take action. On the other hand, just logging the play by play (“function foo was called”) is rarely going to be that useful, and it is definitely going to spam your logs. When logging, try to imagine the hardest problem you might need to debug in that particular part of the code, and write down in the log whatever you would need to successfully figure it out.

Metrics

In contrast to logging, with its focus on individual executions, monitoring metrics are designed to collect statistics over time which characterize the

general execution of your services. The focus of this metrics section will be the [Prometheus monitoring application](#), which has become the de facto industry standard. Other monitoring solutions offer similar capabilities.

Monitoring data is generally recorded over time; from this view you can see both the instantaneous state of your application and also how that state is changing over time. When monitoring your application there are three basic types of data that are interesting to record:

- Histograms
- Counts
- Values

Histograms represent a distribution of values over some interval.

Histograms enable you to understand both the average and the extreme experiences of your users. For example, a histogram of latency can show you the best 10% average and worst 10% latency that your users experienced. Such information is useful to give you an “at-a-glance” sense of how your application is performing.

Counts are monotonically increasing values that keep track of some value that can only increase. One of the most common examples of a count is the total number of requests served by your service. This number can clearly only increase over time, as there are more and more requests. Counts are also often transformed into *rates*, which are the first-order derivative of the

count and represent the rate of change of that count over time. Given a count that tracks the total number of requests, the rate could give you the number of requests per second. Counts are inherently integral (whole numbers) in nature.

Finally, there are values; these are numbers which can take on any value and can both increase and decrease over time. Common examples of values include CPU and memory usage for a service. Clearly, the amount of CPU and memory use can vary over time and increase or decrease based on the operation of the service. Values are most useful when viewed over time because they can indicate the overall behavior of the system. Steadily increasing memory usage can indicate a memory leak. Periodically spikey CPU can indicate some background process which is unnecessarily expensive.

It should be clear at this point that the main value of monitoring data is the perspective that it gives over time. Indeed, most monitoring is referred to as a *time series* representing exactly these values over time. Dedicated databases for this time series data have been developed to efficiently store and query this data. The Prometheus system comes with a simple time-series database, but most people will integrate Prometheus with a dedicated time series database. Often, a good option is to integrate Prometheus monitoring with a cloud-based monitoring as a service. At this point, most cloud-based monitoring services, for example Azure Monitor, support the ingestion of Prometheus metrics.

When it comes to ingesting metrics, Prometheus is a pull-based or scraping metrics system. Periodically the Prometheus application sends requests out to your application for the current state of all of the metrics. These metrics are stored into the time-series database for later query and recording. Pull-based monitoring works well for applications that are always running, but how can you record metrics for batch and other transient jobs that may not be around long enough to be scraped? For such jobs, you need to implement *push-based* metrics instead. Fortunately, Prometheus has a sister project, the Prometheus push gateway, which implements exactly this pattern. When you run the push gateway, it runs a dedicated server that Prometheus can scrape. Your applications can send or “push” metrics into this gateway so that they are recorded even if your application is no longer running. Combining pull-based monitoring for your long-running applications and push-based metrics for transient jobs allows you to have a complete perspective on the operation of your application.

Basic Request Monitoring

One of the first types of monitoring that most people add is for the number of requests served by your application. This is a basic statistic that demonstrates how many people (or other services) are using your service over time. The number of requests is an example of a count metric. The number of requests cannot decrease since there is no such thing as a negative request.

However, the total number of requests is actually not that interesting, what is more interesting is the rate of change of the total number of requests. Rate of change is a secondary metric defined as the difference between the number of requests at time t and the number of requests at time $t + 1$. To make this concrete, the rate of requests per minute is the total number of requests right now, minus the total number of requests one minute ago. To turn this into a graph, the rate is calculated for each previous minute moving backward and producing a rate at one-minute intervals. Of course, in this example, one minute is arbitrary; you can do equivalent calculations for whatever time interval that you want, from a millisecond to a day (or more).

Thinking about calculating the rate of requests for a millisecond demonstrates one of the challenges with rate metrics. If your server serves fewer than 1,000 requests per second, calculating the rate of requests at millisecond granularity will lead to a very spikey metric, which oscillates between zero and one (and possibly more if there is a brief surge of requests). Rates are variable and highly dependent on external factors. Consequently, it is often more useful to use the average of the rate of requests per time interval, rather than just the raw value. Averaging the rate over time smooths the peaks and valleys and gives you a more realistic picture of how your service is being accessed.

The total number of requests is a good metric to start with, but to truly understand the operation of your system, it is useful to look at more details

associated with each request. One of the most common features of a request is the HTTP response code which it returned to the users. If you are not already familiar with HTTP response codes, they are a part of the HTTP protocol that indicates how the server responded to the request. Some of the most common are 200 (OK), 404 (Not found), and 500 (Internal Server Error), but there are many more response codes for different situations. With Prometheus metrics, values can have labels which add detail to the metric. Using this capability, we can view the response code as a label associated with the request count. Using this label, we can query for the total number of requests which were served successfully (`code==200`) or the total number of requests which resulted in errors (`code==500`); we can also calculate the rate of each of these types of requests using the methods described previously. Subdividing the total request count by the response code gives us a much richer view into the operation of our application. We can also group error codes together and view how many requests were errors (codes starting with 5xx) and how many requests were successful (codes starting with 2xx).

In addition to the response code for a server request, the next most important characteristic of the request is the latency of the request, or how much time it took to process. It might be tempting to think that latency could be a label on the request count as well, but this doesn't work. Labels need to be a limited set of discrete values, while latency is a value that can take on many different arbitrary values. Request latency is a separate metric, and it is generally modeled as a histogram. Using the histogram

metric for request latency, you can understand the average experience of the user as well as the experience of users who have the slowest requests. As with request count, the request latency can also be labeled using the response code. That way, not only can you see the average experience of any request, but you can also calculate the average latency of an error, of a not found request, or any other HTTP response code.

Advanced Request Monitoring

Though total request count, the rate of requests, and latency are the most common and most generally useful metrics for monitoring requests to your server or service, there are other more specialized metrics, which can be quite useful to have a deep understanding of how your service is performing. A good example of this might be the request and response sizes in bytes for your service. Request size is useful because you can use it to correlate to slow requests (larger requests may take longer to parse and process) and also to look at it over time to detect patterns like increasing requests or response sizes over time. Like latency, request and response size are examples of histogram metrics.

Sometimes useful metrics are recorded by adding detail to how you calculate and report metrics in your application. For example, it is sometimes useful to understand the amount of time a request has spent in a queue, versus how much time was spent processing a request. This sort of information is especially useful when you are debugging why your service

is slow in processing requests. Simply seeing that latency is high will show you that there is a problem and that users are likely unhappy, but having metrics for queue time and processing time will help you understand whether the problem is that you need to scale out (queue time is too long) or if you need to optimize your code (processing time is too long). To get these metrics, you actually need to add additional metrics to your code. In this case, you would add two new histogram metrics, one measuring the time from when a request is received to when processing starts, and one measuring the time from when processing starts to when the request is completed. This system now has three histogram metrics measuring latency: total latency, queue latency, and processing latency. Metrics are cheap to add, and the additional insight that they provide is often invaluable in debugging your service. Of course, as with anything, it is very possible to overdo things, and if you are monitoring the latency of each line of code (or even each function), you're probably taking things a little too far.

Another advanced metric for requests might be to break them down by geography or customer. This monitoring can give you business insights that can help you build better products, or possibly identify abusive requests coming from specific users or locations. If you are willing to only look at coarse-grained geography (e.g., country), then it is possible to view geography as another label that you can apply to the request count metric; but more often, this sort of data needs to be obtained by querying across logs instead of looking at metrics directly. For example, in any large system there are far too many customers to use a customer ID as a label for the

request count metric. Instead, the system logs the customer ID whenever a request is processed. This example demonstrates the interplay between logging and monitoring. Monitoring and metrics can provide aggregate data that is quick to query. For detailed information, logging and log search is an essential technique that provides slower, but more rich, access to data. In this case, because the business analysis can likely stand extra latency in processing, obtaining customer usage information from log search can meet the business requirements.

Alerting

So far we've discussed all of the different ways to record information from your application's logs and metrics. This data can be critical for understanding why your system isn't behaving correctly during an outage or other incident. But how can you figure out something is happening in the first place?

Obviously, the first way we find out that there is a problem in our system is when a customer or user complains. But waiting for such *customer reported incidents*, or CRIs, is a bad experience for both the user and the person receiving the alert. Nothing hurts customer confidence like being told that they were the first one to notice a problem. At this point with our systems, every user expects that we will notice (and fix) problems in our services before the user notices that anything is amiss.

Thus, the best way to find out about a problem is via *alerting*. Alerting is the practice of establishing conditions under which the team responsible for a service is notified, typically through a pager alert, that there is a problem with the system.

Basic alerting

The most basic form of alerting is based on metric queries and static thresholds. For example, you might choose to alert if the latency at the 90th percentile in your system is greater than half a second. You might also chose to alert if the number of HTTP 500 errors reported by your system is greater than 1% of all requests. Given these rules, it's easy to see that if either occurred it would be a good idea to let the engineers know; but how do you go about determining the right alerts for your system?

The most basic way to think about writing alerts is that they define the service level objective (SLO) for your application. If you don't alert, you won't notice and so your alert thresholds define the difference between nominal and exceptional operation. Every application is different, but it is good to write down what the goals are for a "normal" user experience of your service and right alerts that fire if those goals aren't being achieved. Another consideration is the experience of your on-call engineers. Firing alerts constantly is a recipe for burnout and people quitting. Similarly, firing alerts that are false alarms ("crying wolf") will cause your on-call engineers to stop responding. Therefore, you need to balance the goals of your service

with the needs of your on-call engineers to determine the right alerts. The development of alerts is an ongoing activity throughout the lifespan of your service. As you add more capabilities and, thus, more monitoring, you should also be adding more alerting; as you get more experience with the system, you can tune the alerts to be tighter or looser depending on the needs of your users or your on-call engineers.

Alerting on anomalies

Basic alerting is great for many use cases, but sometimes it is insufficient. A great example of this is an error that causes a 100% outage for a small (1%) subset of your users. From a static alerting perspective, your system is functioning within bounds, but for those poor users in that subset your service is completely down. Static alerting assumes that all metrics are uniform across all users and service calls. However, this isn't always the case. Anomaly detection is a form of AI that can identify anomalies: for example, customer A is 100% down while customer B is working perfectly. Though alerting on anomalies is an advanced topic, it is often the only way to find a balance between alerting when there is a problem and firing lots of false alarms. As your system gets larger and more complex, anomaly detection alerting will become a critical requirement.

Monitoring and logging provides visibility into your application. Alerting tells you when you should be paying attention. Importantly, not every metric requires an alert; some are useful only for debugging and

visualization. However, the performance of your application will be defined by the quality of your alerts. Invest in alerting with the same energy you bring to designing customer-facing features.

Tracing

As we have seen in the preceding chapters, most modern applications involve requests that span multiple machines and processes. From the techniques above, you can learn how to monitor all of these components individually. But unfortunately, this service-by-service view shows you all of the different requests flowing through your system at the same time, but it doesn't do a good job showing you the path of a single request through all the microservices in your system. Request tracing correlates all of the service metrics together and gives you that end-to-end perspective.

The easiest way to achieve tracing is to create a unique correlation ID for every request as it enters your system. Effectively, this correlation ID is a number that can be used to group together logs, metrics, and other information across your application. The correlation ID can be anything you want as long as it uniquely identifies each request. The simplest correlation ID would be a large random number; a better one would be a hash function applied to unique characteristics of the original request like its RESTful path and source IP address.

Once you have a correlation ID, whenever you emit a log or a metric, you emit the correlation ID. For example, in a logging system, in addition to the timestamp and the log level, you would also log the request correlation ID. To enable you to log that ID within all components in your system, you need to pass it along with the API calls you make throughout your system.

Assuming that you are making API requests using the HTTP protocol, you can embed your correlation ID in an application-specific header, for example, `x-my-apps-correlation-id`, and modify your code to read from that header and populate a request context object with that ID. Once you have correlation IDs populated throughout your logging and metrics, you can group that information back together to visualize the path of a single request through your entire system.

If this sounds like a lot of work to implement and get right, you're right, it is. Fortunately, the [OpenTelemetry project](#) has taken care of much of the heavy lifting for you. OpenTelemetry has SDKs for all popular languages that make it easy to integrate request tracing into your application. It has a vendor-agnostic philosophy that allows it to integrate with numerous backends for metrics and logging. Additionally, numerous visualization and debugging tools have also integrated with OpenTelemetry to provide rich introspection capabilities. In nearly all cases, integrating with a community-driven open source project like OpenTelemetry for request tracing is a better idea than building your own.

Aggregating Information

Once you start monitoring, you will discover that monitoring can generate a tremendous amount of information. Efficiently maintaining necessary information as well as being able to quickly sift through it to find the right information for your current issue becomes an important challenge.

Aggregation enables you to group information together so that it is easier to understand or more efficient to store.

The first form of aggregation that most people begin with is querying logs across multiple processes. In [“Tracing”](#) we discussed how OpenTelemetry provides a request-oriented view of your data, but that’s not the only aggregation you might want to perform. If you have a component that has been replicated for scale, you may want to search for instances of a specific error or failure across all of the replicas.

Fortunately, there are numerous tools that make it easier to group logs across multiple containers in Kubernetes. One of the easiest to use is a [tool like `ktail`](#), which extends the traditional `kubectl` log interface to combine logs across multiple pods. More sophisticated tools ingest logs into a [search index like Elasticsearch](#), which makes it possible to run arbitrary queries over your logs, just like you would with web search.

Setting and maintaining a log index is complicated and error-prone, but fortunately, at this point all public clouds and many startups offer log

ingestion and search as a service. Similar services are also available for time series metrics. Whether you are building in the public cloud or your own infrastructure, using a service for something as critical as your logs is the right choice more often than not.

In addition to storing your logs and metrics in systems designed for efficient storage and querying, sometimes it is necessary to reduce the information being stored. This can be referred to as downsampling or aggregation. The simplest form of downsampling for metrics is to just store the metric less often. For example, if you are recording the metric every second, after a week you might reduce that to once per minute. Even this simple change reduces the space necessary by 60 times. Of course, simply dropping the sample rate can cause you to lose information. Another option would be to use the average value over those sixty seconds instead of an arbitrary instantaneous value. This simple kind of downsampling can be used for logs. The simplest approach is to keep only a certain class of logs, such as errors, while dropping less important information. You can also just keep a fraction of the logs, though this can be very lossy in terms of information. Finally, with more effort, you can develop application-specific aggregations that maintain the information that is relevant to your application while compressing the data used to store it.

Though downsampling is often a good solution, if you want to reduce costs while maintaining full data fidelity, perhaps for compliance or security, you can instead change the accessibility of the data. Uploading logs to cloud-

based “cold” storage can significantly reduce the costs of storing the data, while making it slower and harder to query information from those logs. This can often be a good solution when data needs to be retained for long periods of time, but is infrequently used. Some logging as a service solutions will implement this sort of data tiering for you automatically.

Summary

Monitoring is a critical part of any distributed system. Though it doesn't contribute to making the system operate correctly, when the system is not operating correctly, it is the key component which enables us to understand what is failing and how to correct it. Learning how to correctly monitor and observe your systems is critical to ensuring that you can rapidly restore reliable operation in the face of a problem or outage.

Chapter 15. AI Inference and Serving

In the last few years, AI has become a key part of many different types of applications. Though the basics of neural networks and machine learning have been around for decades, in the last decade advances in deep learning and large language models (LLMs) have created a phase shift in the quality of models and the applications that are possible for AI. More crucially, these systems have captured the imagination of application developers all over the world who see limitless ways to apply LLMs to their particular business domains.

AI and machine learning is a complex topic that can take years to master, but fortunately, with the assistance of libraries and pre-built models, it takes significantly less time to begin to incorporate intelligence into your application. This chapter does not attempt to make you an AI expert, but it can serve as an introduction to the concepts and approaches for using AI in your system.

The Basics of AI Systems

Before we get started on the details of using AI in your system, it is useful to get a grounding in the core concepts that make up AI application. The place that most people start is with a model. A model is a collection of numeric weights that encode the knowledge in a neural network. In modern

LLMs, there are trillions of these weights. As a rough definition, you can think of the model as a function that takes a collection of inputs and transforms them into some output.

Unlike a traditional function in a programming language, however, a neural network model is learned via training. Training is the act of taking large amounts of training data and training the model from this training data. The training data contains pairs of both inputs and outputs. When training happens, the input is fed into the existing model, and its current output is observed. The current output is compared to the expected output in the training data. The error between the expected output and the observed output is fed back through the model in a single training iteration. This process is repeated over and over again until the model correctly outputs the expected training outputs. This training process is computationally expensive and uses dedicated hardware.

Because of the cost and complexity of training these LLMs, more recently people have used fine-tuning to refine foundational models like ChatGPT. Fine-tuning is the process of taking a general-purpose model and refining it to better match your application. Fine-tuning generally uses smaller data sets and less computation so it is more efficient from a cost perspective.

Once you have a model trained, it can be put to use within your application. While training evaluated the model with known inputs and expected outputs, inference is the process of evaluating the model on user inputs

where the output is unknown. Inference is typically implemented as a RESTful API, which you can call with the user's input.

Many cloud providers provide inference as a service. Such solutions can make it significantly easier to get started incorporating AI into your application and often allow access to models that may not be available for your own usage. However, some applications have data privacy or security requirements that mean they need to host inference on their own servers. We'll discuss how this is done in later sections.

For LLMs, the final part of inference is the prompt itself. When you chat with an LLM, it may seem as if your query text is sent directly to the model, but in most cases it is wrapped as part of a larger text that is called the prompt. The prompt provides context and instructions to the model that are not included in your specific query. For example, a prompt might add your location or other personalization information that is known about you to your query. The structure of the prompt is critical in getting good responses from an LLM. The act of creating a good prompt is known as prompt engineering. In addition to the examples above, prompt engineering can be used to add additional data from traditional data sources and to ensure that the responses from the model adhere to your application's requirements for accuracy and stability.

["The Basics of AI Systems"](#) described the components of an AI application. The following sections will get into more details about how the application

can be built.

Hosting a Model

Building a model is a large, complex task that could fill an entire book (or more) and is thus outside of the scope for this chapter. Even if you are interested in doing your own training or fine-tuning, you are encouraged to begin by using pretrained models so that you can get a sense for how well AI works with your application. Not every application is a great fit for the current state of AI models, and thus, before investing the time, energy, and money in training, it makes sense to evaluate your overall approach.

When you are looking to host a model, the first thing to consider is the computational requirements of the model and your application. If your application is going to be used interactively by a user, the latency of the responses is critical to the quality of the application. Generally, users begin to notice latency at 250 milliseconds and start turning away and doing other tasks when latency reaches more than a few seconds. Thus, in interactive inference, performance is critical.

Typically, LLMs require high-performance dedicated GPUs to achieve the required latency. Such GPUs are expensive to purchase for your own hardware or rent from the cloud; further, given the intense interest in AI, the chips themselves have been hard to obtain from time to time. LLMs

typically cannot run on the hardware profile of a mobile device such as a phone or tablet. If your application is intended for a mobile use, you will need to run the inference in the cloud and access it from the mobile device over the network.

The challenge of the cost of inference has led to the development so-called “small language models.” These models, like Microsoft’s Phi family of models, use much more focused training data to achieve reasonable performance with many fewer weights (billions versus trillions). Though their scores on AI benchmarks cannot compete with larger models like ChatGPT, the reduced size means that both the cost and latency of inference can be dramatically reduced. For many applications, the trade-off is worth it, and small language models (SLMs) can deliver acceptable quality at a much lower cost. Furthermore, since SLMs can run on a mobile device, they also can help address concerns from users who do not want to share their data with a cloud-based model.

Distributing a Model

So far we’ve talked a lot about models for both training and inference, but we’ve had little discussion of how the models themselves are actually stored to file and loaded for processing. There are several different frameworks for performing training and inferences (we’ll discuss them in a coming section), and each framework has its own file format; for example,

TensorFlow uses the TF2 file format. It's fine to use a framework-specific format if you don't plan to distribute your model and you don't expect to ever change formats. However, for most users a framework-independent open format for models is the best choice.

The most popular open model format is ONNX (Open Neural Network eXchange), sponsored by Microsoft, Facebook, and Amazon and used by thousands of open source developers around the world. Models that are stored in the ONNX format can be used in all of the popular frameworks for inference and learning and are supported by various model "hubs," or galleries of popular models.

For many users, especially when you are getting started, using someone else's open source model is the best way to start performing inference, much like cloud native container users start downloading container images from the Docker hub. These model hubs provide easy access to the most popular open source models. One of the most popular model hubs is called Hugging Face. Hugging Face includes not just the model distribution, but also code to make it very easy to download and start using the models themselves. Nearly the entire AI ecosystem uses Python as the language of choice. Getting started with a model from Hugging Face is as easy as a one-liner of Python code.

The models stored in these hubs can be quite large; and thus, while you can download them every time your application starts up, you probably don't

want to, as it can add minutes of time to your application startup. Instead, the best pattern is to cache the model locally, either within a shared filesystem or an in-memory key-value store. Once you cache your model, all of your instances for inference can load from the same cached model. When you restart your application because of failures or new software releases, you don't have to delay to redownload the same model over and over again.

The final consideration with model distribution is safe deployment of new models. Though changes to models typically happen less frequently than changes to your code, you will make changes to the model over time. Just like safe deployment of your code, it is critical that you perform safe deployment of your model. Changes in your model can have significant and unpredictable impact on the quality and reliability of your application. To limit these risks, you should follow the best practice of progressive exposure and start by using the new model on only a very small subset of your users, typically tied to a percentage of users or a specific geography. As you gain confidence that the model is working correctly, you can gradually expand it to more and more users until ultimately all of your application is using the new model.

Development with Models

The complexity of inference means that it requires significant compute capacity. Whether you are hosting your own models or using a cloud-based model as a service, this means that every inference is expensive. Unless you are specifically doing development related to the quality of your inference (e.g., prompt engineering), it probably doesn't make sense to pay the costs of a full model when you are working on the user interface or other parts of the service which are not directly related to the AI.

You should already be using a RESTful web API to perform inference, whether with services like Azure machine learning or models you host yourself. You can use this interface to hide the details of the specific model being used for inference and thus save costs when you don't need the full model.

In this approach, you develop a parameter to the API, which indicates which model to use. If you are using a cloud-based API, you may need to develop a wrapper RESTful service that provides this switch. When you deploy this compatibility interface, you choose which model to target. In development and testing environments, you can create a Kubernetes Service resource which points to a cheap SLM; whereas in production environments, you can use the full model. There are already several open source projects out there which provide generic inference APIs that can span a wide variety of different models.

Similarly, when performing continuous evaluation and automated unit testing of your application, it makes sense to deploy smaller, cheaper models, unless you are specifically evaluating quality.

Retrieval-Augmented Generation

Users interacting with AI systems expect that they are capable of understanding the context of the specific user, as well as the latest information available in the world. Unfortunately, because of the nature of AI models, the models themselves are fixed at a specific point in time when they were trained. Because these models are static and based on generic information, providing responses that are specific to the user or reflect the current state of the world are challenging. Retrieval-Augmented Generation (RAG) is a technique developed to handle these challenges.

With RAG, the user's prompt is augmented with traditional queries to provide the necessary context to correctly deliver an answer to the user's input. Consider, for example, the query:

Prompt: Who is the closest friend to my current location?

It is clear that a generic LLM has no knowledge of either who the person's friends are, nor their current location. We need RAG to solve this problem.

When implementing a system with RAG, in addition to the user's prompt, the system performs two independent queries. The first might be a traditional database query across the user's contact list to determine the complete set of friends. The second query might be to their phone's location services to determine the user's current location.

The results of these two traditional queries are combined with the user's prompt and then sent to the model. An example RAG prompt might look something like:

Prompt: Given a set of friends with `#{address}` and a current `#{location}`, who is the closest friend to the current location?

We can see how the personalized and up-to-date information provided by the RAG retrievals are combined with the user prompt to provide the LLM with sufficient information to correctly respond to the user.

RAG is a great technique for experienced developers who may not have lots of AI experience to develop sophisticated AI applications. By combining traditional database queries with natural language prompts from users, very successful natural language interfaces can be built that feel very personal. A further benefit of the RAG approach is that it respects user privacy. None of the user's personal information is encoded into the LLM, where it might accidentally be revealed to other users. Instead, the information is only accessible to the user that has access to the information, and provides it to

the model in the form of an augmented prompt. Because of its explainability and privacy-protecting features, RAG is one of the most popular techniques for chat-based AI systems today.

Testing and Deployment

At this point, the idea of testing our services is well understood and accepted as a required practice if you want to maintain a reliable and well running service. But what does it mean to perform a unit test in the context of an AI application when making changes to the prompt can have significant impact on the different responses that you get from the model?

The first important mind-shift that must be made when testing AI applications is the switch from correctness testing to statistical at-scale quality testing. When we were taught to write unit tests, we were taught to evaluate whether the output of the function that we were testing was correct. Indeed, there are whole frameworks dedicated to expressing the expectation that `value(A).equals(B)`. Such tests do not work for AI applications.

Instead of looking for exact matches, we are looking for our tests to evaluate if a response is “good enough.” Once we shift our minds from “correct” to “good enough,” we realize that evaluating a single input is no longer acceptable. As the model changes, the response to any one input may

change dramatically. Indeed, while a change may make the response to one type of input dramatically better, it may make the response to many other inputs dramatically worse.

Thus, to correctly test our AI applications, we have to consider their performance across a large selection of prompts and evaluate if, on average, the change improves or harms the quality of the responses. If a change has zero or positive impact on the overall quality of the responses, the change passes the test. If the quality of the responses is decreased, the test fails.

But then to actually implement such a test, we need a way to assess the quality of a response. This task itself can be a challenge. Obviously, it is far too expensive to have humans evaluate the quality of each response—some automated solution is required. Fortunately, LLMs themselves can be used for some of this evaluation. Just like you used the model to answer the user's input, you can likewise ask the model if the answer it gave is a high-quality answer. Your prompt looks something like:

Prompt: Given the following input: `#{input}` is the response: `#{response}` a high-quality response?

This approach may seem like giving the inmates control of the asylum, but it actually works well in many cases.

In addition to such AI-driven quality testing, before you release a new code or prompt change, it is critical that you incorporate user feedback signals

into your safe deployment. While, in other systems, you may look at errors and latency to determine if a release is safe to continue, when rolling out an AI application, you must also measure and evaluate if your users continue to be happy with the responses they are receiving.

AI changes the way we build applications, and thus, also changes the way those applications are tested. However, it does not change the criticality of testing and evaluating every change you make to ensure it does not impact the overall quality of your application.

Summary

In just a few years, AI has transformed both our imagination of what our applications could be, as well as our users' expectations for how they can interact with those applications. However, at the end of the day, AI inference is just another function that is provided by a distributed system and delivered to our users. This chapter provides an introduction to the core concepts and techniques for building AI applications that will enable anyone familiar with distributed systems to augment their distributed applications with AI.

Chapter 16. Common Failure Patterns

So far this book has covered various patterns to help you build your distributed system. This chapter is going to be a little different. Instead of helping you know what to do, it is intended to help you know what *not* to do. Over numerous years of developing, operating, and debugging systems, certain kinds of problems repeat themselves. These patterns are divided into mistakes that are made in building the systems, as well as common ways in which systems fail. By understanding both what not to do and what to try to prevent, we can learn from these shared mistakes and prevent them from repeating in the future.

The Thundering Herd

The thundering herd derives its name from the metaphor of a bison or other large animal on the prairie. Individually they may be manageable, but when moving together, charging, they are capable of destroying anything they are directed toward. The easiest way to understand the thundering herd is to imagine yourself interacting with a website that is not behaving properly. You attempt to navigate to a particular location, the loading progress bar spins slowly, not making very much progress, eventually you become impatient and you hit the reload button. You may not know it, but you have become the thundering herd.

Any particular application has a maximum capacity. Typically we try to size our applications so that its maximum capacity is greater than any load that it experiences, even at its most busy. Unfortunately, sometimes, because of failures, lost capacity, or unanticipated demand, the requests sent to a service exceed its ability to service those requests. Let's call the size of this overload traffic X requests per second. Being overloaded is bad; many, if not all, of those X requests per second time out or fail, but what happens next is even worse. In the next minute, those same X requests become $2X$ requests. This doubling is the result of any net new traffic (X) as well as all of those previous requests being retried. The result is even more failures, even more retries, and even more new requests. What was already a bad situation has become irrecoverable. This is especially true when there are multiple chained calls and multiple retry algorithms involved. The amplification of one request into many requests can rapidly overwhelm a system.

When we build our systems, we build in retry in order to handle when requests fail, but if we blindly retry when we see errors, we make the thundering herd worse and worse. On the client side, the first way to handle this is to use exponential backoff. Instead of immediately retrying, the client waits a period of time before trying again. Every time the client sees an error, it doubles the time it waits.

Exponential backoff is good, but it is imperfect; in addition to exponential backoff, it is also very useful to add *jitter*. Jitter is a small amount of

randomness which spreads load across time. Without jitter, a situation can occur where everyone fails at the same time, waits the same amount of time, and then hammers the service again at the same time. Jitter is especially important in situations where programs are talking to other programs. Humans are sufficiently random that they add their own jitter, but unfortunately, machines are not.

The final and most comprehensive way to solve the thundering herd is to add a *circuit breaker* to your client. The circuit breaker is something that trips when error rates exceed some threshold and stops all traffic for a period of time, giving the system time to recover. Finally, to aid in recovery, sometimes it is also necessary to only gradually let traffic back into the system. Many systems can be stable under high load but must be brought up to that load level gradually. Dumping 100% of the traffic on a server all at once can simply reintroduce the thundering herd.

The Absence of Errors Is an Error

We will move from problems of too much traffic to problems caused by too little traffic. When building a system, it is common to build monitoring and alerts to fire when there are too many errors in the system. Obviously, too many errors is a problem that requires a person to look into the system, determine the cause of the errors, and restore the service. But what about too few errors? Though it can seem counter-intuitive, some small number of

errors is the steady state for most distributed systems. It is generally very hard and not worth the effort to prevent any errors from ever occurring; thus, there is a low level of ambient errors that are handled by retry and other error-correction systems. Consequently, the absence of *any* errors is more likely to indicate a serious problem rather than that everything is awesome.

To understand how this can happen, imagine monitoring a system which adds subtitles to movies that are uploaded to a storage bucket. Whenever a movie is uploaded, the system performs speech to text and translation to add subtitles and then stores the new movie back into the storage bucket. Imagine what happens when the process that uploads movies accidentally loses permissions to upload those movies. If you are only monitoring for conditions where errors are greater than some percentage (say, 10%), then you will never alert for this condition. If the uploader cannot upload movies, then no movies are being processed, so no errors can occur, so your error rate is 0%. But clearly, if your uploader can't upload movies, your system is broken. Alerting on both too many and too few errors (or too few requests generally) will enable you to catch (and fix) such problems in your systems.

“Client” and “Expected” Errors

The next pattern considered is also related to errors in the system, but this time related to ways in which we feel OK ignoring errors. Many systems take in user input and requests for processing. In such systems, it is possible for users (or clients generally) to send requests which are invalid or unprocessable in some way. When calculating the reliability of a service, it's clearly problematic to treat errors caused by bad client requests as true errors, since the service isn't in control of what the clients send. While this is true in general, in practice such "not my problem" buckets become convenient places to ignore true system errors. Imagine, for example, something as simple as an authorization error. Certainly a user not being authorized to make a request is a "client" error and doesn't indicate a problem with reliability. But what if suddenly *all* users are unauthorized? That's probably a problem with our authorization code. But if you treat all unauthorized errors as "user errors" and you don't look for anomalies like all users failing authorization, you probably won't alert when you break your authorization code.

The same thing can be true of "expected" errors. I mentioned in ["The Absence of Errors Is an Error"](#) that there's a certain level of errors that are expected in the system, but for synthetic requests that you create, that's not true. When monitoring a system, it is also important to monitor real client requests where some small percentage of errors is expected and also to write *synthetic* or system-generated requests, which you control entirely. With synthetic requests, you control both the client and server side of the interactions and, consequently, there should never be any "client" or

“expected” errors for those requests. By combining monitoring of real traffic with monitoring of synthetic requests, you can quickly identify situations where your code changes are causing errors which would otherwise be ignored as client errors.

Versioning Errors

Whenever you are building software, you are going to need to iterate and make changes to that software; but clients require and expect consistency in how they interact with your systems. If you need to update every client at the exact same time as you update your system, you haven’t actually built a decoupled, distributed system. Any system is made up of the external API that it exposes to clients and the internal in-memory representation of that API. At first glance, it seems that the best solution is to make these two representations the same. If they are different, then translation logic needs to be applied to take the external representation to the internal representation and vice versa. And of course, when you start out, the external and internal representations are identical.

In practice, it turns out that separating the internal on-disk or in-memory representation of your API from the external client-perceived representation of your API pays immense dividends. For starters, it makes it relatively easy to have multiple different external client API versions implemented by the same internal in-memory version. This means that different clients can

talk to you using different versions of your APIs, and you don't need to tightly synchronize your clients and your application. Additionally, the separate internal representation means that it is easier for you to iterate on your API implementation; adding, removing, or merging API fields as necessary to support your application can be done without the client noticing as long as you maintain the translation logic between external and internal representations.

Though the benefits of this separation are often seen in supporting multiple clients, the same can be applied to your internal storage versioning.

Ultimately, your application will also need to store the objects in your API in some data store. This storage also needs to be versioned. If it is tightly coupled with a specific version of your code, it can make it very difficult to roll out changes to your storage layer, or roll back code when there are bugs.

Even though it may seem overly complicated to begin with, building every application with an external (client) version, an internal (in-memory) version, and a storage (on-disk or database) version as well as the logic to translate between them pays significant dividends in decoupling and agility that will benefit your application in the long run.

The Myth of Optional Components

Distributed systems are organic systems. We may design them in one way to start, but over time and in reaction to outages, scale challenges, and business changes, they morph and adapt to meet new requirements. One of the most common changes is the addition of caches in various locations to improve performance and reduce load.

Typically, when these caches are added to the system, they are treated as “optional” components. After all, a cache is just a performance improvement. If the system needs to, it can always obtain the data from the source of truth. The problem with theoretically optional components in your system is that, over time, they become required parts of your design.

Consider adding a cache to a system. It is an optional performance improvement when originally added. However, as the load on the system grows over time, its performance becomes more and more dependent on the presence of the cache until the system can no longer meet its performance goals without the cache.

Unfortunately, this increased reliance often goes unnoticed, and the overall reliability of the caches in the system is not maintained in correspondence with its increased criticality to overall system stability.

One of the most common ways that this manifests is in the difference between a local and a global cache. A local cache, as the name suggests, is a cache that is maintained locally in the memory of your application, often as a simple hash table. Such caches are very easy to implement.

Unfortunately, as the system grows, the overall size of such local caches has to grow proportionally, and eventually the overall memory demands of the system become too great to sustain the cache. Furthermore, there is a tendency to add many such in-memory caches within a single application because it is so easy to do. Consequently, the memory usage of such caches is difficult both to visualize and manage.

Additionally, as discussed in [Chapter 15](#) on caching, local caches are very bad at optimizing memory usage. Consequently, if you ever find yourself adding a local “optional” cache or any other theoretically “optional” component to your system, accept that you are actually making a permanent (and very required) change to your overall distributed system that deserves the attention of any other significant change or refactor.

Oops, We “Cleaned Up” Everything

In any real system, it’s an unfortunate truth that errors occur. Bugs and failures are bound to happen. Given this, it is often important to consider how errors and failures might impact the overall state of the system that we are building. When doing this, it is important to think about more than just the operation of the individual pieces that make up the system, but also to think in terms of how all of these pieces interact together to manage the entire distributed system. Failing to anticipate how these systems might interact together in the presence of a failure is a common cause of severe

problems. One of the most severe is a runaway deletion of a system because of some sort of unanticipated interaction effect.

Deleting everything in your system seems like such an extreme failure that it is hard to understand how it might happen by accident via a minor bug. Consequently, it is useful to examine real-world examples of how such a thing might happen.

An example is a photo storage system. Imagine that it has four components:

- A database that stores user information
- A frontend RESTful API server that implements the user API
- A file storage system where all of the photos are stored
- A garbage collection system, which cleans up photos for users after their accounts are deleted

In normal operation, a user initiates an account deletion through the website, and the user is removed from the database. Then, for each photo stored in the filesystem, the garbage collection system looks up the user in the database. If the user can't be found, the photo is deleted. This garbage collection system exists to keep the system compliant with data privacy laws as well as to ensure photos don't "leak" and cause infinite growth in the filesystem.

Now consider a piece of code written in the frontend RESTful API to look up a user. It initiates a connection to the database, looks up the user's

information, and then returns it to the caller. But what if the database is unavailable for some reason? Suppose the person who coded that piece of logic chooses to return a 404 indicating that the user couldn't be found. "Not Found" is perhaps not the best error to return in this case—500 internal service error is definitely better; but it is hard to see how this error code is important until you think about the garbage collection system. When the garbage collection system inquires about *any* user, they will all appear to be missing, and the garbage collection system will delete *all* images. Fortunately, because people anticipated catastrophic problems, the photos were restored from backups; but the service was down for many hours while these backups were restored from cold storage. During this period, user confidence in something so deeply personal and important as your family photos was shaken, and the service had to work very hard to restore confidence.

So what went wrong? There are secondary basic failure points in this system that caused the catastrophic failure. The first is a human failing. Namely, it is hard for any human to keep the full context of a distributed system in their head at all times. Especially in a situation where one team may have owned the user API system, while a different team, possibly in a different geographic location, owned the garbage collection system. It is tempting to focus on this human failure. The developer made a mistake and "caused" this outage. Unfortunately, human failures are an inherent part of distributed systems; and ultimately they cannot be fixed, only prevented.

Humans, regardless of their seniority, will make mistakes. Our systems must anticipate and prevent the effects of those mistakes.

This leads us to the second failing: the process or technical failure in the system, namely, rate limiting and a circuit breaker in the garbage collection logic. In the system under normal operation, there is always roughly the same number of users deleting their accounts. Let's say that one percent of all users delete their accounts in a given day; this will lead to a relatively constant rate of image deletes. When this bug occurred, the rate of image deletes increased by 100 times. This is clearly unusual, and the system should have detected and prevented such a high rate of deletes. The first systematic improvement would be the addition of throttling to the deletes. The throttling sets an upper bound on deletes per second and would have dramatically slowed down the rate at which all of the photos could be deleted to give humans a better chance to react and stop the process. The second is a "circuit breaker," much like the circuit breakers in our houses; when this high rate of deletes was hit for an extended period of time, the garbage collection system should have stopped itself from performing *any* deletes until a human reset the breaker. Combined, while these technical changes couldn't prevent there being some impact from the human mistake, they would dramatically reduce the impact on both the customers of the service and the brand of the service itself.

Such accidentally "we cleaned up everything" scenarios are actually surprisingly common, because as developers we tend to focus on the happy

path where everything is working correctly. In that world, the call to the user API can never return a wrong answer. Experience in distributed systems teaches us that we always need to be thinking about a world where things are going right, but also what happens when things go wrong.

Challenges with the Breadth of Inputs

One of the most disappointing kinds of failures is the failure that slips through all of your testing and goes undetected until a customer notices it. Such failures are frustrating to your customers. “Don’t you test your code?” is a hard question to answer well in such cases. They are equally embarrassing because often they sit in your codebase for a long time before someone notices and/or complains loud enough to get you to notice.

Sometimes these errors are undetected because it takes a very rare confluence of events to make them happen, e.g., tricky race conditions that occur once in a blue moon. Such bugs are actually significantly less likely to frustrate an end user; they just look like flakiness. We have all been trained to “reload and try again,” which generally fixes such bugs.

The bad ones are the ones which occur for specific users 100% of the time, but only for a small number of users. I typically call these problems “compiler” problems, because they typically occur when there is a very broad set of allowed inputs to our system. In such a system, very specific

combinations of input can cause problems 100% of the time, but only certain users present such inputs.

These are called “compiler” problems because the compiler is one of the first programs where such problems manifest themselves. For any given programming language, the space of possible legal programs is effectively infinite. Given enough programmers working on enough programs, sooner or later, one of them will write a program that is by the book legal, but exposes a bug in the compiler that causes it to crash. Sometimes these inputs are the product of random chance and human nature, but more and more often these inputs are created by fuzzing programs, special purpose code that fire random data at APIs in the hopes of causing crashes to deny service or exploit weaknesses in the APIs. An (in)famous version of such attacks were the SQL injection attacks that were typical of the early web, where bits of random SQL (e.g., `' ; DROP TABLES '`) were provided as inputs to places where no developer could reasonably expect SQL statements (e.g., a credit card number). Though, by now SQL injection attacks are largely a thing of the past, accidentally breaking legitimate users or randomized “fuzzing” attacks are still quite common.

Ultimately, this failure represents a failure of coverage in testing. If the surface area of a program is completely tested, such failures can’t happen; but the space of valid inputs for many APIs is infinite or near infinite. How can you ensure coverage of your testing in such a situation? There are two basic solutions.

The first is to record a representative sample of real-world inputs. This sample can never be exhaustive, but if you record (for example) all user inputs over the last two months, you can be reasonably sure that you are unlikely to break a legitimate user. When you are doing this recording, though, you need to be careful about both where and when you record it. If you have a global service, but only record inputs in North America, you will likely miss many bugs in inputs with Asian characters. Similarly, if your input varies between night and day, and you only record at a certain time, you will miss variation in your inputs due to the time of day. High-quality coverage in testing only comes when your test data is representative of *all* of your users.

The second solution is to use fully randomized or “fuzzed” data for your inputs. These tests can be significantly more comprehensive, but they are also much harder to create. For a simple API that perhaps only takes a few integers as parameters, it is easy enough to generate random numbers, but for more complicated APIs with richer semantics, you may need to write custom random input generation logic (for example, something that generates random but valid IP addresses). Lately, innovation in the space of LLMs and generative AI makes it possible to generate valid but random inputs for even more classes of data.

The combination of testing previously seen inputs as well as using fuzzed data can help ensure that your new code won’t break existing users and that

it is hardened against possible attacks via random or maliciously crafted command inputs.

Processing Obsolete Work

We've all been faced with an unresponsive computer system: an email system where searching isn't working, a retail site which refuses to load the next page. This chapter is full of the many different ways in which systems can fail to operate correctly. Faced with these failing systems, what do we all do? We hit the *reload* button. And thus, an additional way to fail has been created for our services.

In [“The Thundering Herd”](#), we discussed the thundering herd and how retries or failovers can rapidly take down an entire system. The problem discussed in this section has somewhat of the opposite flavor, and that is a system struggling to catch back up.

Imagine a system that is searching for photos that match a photo of our favorite pet. In this system, requests come in, they are processed asynchronously, and the results are made available for the person making the request. But what if, by the time the results come back, the person is no longer waiting? What if they have hit *reload* and resubmitted one, or even countless additional requests. With no one waiting for the results, the work done to produce the results is wasted, and worse yet, the time taken to

produce those results has delayed our system responding to actual user requests.

To understand how this happens, imagine that our photo processing system has suffered a failure in its object recognition microservice. Processing requests grinds to a stop, but the inbound requests keep arriving. A little like a jam in an assembly line, even though no work is being processed, new work keeps coming down the conveyor belt. This is obviously problematic; but working quickly, we manage to resolve the problem, and work starts being processed again. But what happens now?

During the time that the system wasn't processing any work, a backlog of work has accrued at the component which failed. If the system is close to its optimal load at steady state, as is desirable for maximal efficiency, the system will have a very hard time processing through this backlog. As long as the backlog exists, new requests are delayed. It's not uncommon in such situations for a short outage, say less than 10 minutes, to cause a multihour increase in the latency of request processing, and corresponding degradation in customer experience.

So how can we build our systems to respond better in the face of such backlogs and latency increases? There are three approaches which can be used independently or together to solve the situation. The first is timing out requests. Every request that enters the system should have a timeout, the time after which the request is considered invalid and failed. When the

request times out, any work associated with that request is aborted. Timeouts can help the system shed work when significantly overloaded. However, it is important to note that timeouts by themselves cannot resolve the problem described above. If the latency of each request is high, but slightly lower than the timeout value, your system will seem very sluggish, but it won't ever shed work to get back to normal.

The second approach is to use autoscaling based on request latency. We are used to seeing autoscaling based on CPU or memory usage, but often it makes even more sense to autoscale based on user-facing metrics like processing latency. If your system can enable autoscaling, scaling based on request latency can help process the backlog that accumulated when it was down. Even simply manually scaling after an outage, while less efficient, can be an effective mitigation.

The final approach is to explicitly prioritize newer requests over older requests when your queues grow too long or latency grows too high. This approach is a form of triage, which sacrifices the experience of some users, who in all likelihood already abandoned that request anyway, to ensure that more recent requests, likely the same users hitting *reload*, have a better experience.

Designing reliable distributed systems means not only designing systems that prevent failures from occurring, but also systems that recover quickly when failures do occur. Users are far more accepting of short outages when

the system recovers quickly than prolonged outages where recovery takes a long time, even after the problem is “fixed.”

The “Second System” Problem

So far we have seen numerous common problems that arise in distributed systems. As you have read through this chapter, you may have recognized several different problems that are present in your current system. Seeing the possibility of failures, you are eager to improve the system, but how can you do it?

Sometimes there are only a few changes needed, and it’s obvious how to make these minor improvements to the existing system—roll them out and be done with it. Unfortunately, more often than not, the problems seem so large and so hard to fix in the existing system that it seems the most efficient solution is to build a new system, from scratch, that replaces the existing system at some date in the future. This approach is attractive for a number of reasons: it’s always easier to build from scratch rather than refactor; it is always more exciting to build something new than it is to refactor an existing solution; and finally, building the new system alongside the old system allows the new system to be built without the pressures of being used in production until it is ready.

The attraction of all of these perceived benefits makes building the “second system” one of the most common failures in distributed systems; but it is this last phrase, “until it is ready,” that turns out to be the curse of the second system. In practice, many second systems never actually become ready. There are many different organizational reasons why this can happen, but the most common are that the second system is forever playing catch-up to the current system and that it never gets the production mileage necessary to replace the original system.

The second system tends to play catch-up precisely because it is not the current system in production. This means that while it is being built, all of the important features, bug fixes, and improvements necessary to run the business land in the original system. Suppose it takes six months to complete the second system. At the moment when it is “complete,” there are six more months of features and fixes that it needs to implement until it matches the capabilities of the original system. Unless you are willing to significantly over-staff the team building the second system, you are always playing catch-up.

The need for over-staffing the development of the second system leads to the other failing, which is the production readiness of the second system. In order for any system to become production ready, it needs mileage on it. No matter how good you think your code is, I guarantee that there are bugs that will only be found once it is released into production. But when bugs are found in the second system, the tendency is to turn it off—after all, the

original system didn't have those bugs. This dramatically reduces the exposure and overall mileage that the second system can obtain toward being truly production ready. Just like the feature debt that accumulates as the second system is built, the production readiness debt accrues, and it is very hard for the second system to catch up.

Given that there are probably design problems or technical debt in your distributed system that you need or want to fix, and the "second system" approach is often doomed to failure, what can you do? The solution lies in the nature of the distributed system itself. Rather than replacing the entire distributed system, focusing on improving individual microservices can make real progress tractable and significantly reduce the costs of running two systems in production at once. Similarly, it makes sense to invest in abstractions that separate the core business logic from code that may need to change as you grow and scale, for example, the storage layer. This separation means that you can iterate your core systems like storage independently from your business logic and even run two different storage layers side by side for evaluation and testing.

Much like many other aspects of our lives, the urge to throw away the old and build something new, while tempting, is ultimately far less successful than adapting and improving our existing systems to meet the new needs of our businesses and our users.

Summary

This chapter is unlike any of the others; instead of discussing how to build, it discusses how *not* to build. Hopefully, seeing the common ways that distributed systems fail helps you find problems in your existing systems and also to build more reliable new systems. Learning from the failures of others prevents you from making these common mistakes in your systems.

Conclusion: A New Beginning?

Every company, regardless of its origins, is becoming a digital company. This transformation requires the delivery of APIs and services to be consumed by mobile applications, devices in the internet of things (IoT), or even autonomous vehicles and systems. The increasing criticality of these systems means that these online systems must be built for redundancy, fault tolerance, and high availability. At the same time, the requirements of business necessitate rapid agility to develop and roll out new software, iterate on existing applications, or experiment with new user interfaces and APIs. The confluence of these requirements has led to an order of magnitude increase in the number of distributed systems that need to be built.

The task of building these systems is still far too difficult. The overall cost of developing, updating, and maintaining such a system is far too high. Likewise, the set of people with the capabilities and skills to build such applications is far too small to address the growing need.

Historically, when these situations presented themselves in software development and technology, new abstraction layers and patterns of software development emerged to make building software faster, easier, and more reliable. This first occurred with the development of the first compilers and programming languages. Later, the development of object-

oriented programming languages and managed code occurred. Likewise, at each of these moments, these technical developments crystallized the distillation of the knowledge and practices of experts into a series of algorithms and patterns that could be applied by a much wider group of practitioners. Technological advancement combined with the establishment of patterns democratized the process of developing software and expanded the set of developers who could build applications on the new platform. This in turn led to the development of more applications and application diversity, which in turn expanded the market for these developers' skills.

Again, we find ourselves at a moment of technological transformation. The need for distributed systems far exceeds our ability to deliver them. Fortunately, the development of technology has produced another set of tools to further expand the pool of developers capable of building these distributed systems. The recent development of containers and container orchestration has brought tools that enable rapid, easier development of distributed systems. With luck, these tools, when combined with the patterns and practices described in this book, can enhance and improve the distributed systems built by current developers, and more importantly, develop a whole new expanded group of developers capable of building these systems.

Patterns like sidecars, ambassadors, sharded services, FaaS, work queues, and more can form the foundation on which modern distributed systems are built. Distributed system developers should no longer be building their

systems from scratch as individuals but rather collaborating together on reusable, shared implementations of canonical patterns that form the basis of all of the systems we collectively deploy. This will enable us to meet the demands of today's reliable, scalable APIs and services and empower a new set of applications and services for the future.

Index

A

- absence of errors problem, [The Absence of Errors Is an Error](#)
- abstraction and encapsulation, microservices, [Serving Patterns](#)
- accessibility of the data, [Aggregating Information](#)
- adapter containers, [Adapters](#), [Adding a Health Monitor](#)
- adapter pattern, [Adapters-Summary](#)
 - versus decorator pattern, [The Decorator Pattern: Request or Response Transformation](#)
 - health monitoring, [Adding a Health Monitor-Hands On: Adding Rich Health Monitoring for MySQL](#)
 - logging, [Logging-Hands On: Normalizing Different Logging Formats with fluentd](#)
 - and merger pattern for workflow systems, [Merger](#)
 - monitoring applications, [Monitoring-Hands On: Using Prometheus for Monitoring](#)
- aggregating information, [Hands On: Using Prometheus for Monitoring, Metrics, Metrics](#), [Aggregating Information-Aggregating Information](#)
- AI inference and serving, [AI Inference and Serving-Summary](#)
 - AI systems, [The Basics of AI Systems-The Basics of AI Systems](#)
 - development with models, [Development with Models](#)
 - distributing a model, [Distributing a Model-Distributing a Model](#)

hosting a model, [Hosting a Model](#)

RAG, [Retrieval-Augmented Generation](#)

testing and deployment of services, [Testing and Deployment-Testing and Deployment](#)

alerting, monitoring and observability patterns, [Monitoring and Observability Basics](#), [Alerting-Alerting on anomalies](#)

algorithmic programming, [Formalization of Algorithmic Programming](#)

ambassador pattern, [Ambassadors-Summary](#)

for experimentation, [Using an Ambassador to Do Experimentation or Request Splitting-Hands On: Implementing 10% Experiments](#)

memcache deployment, [Hands On: Deploying an Ambassador and Memcache for a Sharded Cache-Hands On: Deploying an Ambassador and Memcache for a Sharded Cache](#)

request splitting, [Using an Ambassador to Do Experimentation or Request Splitting-Hands On: Implementing 10% Experiments](#)

service brokering, [Using an Ambassador for Service Brokering](#)

for sharded cache, [Hands On: Deploying an Ambassador and Memcache for a Sharded Cache-Hands On: Deploying an Ambassador and Memcache for a Sharded Cache](#)

sharding a service, [Using an Ambassador to Shard a Service-Hands On: Implementing a Sharded Redis](#)

work queues, [The Source Container Interface-Work Queue API](#)

anomalies, alerting on, [Alerting on anomalies](#)

Apache Storm, [Hands On: Normalizing Different Logging Formats with fluentd](#)

application containers

and adapter container, [Adapters](#)

dealing with reused, [Logging](#)

health monitoring, [Health Checks](#), [Adding a Health Monitor-Hands On: Adding Rich Health Monitoring for MySQL](#)

and sidecar pattern, [Single-Node Patterns](#), [Modular Application Containers-Hands On: Deploying the topz Container](#)

application programming interfaces (APIs), [APIs and RPCs-APIs and RPCs](#)

defining container's API, [Define Each Container's API](#)

dynamic configuration, sidecar pattern, [Dynamic Configuration with Sidecars-Dynamic Configuration with Sidecars](#)

file-based API, [The Worker Container Interface](#)

HTTP RESTful API, [The Decorator Pattern: Request or Response Transformation-Hands On: Adding Request Defaulting Prior to Request Processing](#), [Work Queue API](#), [The Worker Container Interface](#)

metrics API, Prometheus, [Hands On: Using Prometheus for Monitoring](#)

and microservices, [Serving Patterns](#)

pub/sub API, [Publisher/Subscriber Infrastructure](#)

RESTful web API, AI models, [Development with Models](#)

versioning of, [Work Queue API](#)

work queue systems, [Work Queue API-Work Queue API](#)

application protocol, replicated services, [Application-Layer Replicated Services](#)

application-layer replicated services, [Application-Layer Replicated Services](#)

The Art of Computer Programming (Knuth), [Formalization of Algorithmic Programming](#)

asynchronous versus synchronous APIs, [APIs and RPCs](#)

authentication, FaaS, [Hands On: Implementing Two-Factor Authentication-Hands On: Implementing Two-Factor Authentication](#)

autoscaler, work queues, [Dynamic Scaling of the Workers](#)

autoscaling, obsolete work processing solution, [Processing Obsolete Work](#)

availability, relationship to consistency and partition tolerance, [Data Consistency](#)

B

background processing, FaaS, [The Need for Background Processing](#)

backlog

processing obsolete work, [Processing Obsolete Work](#)

work item, [Errors, Priority, and Retry](#)

barrier synchronization, [Join \(or Barrier Synchronization\)](#)

batch computational patterns

AI inference and serving, [AI Inference and Serving-Summary](#)
coordinated batch processing, [Coordinated Batch Processing-Summary](#)
event-based batch processing, [Event-Driven Batch Processing-Summary](#)
failure patterns, [Common Failure Patterns-Summary](#)
monitoring and observability patterns, [Monitoring and Observability Patterns-Summary](#)
work queues, [Work Queue Systems-Summary](#)
breadth of inputs challenge, [Challenges with the Breadth of Inputs-Challenges with the Breadth of Inputs](#)
brokering a service, ambassador pattern, [Using an Ambassador for Service Brokering](#)

C

caches and caching

AI models, [Distributing a Model](#)
local versus global caches, [The Myth of Optional Components](#)
memcache deployment, [Hands On: Deploying an Ambassador and Memcache for a Sharded Cache-Hands On: Deploying an Ambassador and Memcache for a Sharded Cache](#)
replicated services, [Introducing a Caching Layer-Hands On: Deploying nginx and SSL Termination](#)

sharded cache, [Sharded Caching-Hands On: Deploying an Ambassador and Memcache for a Sharded Cache](#), [Hot Sharding Systems](#)

caching web proxy, [Introducing a Caching Layer-Deploying Your Cache](#)
CAP theorem (consistency, availability, partition tolerance), [Data Consistency](#)

circuit breaker solution, [The Thundering Herd](#), [Oops, We “Cleaned Up” Everything](#)

client errors problem, [“Client” and “Expected” Errors](#)

client IP, sharding function, [Selecting a Key](#)

client-server architectures, [A Brief History of Systems Development](#)

client-side considerations

ambassador pattern, [Using an Ambassador to Shard a Service](#), [Hands On: Implementing 10% Experiments](#)

and calling APIs, [APIs and RPCs](#)

thundering herd problem, [The Thundering Herd](#)

Cloud Native Computing Foundation (CNCF), [Hands On: Deploying etcd](#)

collection of queues, [Publisher/Subscriber Infrastructure](#)

compare-and-swap operation, [The Basics of Leader Election](#)

compiler problems, [Challenges with the Breadth of Inputs](#)

concurrency, [Ownership Election](#), [Implementing Locks](#)

concurrent data manipulation handling, [Handling Concurrent Data Manipulation-Handling Concurrent Data Manipulation](#)

ConfigMap, [Dynamic Configuration with Sidecars](#), [The Worker Container Interface](#)

configuration synchronization, sidecar pattern, [Dynamic Configuration with Sidecars](#)-[Dynamic Configuration with Sidecars](#)

consensus algorithm, [The Value of Patterns, Practices, and Components-Shared Components for Easy Reuse](#), [The Basics of Leader Election-Hands On: Deploying etcd](#)

consistency

of data, [Data Consistency](#)-[Data Consistency](#)

relationship to availability and partition tolerance, [Data Consistency](#)

consistent hashing function, [Session Tracked Services](#)

container groups, [Single-Node Patterns](#)-[Single-Node Patterns](#), [The Sidecar Pattern](#)

container images, [Shared Components for Easy Reuse](#), [Documenting Your Containers](#), [Documenting Your Containers](#), [The Worker Container Interface](#)

container orchestration, [Introduction](#), [A Brief History of Systems Development](#), [Conclusion: A New Beginning?](#)

(see also Kubernetes)

containers and containerization, [Introduction](#), [A Brief History of Systems Development](#), [Conclusion: A New Beginning?](#)

adding HTTPS to legacy web service, [An Example Sidecar: Adding HTTPS to a Legacy Service](#)

defining container's API, [Define Each Container's API](#)

documenting containers, [Documenting Your Containers-Documenting Your Containers](#)

and health checks, [Health Checks](#)

impact on distributed systems, [Why I Wrote This Book](#)

leader election, [Determining If You Even Need Leader Election-Determining If You Even Need Leader Election](#)

modularity, designing for, [Modular Application Containers-Hands On: Deploying the topz Container](#), [Ambassadors](#), [Adapters](#)

online resources, [Online Resources](#)

team ownership goals, [Single-Node Patterns](#)

in work queues, [A Generic Work Queue System](#), [The Worker Container Interface-The Worker Container Interface](#)

coordinated batch processing, [Coordinated Batch Processing-Summary](#)

image tagging and processing pipeline, [Hands On: An Image Tagging and Processing Pipeline-Hands On: An Image Tagging and Processing Pipeline](#)

join pattern (barrier synchronization, [Join \(or Barrier Synchronization\)](#))

reduce pattern, [Reduce-Reduce](#)

copier pattern, work queue, [Copier](#)

CoreOS, [Hands On: Deploying etcd](#)

correlation ID, request tracing, [Tracing](#)

counting, coordinated batch processing, [Hands On: Count-Hands On: Count](#)

counts, monitoring data, [Metrics](#)

D

data consistency, [Data Consistency](#)-[Data Consistency](#)

data replication, [Data Consistency](#)

data synchronization, [Relational Integrity](#)

debugging, and microservices-based systems, [Serving Patterns](#)

decorator pattern, FaaS, [The Decorator Pattern: Request or Response Transformation](#)-[Hands On: Adding Request Defaulting Prior to Request Processing](#)

decoupling

event-based pipelines, [Event-Based Pipelines](#)-[Hands On: Implementing a Pipeline for New User Signup](#)

and FaaS, [The Benefits of FaaS](#)-[The Challenges of FaaS](#), [Handling Events](#)

of microservices, [Serving Patterns](#)

deep monitoring, [Hands On: Adding Rich Health Monitoring for MySQL](#)-[Hands On: Adding Rich Health Monitoring for MySQL](#)

delivery semantics, messages, [Delivery Semantics](#)

denial-of-service attacks, [Hands On: Deploying nginx and SSL Termination](#)

dependencies and dependency management, [Shared Components for Easy Reuse](#)

Design Patterns: Elements of Reusable Object-Oriented Programming
(Gamma et al.), [Patterns for Object-Oriented Programming](#)

determinism characteristic, sharding function, [An Examination of Sharding Functions](#)

development with AI models, [Development with Models](#)

dictionary-server service, [Hands On: Creating a Replicated Service in Kubernetes](#)-[Hands On: Creating a Replicated Service in Kubernetes](#),
[Hands On: Deploying the Caching Layer](#)-[Hands On: Deploying the Caching Layer](#)

distributed consensus algorithm, [The Value of Patterns, Practices, and Components](#)-[Shared Components for Easy Reuse](#), [The Basics of Leader Election](#)-[Hands On: Deploying etcd](#)

distributed lock server (etcd) implementations, [The Basics of Leader Election](#), [Hands On: Deploying etcd](#), [Hands On: Implementing Locks in etcd](#)-[Hands On: Implementing Locks in etcd](#), [Hands On: Implementing Leases in etcd](#)

distributed ownership, [Ownership Election](#)

(see also ownership election)

distributed systems, [Introduction-Summary](#)

APIs, [APIs and RPCs](#)-[APIs and RPCs](#)

challenges in meeting demands of, [Conclusion: A New Beginning?](#)-
[Conclusion: A New Beginning?](#)

container orchestration, [Introduction](#), [A Brief History of Systems Development](#), [Orchestration and Kubernetes](#), [Conclusion: A New](#)

Beginning?

current state of, [The World of Distributed Systems Today](#).

data consistency, [Data Consistency-Data Consistency](#).

delivery semantics, [Delivery Semantics](#)

health checks, [Health Checks](#)

historical development, [A Brief History of Systems Development](#)

idempotency, [Idempotency, Errors, Priority, and Retry](#).

latency, [Latency](#).

pattern history, [A Brief History of Patterns in Software Development-
The Rise of Open Source Software](#)

percentiles, [Percentiles](#)

relational integrity, [Relational Integrity](#).

reliability, [A Brief History of Systems Development](#), [Reliability](#),
[Relational Integrity](#).

value of patterns, practices, and components, [The Value of Patterns,
Practices, and Components-Shared Components for Easy Reuse](#)

Dockerfiles, [Documenting Your Containers](#), [Hands On: Implementing a
Video Thumbnailer](#)

document search, scatter/gather pattern, [Hands On: Distributed
Document Search-Hands On: Sharded Document Search](#)

documenting container, sidecar pattern, [Documenting Your Containers-
Documenting Your Containers](#)

downsampling, metrics, [Aggregating Information](#)

dynamic configuration, sidecar pattern, [Dynamic Configuration with Sidecars](#)-[Dynamic Configuration with Sidecars](#)

E

embarrassingly parallel problem, scatter/gather pattern, [Scatter/Gather with Root Distribution](#)

encapsulation and abstraction, microservices, [Serving Patterns](#)

ENV directive, [Documenting Your Containers](#)

environment variables, parameterized container, [Documenting Your Containers](#)

error handling, work queue system, [Errors, Priority, and Retry](#)

etcd (distributed lock server) implementations, [The Basics of Leader Election](#), [Hands On: Deploying etcd](#), [Hands On: Implementing Locks in etcd](#)-[Hands On: Implementing Locks in etcd](#), [Hands On: Implementing Leases in etcd](#)

event-based pipelines, [Event-Based Pipelines](#)-[Hands On: Implementing a Pipeline for New User Signup](#)

event-driven batch processing (see workflow systems)

event-driven long-running processing (see function-as-a-service)

events versus requests, [Handling Events](#)

eventual data consistency, [Data Consistency](#)-[Data Consistency](#)

“expected” errors problem, [“Client” and “Expected” Errors](#)

experimentation, ambassador pattern, [Using an Ambassador to Do Experimentation or Request Splitting](#)-[Hands On: Implementing 10%](#)

Experiments

exponential backoff, [Errors, Priority, and Retry](#), [The Thundering Herd](#)
EXPOSE directive, [Documenting Your Containers](#)

F

failure patterns, [Common Failure Patterns-Summary](#)

absence of errors problem, [The Absence of Errors Is an Error](#)

breadth of inputs challenges, [Challenges with the Breadth of Inputs-Challenges with the Breadth of Inputs](#)

client errors problem, [“Client” and “Expected” Errors](#)

“expected” errors problem, [“Client” and “Expected” Errors](#)

obsolete work, processing, [Processing Obsolete Work-Processing Obsolete Work](#)

optional components myth, [The Myth of Optional Components](#)

runaway deletion of system error, [Oops, We “Cleaned Up”](#)

[Everything-Oops, We “Cleaned Up” Everything](#)

“second system” problem, [The “Second System” Problem-The “Second System” Problem](#)

thundering herd, [The Thundering Herd-The Thundering Herd](#)

versioning errors, [Versioning Errors](#)

ffmpeg utility, [Hands On: Implementing a Video Thumbnailer](#)

file-based API, worker container, [The Worker Container Interface](#)

filter pattern, work queue, [Filter](#)

fine-tuning process, AI models, [The Basics of AI Systems](#)

fluentd logging agent, [Hands On: Normalizing Different Logging Formats with fluentd](#)-[Hands On: Normalizing Different Logging Formats with fluentd](#)

frameworks, AI model, [Distributing a Model](#)

function-as-a-service (FaaS), [Functions and Event-Driven Processing-Summary](#).

background processing, need for, [The Need for Background Processing](#)

benefits of, [The Benefits of FaaS](#)

challenges of, [The Challenges of FaaS](#)

costs of sustained request-based processing, [The Costs of Sustained Request-Based Processing](#)

decorator pattern, [The Decorator Pattern: Request or Response Transformation](#)-[Hands On: Adding Request Defaulting Prior to Request Processing](#)

event-based pipelines, [Event-Based Pipelines](#)-[Hands On: Implementing a Pipeline for New User Signup](#)

handling events, [Handling Events](#)-[Hands On: Implementing Two-Factor Authentication](#)

holding data in memory, need for, [The Need to Hold Data in Memory](#).

patterns for, [Patterns for FaaS](#)-[Hands On: Implementing a Pipeline for New User Signup](#)

two-factor authentication, [Hands On: Implementing Two-Factor Authentication](#)-[Hands On: Implementing Two-Factor Authentication](#)

“fuzzed” (randomized) data, testing for breadth of inputs problem,

[Challenges with the Breadth of Inputs](#)

G

Gamma, Erich et al., [Patterns for Object-Oriented Programming](#)

garbage collection, and runaway deletion problem, [Oops, We “Cleaned](#)

[Up” Everything-Oops, We “Cleaned Up” Everything](#)

H

hashing function, [Session Tracked Services, An Examination of](#)

[Sharding Functions-Hands On: Building a Consistent HTTP Sharding](#)

[Proxy](#)

health monitoring, [Health Checks, Adding a Health Monitor-Hands On:](#)

[Adding Rich Health Monitoring for MySQL](#)

Helm package manager, [Hands On: Deploying etcd, Hands On:](#)

[Deploying Kafka-Hands On: Deploying Kafka](#)

histograms, [Histogram, Metrics, Basic Request Monitoring](#)

hit rate, cache, [Deploying Your Cache, The Role of the Cache in System](#)

[Performance](#)

horizontally scalable systems, [Stateless Services](#)

hosting an AI model, [Hosting a Model](#)

hot sharding systems, [Hot Sharding Systems](#)

Hugging Face, [Distributing a Model](#)

Hypertext Transfer Protocol (HTTP)

adding HTTPS to legacy web service with sidecar, [An Example Sidecar: Adding HTTPS to a Legacy Service](#)

requests

decorator pattern, [The Decorator Pattern: Request or Response Transformation](#)

and reliability metric, [Reliability](#)

sharding proxy, [Hands On: Building a Consistent HTTP Sharding Proxy](#)

response codes, [Basic Request Monitoring](#)

RESTful API, [The Decorator Pattern: Request or Response Transformation](#)-[Hands On: Adding Request Defaulting Prior to Request Processing](#), [Work Queue API](#), [The Worker Container Interface](#)

topz interface, [Modular Application Containers](#)

I

idempotency, [Idempotency](#), [Errors](#), [Priority](#), [and Retry](#)

image tagging and processing pipeline, [Hands On: An Image Tagging and Processing Pipeline](#)-[Hands On: An Image Tagging and Processing Pipeline](#)

index

log, [Aggregating Information](#)

scatter/gather pattern, [Hands On: Distributed Document Search](#)

inference, AI models, [The Basics of AI Systems](#), [Hosting a Model](#),
[Development with Models](#)
integrity, relational, [Relational Integrity](#)
interactive inference, AI models, [Hosting a Model](#)
interarrival time, work queues, [Dynamic Scaling of the Workers](#)
IP-based session tracking, [Session Tracked Services](#)
isolation boundary, sharding, [Sharded Services](#)

J

jitter, using to spread client load, [The Thundering Herd](#)
Job objects, [The Shared Work Queue Infrastructure](#), [Dynamic Scaling of the Workers](#)
join pattern, [Join \(or Barrier Synchronization\)](#)

K

Kafka deployment, workflow systems, [Hands On: Deploying Kafka](#)-
[Hands On: Deploying Kafka](#)
KEDA (Kubernetes Event-Driven Autoscaling), [Dynamic Scaling of the Workers](#)
key, sharding function, [Selecting a Key-Selecting a Key](#)
key-value stores, [The Basics of Leader Election](#), [Implementing Locks](#)-
[Implementing Locks](#), [Implementing Ownership](#)-[Hands On: Implementing Leases in etcd](#)
Knuth, Donald, [Formalization of Algorithmic Programming](#)

Kubeless FaaS framework, [The Decorator Pattern: Request or Response Transformation](#)

Kubernetes, [Orchestration and Kubernetes](#)

ConfigMap, [Dynamic Configuration with Sidecars](#), [The Worker Container Interface](#)

creating replicated service, [Hands On: Creating a Replicated Service in Kubernetes](#)-[Hands On: Creating a Replicated Service in Kubernetes](#)

etcd deployment with, [Hands On: Deploying etcd](#)

grouping logs across containers, [Aggregating Information](#)

Kafka deployment as container, [Hands On: Deploying Kafka](#)-[Hands On: Deploying Kafka](#)

KEDA project, [Dynamic Scaling of the Workers](#)

Kubeless FaaS framework, [The Decorator Pattern: Request or Response Transformation](#)

memcache deployment, [Hands On: Deploying an Ambassador and Memcache for a Sharded Cache](#)-[Hands On: Deploying an Ambassador and Memcache for a Sharded Cache](#)

pod (container group), [Single-Node Patterns](#), [The Sidecar Pattern](#)

Redis service sharded deployment, [Hands On: Implementing a Sharded Redis](#)-[Hands On: Implementing a Sharded Redis](#)

running FaaS on, [The Costs of Sustained Request-Based Processing](#)

shared work queue infrastructure, [The Shared Work Queue Infrastructure](#)

shell scripts as health checks with adapter, [Adding a Health Monitor](#)
Kubernetes Event-Driven Autoscaling (KEDA), [Dynamic Scaling of the
Workers](#)

L

LABEL directive, [Documenting Your Containers](#)

large language models (LLMs), [The Basics of AI Systems](#), [Hosting a
Model](#)

latency, [Latency](#)

AI models, [Hosting a Model](#)

backlog, processing obsolete work, [Processing Obsolete Work](#)

caching, [The Role of the Cache in System Performance](#)

join pattern for workflow systems, [Join \(or Barrier Synchronization\)](#)

monitoring server requests, [Basic Request Monitoring](#)

and percentiles, [Percentiles](#)

tracking in work queues, [Dynamic Scaling of the Workers](#)

leader election

concurrent data manipulation, [Handling Concurrent Data](#)

[Manipulation-Handling Concurrent Data Manipulation](#)

consensus algorithm tools, [The Basics of Leader Election-Hands On:](#)

[Deploying etcd](#)

determining need for, [Determining If You Even Need Leader](#)

[Election-Determining If You Even Need Leader Election](#)

etcd implementations, [The Basics of Leader Election](#), [Hands On: Deploying etcd](#), [Hands On: Implementing Locks in etcd](#)-[Hands On: Implementing Locks in etcd](#)

locks, [Implementing Locks](#)-[Hands On: Implementing Locks in etcd](#)
leaf sharding, scatter/gather pattern, [Scatter/Gather with Leaf Sharding](#)-[Choosing the Right Number of Leaves](#)

leases, implementing in etcd, [Hands On: Implementing Leases in etcd](#)
legacy web service, adding HTTPS to, [An Example Sidecar: Adding HTTPS to a Legacy Service](#)

leveled logging, [Logging](#)

library containers, work queues, [A Generic Work Queue System](#)

liveness check, [Health Checks](#)

LLMs (large language models), [The Basics of AI Systems](#), [Hosting a Model](#)

load-balanced services (see replicated load-balanced services)

load-balancing node, sharded services, [Sharded Services](#)

locks, distributed, [Ownership Election](#)

(see also mutual exclusion locks)

logging

adapter pattern, [Logging](#)-[Hands On: Normalizing Different Logging Formats with fluentd](#)

aggregating across processes, [Aggregating Information](#)-[Aggregating Information](#)

monitoring and observability patterns, [Monitoring and Observability Basics](#), [Logging-Logging](#)

logging libraries, [Logging-Logging](#)

long-running server applications versus batch processing, [Batch Computational Patterns](#)

M

MapReduce pattern, [Batch Computational Patterns](#), [Coordinated Batch Processing](#), [Reduce](#)

memcache deployment, ambassador pattern, [Hands On: Deploying an Ambassador and Memcache for a Sharded Cache](#)-[Hands On: Deploying an Ambassador and Memcache for a Sharded Cache](#)

memory

caching issues with usage, [The Myth of Optional Components](#)

need to holding data in memory (FaaS), [The Need to Hold Data in Memory](#)

merger pattern, [Merger](#), [Join \(or Barrier Synchronization\)](#)

message delivery semantics, [Delivery Semantics](#)

metrics

monitoring and observability, [Monitoring and Observability Basics](#), [Metrics-Metrics](#), [Alerting on anomalies](#), [Aggregating Information](#)

Prometheus monitoring, [Hands On: Using Prometheus for Monitoring](#), [Basic Request Monitoring](#)

reliability as key in distributed systems, [Reliability](#)

microcontainers, [Define Each Container's API](#)

microservices, [Serving Patterns-Serving Patterns](#)

decoupling of, [Serving Patterns](#)

versus event-based pipelines, [Event-Based Pipelines](#)

experimentation as separate service, [Hands On: Implementing 10% Experiments](#)

focus on improving to catch up with needed changes, [The "Second System" Problem](#)

tracing requests through multiple, [Tracing](#)

miss rate, sharding function, [Consistent Hashing Functions](#)

model, AI, [The Basics of AI Systems](#)

modularity, designing patterns with

adapters, [Adapters](#)

ambassadors, [Ambassadors](#)

sidecars, [Modular Application Containers-Documenting Your Containers](#)

modulo operator (%), hash function, [An Examination of Sharding Functions](#)

monitoring and observability patterns, [Monitoring and Observability. Patterns-Summary.](#)

adapter pattern, [Monitoring-Hands On: Using Prometheus for Monitoring](#), [Adding a Health Monitor-Hands On: Adding Rich Health Monitoring for MySQL](#)

aggregating information, [Aggregating Information-Aggregating Information](#)

alerting, [Monitoring and Observability Basics](#), [Alerting-Alerting on anomalies](#)

health of application containers, [Adding a Health Monitor-Hands On: Adding Rich Health Monitoring for MySQL](#)

logging, [Monitoring and Observability Basics](#), [Logging-Logging](#)

metrics, [Monitoring and Observability Basics](#), [Metrics-Metrics](#), [Aggregating Information](#)

request monitoring, [Basic Request Monitoring-Advanced Request Monitoring](#)

tracing, [Tracing](#)

monitoring container, adapter pattern, [Monitoring](#)

monolithic systems versus microservices, [Serving Patterns](#)

multinode serving patterns, [Serving Patterns](#)

(see also serving patterns)

multiworker pattern, [The Multiworker Pattern](#)

mutual exclusion locks (mutexes), [Ownership Election](#)

concurrent data manipulation handling, [Handling Concurrent Data Manipulation-Handling Concurrent Data Manipulation](#)

implementing, [The Basics of Leader Election](#), [Hands On: Deploying etcd](#), [Hands On: Implementing Leases in etcd](#)

renewable locks, [Implementing Ownership-Hands On: Implementing Leases in etcd](#)

MySQL database

rich health monitoring, [Hands On: Adding Rich Health Monitoring for MySQL](#)-[Hands On: Adding Rich Health Monitoring for MySQL](#)
service brokering with ambassador pattern, [Using an Ambassador for Service Brokering](#)

N

network address translation (NAT), [Session Tracked Services](#)

Network File System (NFS) share, [Hands On: Implementing a Video Thumbnailer](#)

neural network models, [The Basics of AI Systems](#)

new-user signup, [Hands On: Implementing a Pipeline for New User Signup](#)-[Hands On: Implementing a Pipeline for New User Signup](#),
[Hands On: Building an Event-Driven Flow for New User Signup](#)-[Hands On: Building an Event-Driven Flow for New User Signup](#)

nginx application, SSL termination with, [SSL Termination](#), [Hands On: Deploying nginx and SSL Termination](#)-[Hands On: Deploying nginx and SSL Termination](#)

nginx sidecar container, [An Example Sidecar: Adding HTTPS to a Legacy Service](#)

nginx web server, [Hands On: Implementing 10% Experiments](#)

NoSQL versus SQL data stores, [Relational Integrity](#).

O

object-oriented programming, patterns for, [Patterns for Object-Oriented Programming](#)

obsolete work, processing, [Processing Obsolete Work-Processing Obsolete Work](#)

Open Containers Initiative (OCI), [Documenting Your Containers](#)

Open Neural Network eXchange (ONNX), [Distributing a Model](#)

open source software, [The Rise of Open Source Software](#), [Distributing a Model](#)

OpenTelemetry, [Tracing](#)

optional components myth, [The Myth of Optional Components](#)

overloading of requests (thundering herd), [The Thundering Herd-The Thundering Herd](#)

ownership election, [Ownership Election-Summary](#)

concurrent data manipulation, [Handling Concurrent Data Manipulation-Handling Concurrent Data Manipulation](#)

etcd implementations, [Hands On: Implementing Leases in etcd](#)

leader election (see leader election)

renewable locks, [Implementing Ownership-Hands On: Implementing Leases in etcd](#)

P

PaaS (platform-as-a-service), sidecar pattern, [Building a Simple PaaS with Sidecars-Building a Simple PaaS with Sidecars](#)

parallel processing

logging duplications, [Logging](#)

scatter/gather pattern, [Scatter/Gather](#), [Choosing the Right Number of Leaves](#)

work queue dynamic scaling, [Dynamic Scaling of the Workers](#)

parameterized sidecar containers, [Parameterized Containers](#)

partition tolerance, relationship to consistency and availability, [Data Consistency](#)

patterns, [The Rise of Open Source Software](#)

batch computational patterns (see batch computational patterns)

history in software development, [A Brief History of Patterns in Software Development-The Rise of Open Source Software](#)

and microservices, [Serving Patterns](#)

monitoring and observability, [Monitoring and Observability Patterns-Summary](#)

serving patterns (see serving patterns)

shared components for reuse, [Shared Components for Easy Reuse](#)

as shared language, [A Shared Language for Discussing Our Practice](#)

single-node patterns (see single-node patterns)

value of, [The Value of Patterns, Practices, and Components-Shared Components for Easy Reuse](#)

percentiles, [Percentiles](#)

pipelines

event-based, [Event-Based Pipelines-Hands On: Implementing a Pipeline for New User Signup](#)

image tagging and processing, [Hands On: An Image Tagging and Processing Pipeline](#)-[Hands On: An Image Tagging and Processing Pipeline](#)

platform-as-a-service (PaaS), sidecar pattern, [Building a Simple PaaS with Sidecars](#)-[Building a Simple PaaS with Sidecars](#)

pod (container group), [Single-Node Patterns](#), [The Sidecar Pattern](#)

poison requests, isolation boundary to protect from, [Sharded Services](#)

poison work solution, [Errors, Priority, and Retry](#).

pretrained models, AI, [Hosting a Model](#)

prioritizing newer requests over older, [Processing Obsolete Work](#)

process-ID (PID) namespace, sidecar container, [Modular Application Containers](#)

Prometheus monitoring aggregator, [Hands On: Using Prometheus for Monitoring](#), [Metrics](#), [Metrics](#), [Basic Request Monitoring](#)

prompts, AI, [The Basics of AI Systems](#)

publisher/subscriber API, [Publisher/Subscriber Infrastructure](#)

publisher/subscriber infrastructure, [Publisher/Subscriber Infrastructure](#)-[Hands On: Deploying Kafka](#)

Python, as language for AI models, [Distributing a Model](#)

R

RAG (Retrieval-Augmented Generation), [Retrieval-Augmented Generation](#)

rate limiting, [Rate Limiting and Denial-of-Service Defense](#)

rate of requests, monitoring, [Basic Request Monitoring](#)

readiness probes for load balancing, [Readiness Probes for Load Balancing](#)

Redis, [Hands On: Implementing a Sharded Redis](#), [Hands On: Implementing a Sharded Redis](#)-[Hands On: Implementing a Sharded Redis](#), [Hands On: Using Prometheus for Monitoring](#)-[Hands On: Using Prometheus for Monitoring](#), [Hands On: Normalizing Different Logging Formats with fluentd](#)

reduce patterns, [Batch Computational Patterns](#), [Coordinated Batch Processing](#), [Reduce-Reduce](#), [Sum](#)

relational integrity, [Relational Integrity](#)

reliability

- of distributed systems, [A Brief History of Systems Development](#), [Reliability](#), [Relational Integrity](#)
- microservices, [Serving Patterns](#)
- monitoring and observability as important for, [Monitoring and Observability Patterns](#)
- scaling of scatter/gather pattern for, [Scaling Scatter/Gather for Reliability and Scale](#)

remote procedure calls (RPCs), [APIs and RPCs](#)

renewable locks, ownership election, [Implementing Ownership](#)-[Hands On: Implementing Leases in etcd](#)

replicated load-balanced services, [Replicated Load-Balanced Services](#)-[Hands On: Deploying nginx and SSL Termination](#)

application protocol, [Application-Layer Replicated Services](#)
application-layer replicated services, [Application-Layer Replicated Services](#)
caching layer deployment and expansion, [Introducing a Caching Layer-Hands On: Deploying nginx and SSL Termination](#)
creating, [Hands On: Creating a Replicated Service in Kubernetes-Hands On: Creating a Replicated Service in Kubernetes](#)
session tracked services, [Session Tracked Services-Session Tracked Services](#)
versus sharded services, [Sharded Services](#)
stateless services, [Stateless Services-Hands On: Creating a Replicated Service in Kubernetes](#)
replicated sharded cache, [Replicated Sharded Caches](#)
request-based processing, FaaS, [The Costs of Sustained Request-Based Processing](#), [Hands On: Adding Request Defaulting Prior to Request Processing](#)
requests
decorator pattern, [The Decorator Pattern: Request or Response Transformation](#)
versus events, [Handling Events](#)
monitoring, [Basic Request Monitoring-Tracing](#)
and reliability metric, [Reliability](#)
sharding proxy, [Hands On: Building a Consistent HTTP Sharding Proxy](#)

splitting, [Using an Ambassador to Do Experimentation or Request Splitting-Hands On: Implementing 10% Experiments](#)

resource isolation, [Single-Node Patterns](#)

resource version, distributed locks, [Implementing Locks](#)

RESTful web API, AI models, [Development with Models](#)

Retrieval-Augmented Generation (RAG), [Retrieval-Augmented Generation](#)

retry queue to handle backlogs, [Errors, Priority, and Retry](#)

reusability, [Introduction](#), [Shared Components for Easy Reuse](#), [Single-Node Patterns](#)

(see also single-node patterns)

multiworker pattern, [The Multiworker Pattern](#)

sidecar pattern, [Modular Application Containers-Hands On: Deploying the topz Container](#), [Designing Sidecars for Modularity and Reusability-Documenting Your Containers](#)

root (load-balancing node), sharded services, [Sharded Services](#)

root distribution, scatter/gather pattern, [Scatter/Gather with Root Distribution-Hands On: Distributed Document Search](#)

RPCs (remote procedure calls), [APIs and RPCs](#)

runaway deletion of system error, [Oops, We “Cleaned Up” Everything-Oops, We “Cleaned Up” Everything](#)

S

scaling and scalability

autoscaling for obsolete work processing solution, [Processing Obsolete Work](#)

and consistent hashing function, [Session Tracked Services](#)

in decoupling of microservices, [Serving Patterns](#)

dynamic scaling of workers, [Dynamic Scaling of the Workers-Dynamic Scaling of the Workers](#)

with FaaS, [The Costs of Sustained Request-Based Processing](#)

horizontally scalable systems, [Stateless Services](#)

scatter/gather pattern, [Scatter/Gather-Summary](#)

sharded services, [Sharded Services-Summary](#)

stateless replicated services, [Stateless Services-Hands On: Creating a Replicated Service in Kubernetes](#)

team scaling, [Single-Node Patterns](#)

scatter/gather pattern, [Scatter/Gather-Summary](#)

distributed document search, [Hands On: Distributed Document Search-Hands On: Distributed Document Search](#)

leaf sharding, [Scatter/Gather with Leaf Sharding-Choosing the Right Number of Leaves](#)

with root distribution, [Scatter/Gather with Root Distribution-Hands On: Distributed Document Search](#)

scaling for reliability, [Scaling Scatter/Gather for Reliability and Scale](#)

“second system” problem, [The “Second System” Problem-The “Second System” Problem](#)

separation of concerns, [Single-Node Patterns](#), [Ambassadors](#), [Using an Ambassador to Shard a Service](#)

serverless computing, versus FaaS, [Functions and Event-Driven Processing](#)

service broker, [Using an Ambassador for Service Brokering](#)

service brokering, ambassador pattern, [Using an Ambassador for Service Brokering](#)

service discovery, [Using an Ambassador for Service Brokering](#)

service level agreement (SLA), [Stateless Services](#)

service level objectives (SLOs), API, [APIs and RPCs](#), [Basic alerting](#)

serving patterns, [Serving Patterns-Serving Patterns](#)

FaaS, [Functions and Event-Driven Processing-Summary](#).

ownership election, [Ownership Election-Summary](#).

replicated load-balanced services, [Replicated Load-Balanced Services-Hands On: Deploying nginx and SSL Termination](#)

scatter/gather pattern, [Scatter/Gather-Summary](#).

sharded services, [Sharded Services-Summary](#).

session tracked services, [Session Tracked Services-Session Tracked Services](#), [Deploying Your Cache](#)

sessions, and events versus requests, [Handling Events](#)

shard key, [Selecting a Key-Selecting a Key](#).

shard pattern, workflow systems, [Hands On: Building an Event-Driven Flow for New User Signup](#)

shard router service, [Hands On: Deploying an Ambassador and Memcache for a Sharded Cache](#)-[Hands On: Deploying an Ambassador and Memcache for a Sharded Cache](#)

sharded cache, [Sharded Caching](#)-[Hands On: Deploying an Ambassador and Memcache for a Sharded Cache](#), [Hot Sharding Systems](#)

sharded services, [Sharded Services-Summary](#).

ambassador pattern, [Using an Ambassador to Shard a Service](#)-[Hands On: Implementing a Sharded Redis](#)

caching layer, [Sharded Caching](#)-[Hands On: Deploying an Ambassador and Memcache for a Sharded Cache](#), [Hot Sharding Systems](#)

document search, [Hands On: Sharded Document Search](#)

hashing functions, [An Examination of Sharding Functions](#)-[Hands On: Building a Consistent HTTP Sharding Proxy](#).

leaf sharding, scatter/gather pattern, [Scatter/Gather with Leaf Sharding-Choosing the Right Number of Leaves](#)

versus replicated services, [Sharded Services](#)

replicated serving, [Sharded Replicated Serving](#)

sharder pattern, workflow systems, [Sharder-Sharder](#)

sharding ambassador proxy, [Using an Ambassador to Shard a Service](#)

sharding functions, [Sharder-Sharder](#)

sharding proxy, HTTP requests, [Hands On: Building a Consistent HTTP Sharding Proxy](#).

shared infrastructure, work queues, [The Shared Work Queue Infrastructure](#)

sidecar pattern, [A Shared Language for Discussing Our Practice](#), [The Sidecar Pattern-Summary](#).

adding HTTPS to a legacy service, [An Example Sidecar: Adding HTTPS to a Legacy Service](#)

cache deployment with, [Deploying Your Cache](#)

designing for modularity and reusability, [Modular Application Containers-Documenting Your Containers](#)

documenting container, [Documenting Your Containers-Documenting Your Containers](#)

dynamic configuration with, [Dynamic Configuration with Sidecars-Dynamic Configuration with Sidecars](#)

PaaS, building with sidecar, [Building a Simple PaaS with Sidecars-Building a Simple PaaS with Sidecars](#)

single-node patterns, [Single-Node Patterns-Single-Node Patterns](#)

adapters, [Adapters-Summary](#).

ambassadors, [Ambassadors-Summary](#).

sidecars, [The Sidecar Pattern-Summary](#).

singleton pattern, ownership election, [Determining If You Even Need Leader Election-Determining If You Even Need Leader Election](#)

SLA (service level agreement), [Stateless Services](#)

SLOs (service level objectives), API, [APIs and RPCs](#), [Basic alerting](#)

slow-query logging, adding to Redis, [Hands On: Normalizing Different Logging Formats with fluentd](#)

small language models (SLMs), [Hosting a Model](#)

source container interface, work queues, [The Source Container Interface](#)

splitter pattern, work queue, [Splitter](#)

SQL injection attacks, [Challenges with the Breadth of Inputs](#)

SQL versus NoSQL data stores, [Relational Integrity](#)

SSL termination, caching layer for, [SSL Termination-Hands On: Deploying nginx and SSL Termination](#)

stateful services (see sharded services)

stateless services, [Using an Ambassador to Shard a Service](#), [Stateless Services-Hands On: Creating a Replicated Service in Kubernetes](#), [Sharded Services](#)

(see also replicated load-balanced services)

static alerting, [Alerting on anomalies](#)

stdout, adapter container's redirect of logs to, [Logging](#)

“straggler” problem, scatter/gather pattern, [Choosing the Right Number of Leaves](#)

strong data consistency, [Data Consistency-Data Consistency](#)

sums, coordinated batch processing, [Sum](#)

synchronous versus asynchronous APIs, [APIs and RPCs](#)

synthetic request to test system, [“Client” and “Expected” Errors](#)

system-generated request to test system, [“Client” and “Expected” Errors](#)

systems development, history of, [A Brief History of Systems Development](#)

T

teams

ownership and containerization goals, [Single-Node Patterns](#)

reliable contract for different services in microservices, [Serving Patterns](#)

scaling of, [Single-Node Patterns](#)

tee-d service, [Using an Ambassador to Do Experimentation or Request Splitting](#)

TensorFlow, [Distributing a Model](#)

testing and deployment of AI services, [Testing and Deployment-Testing and Deployment](#)

testing for breadth of inputs problem, [Challenges with the Breadth of Inputs-Challenges with the Breadth of Inputs](#)

three-nines service, [Stateless Services](#)

throttle module (Varnish), [Rate Limiting and Denial-of-Service Defense](#)

throttling, to prevent runaway deletion, [Oops, We “Cleaned Up” Everything](#)

thundering herd, failure pattern, [The Thundering Herd-The Thundering Herd](#)

time series data monitoring, [Metrics](#)

time-to-live (TTL) functionality of key-value store, [Implementing Locks-Implementing Locks](#), [Implementing Ownership-Hands On: Implementing Leases in etcd](#)

timing out requests, obsolete work processing solution, [Processing Obsolete Work](#)

topz sidecar container, [Modular Application Containers-Hands On: Deploying the topz Container](#)

tracing, monitoring and observability patterns, [Monitoring and Observability Basics](#), [Tracing](#)

traffic overload, failure pattern, [The Thundering Herd-The Thundering Herd](#)

traffic reduction problem, [The Absence of Errors Is an Error](#)

training data, [The Basics of AI Systems](#)

TTL (time-to-live) functionality of key-value store, [Implementing Locks-Implementing Locks](#), [Implementing Ownership-Hands On: Implementing Leases in etcd](#)

twemproxy, [Ambassadors](#)

two-factor authentication, [Hands On: Implementing Two-Factor Authentication-Hands On: Implementing Two-Factor Authentication](#)

U

uniformity characteristic, sharding function, [An Examination of Sharding Functions](#)

Unix signals

SIGHUP, [Dynamic Configuration with Sidecars](#)
SIGKILL, [Dynamic Configuration with Sidecars](#)
user feedback, AI testing, [Testing and Deployment](#)

V

values, monitoring data, [Metrics](#)
Varnish (HTTP reverse proxy), [Expanding the Caching Layer-SSL Termination](#)
versioning errors, [Versioning Errors](#)
versioning of APIs, [Work Queue API](#)
video thumbnailer implementation, [Hands On: Implementing a Video Thumbnailer-Hands On: Implementing a Video Thumbnailer](#)

W

work items, [The Source Container Interface](#), [Work Stealing](#)
work queue systems, [Work Queue Systems-Summary](#)
API (ambassador), [Work Queue API-Work Queue API](#)
building event-driven flow, [Hands On: Building an Event-Driven Flow for New User Signup-Hands On: Building an Event-Driven Flow for New User Signup](#)
dynamic scaling of workers, [Dynamic Scaling of the Workers-Dynamic Scaling of the Workers](#)
multiworker pattern, [The Multiworker Pattern](#)
shared infrastructure, [The Shared Work Queue Infrastructure](#)

source container interface, [The Source Container Interface](#)

video thumbnailer implementation, [Hands On: Implementing a Video Thumbnailer](#)-[Hands On: Implementing a Video Thumbnailer](#)

and work stealing technique, [Work Stealing](#)

worker container interface, [The Worker Container Interface](#)-[The Worker Container Interface](#)

work stealing, work queues, [Work Stealing](#)

worker container interface, [The Worker Container Interface](#)-[The Worker Container Interface](#)

workflow systems, [Event-Driven Batch Processing](#)-[Summary](#)

building event-driven flow, [Hands On: Building an Event-Driven Flow for New User Signup](#)-[Hands On: Building an Event-Driven Flow for New User Signup](#)

copier pattern, [Copier](#)

filter pattern, [Filter](#)

merger pattern, [Merger](#)

publisher/subscriber infrastructure, [Publisher/Subscriber Infrastructure](#)-[Hands On: Deploying Kafka](#)

sharder pattern, [Sharder](#)-[Sharder](#)

splitter pattern, [Splitter](#)

work queue resiliency and performance, [Resiliency and Performance in Work Queues](#)-[Errors, Priority, and Retry](#)

About the Author

Brendan Burns is corporate vice president at Microsoft responsible for Azure management and governance, Azure Arc, Kubernetes on Azure, Linux on Azure, and PowerShell. Prior to Microsoft, he worked at Google in the Google Cloud Platform, where he cofounded the Kubernetes project and helped build APIs like Deployment Manager and Cloud DNS. Before working on cloud, he worked on Google's web-search infrastructure with a focus on low-latency indexing. He has a PhD in computer science from the University of Massachusetts Amherst with a specialty in robotics. He lives in Seattle with his wife, Robin Sanders, their two children, and a cat, Mrs. Paws, who rules over their household with an iron paw.

Colophon

The animal on the cover of *Designing Distributed Systems* is a Java sparrow (*Padda oryzivora*). This bird is loathed in the wild but loved in captivity. Farmers destroy thousands of wild Javas each year to prevent the flocks from devouring their crops. They also trap the birds for food or sell them in the international bird trade. Despite this battle, the species continues to thrive in Java and Bali in Indonesia, as well as Australia, Mexico, and North America.

Its plumage is pearly-gray, turning pinkish on the front and white toward the tail. It has a black head with white cheeks. Its large bill, legs, and eye circles are bright pink. The song of the Java sparrow begins with single notes, like a bell, before developing into a continuous trilling and clucking, mixed with high-pitched and deeper notes.

The main part of their diet is rice, but they also eat small seeds, grasses, insects, and flowering plants. In the wild, these birds will build a nest out of dried grass, normally under the roofs of buildings or in bushes or treetops. The Java will lay a clutch of three or four eggs between February and August, with most eggs laid in April or May.

The Java sparrow is listed as endangered on the International Union for Conservation of Nature (IUCN) Red List of Threatened Species due to the continued loss of its natural habitat, hunting, and trapping. Many of the

animals on O'Reilly covers are endangered; all of them are important to the world.

The cover illustration is by Karen Montgomery, based on a black-and-white engraving from *Lydekker's Royal Natural History*. The series design is by Edie Freedman, Ellie Volckhausen, and Karen Montgomery. The cover fonts are Gilroy Semibold and Guardian Sans. The text font is Adobe Minion Pro; the heading font is Adobe Myriad Condensed; and the code font is Dalton Maag's Ubuntu Mono.